

ENG

TECHNICAL INSTRUCTIONS

for installation, use and maintenance
of hot water boiler and installation of
additional equipment

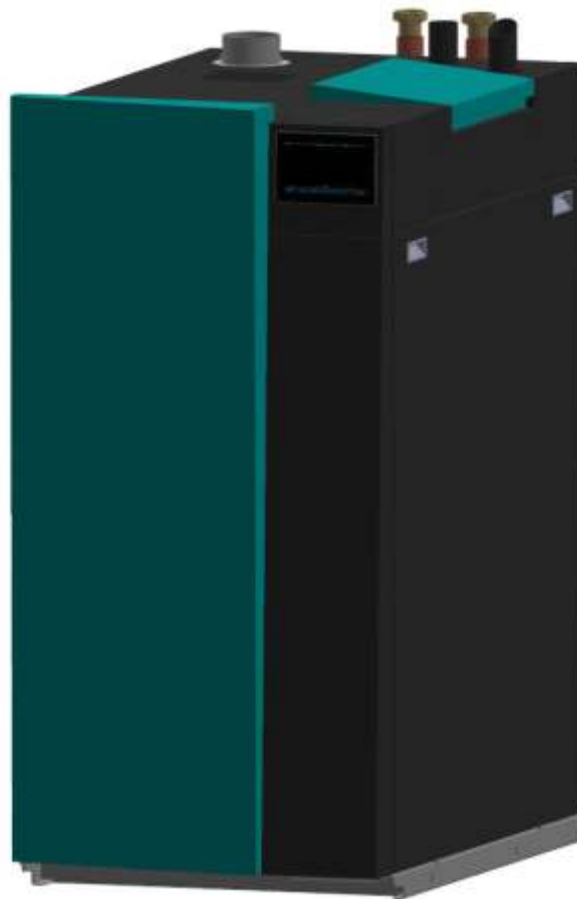

THE FIRST START-UP MUST BE DONE BY AUTHORIZED PERSON,
OTHERWISE PRODUCT WARRANTY IS NOT VALID.

PelTec-Compact

TECHNICAL DATA	03
BASIC ELECTRICAL PARTS AND SENSORS	08
ADDITIONAL EQUIPMENT	08
1.0. INTRODUCTION	09
1.1. BOILER DESCRIPTION	09
1.2. SAFETY PRECAUTIONS	09
1.3. IMPORTANT INFORMATIONS	09
1.4. STATUS OF DELIVERY	10
1.5. SETTING PHOTOCCELL TO THE WORK POSITION	11
1.6. SAFETY ELEMENTS	12
1.7. FUEL	12
2.0. BOILER POSITIONING AND ASSEMBLY	13
2.1. MINIMUM DISTANCE FROM THE ROOM WALLS	13
3.0. CONNECTION TO THE CHIMNEY	15
3.1. INSTALLATION OF BOILERS WITH COMBUSTION AIR SUPPLY FROM OUTSIDE THE BUILDING	15
3.2. INSTALLATION OF BOILERS WITH COMBUSTION AIR SUPPLY FROM INSIDE THE BOILER ROOM	20
3.2.1. OPENING FOR FRESH AIR (FRESH AIR SUPPLY)	20
3.2.2. CONNECTION TO THE CHIMNEY	20
4.0. INSTALLATION	21
4.1. CONNECTION TO CENTRAL HEATING SYSTEM	21
4.1.1. CONNECTION TO CLOSED HEATING SYSTEM	21
4.1.2. SAFETY VALVE - CONNECTING THE DRAIN TO THE SEWER	22
4.1.3. EMPTYING (DRAINAGE) OF THE BOILER / HEATING SYSTEM	22
4.1.4. BOILER HYDRAULIC CROSSOVER OPEN/CLOSED	23
4.1.5. BOILER AIRVENT	23
4.1.6. MANIFOLD / PUMP GROUPS - POSSIBILITY OF INSTALLATION	25
4.2. CONFIGURATION / SCHEME - DESCRIPTION	26
4.2.1. EXAMPLE OF SENSORS AND PUMPS CONNECTIONS (CONFIGURATION 1)	27
4.2.2. CONFIGURATION / SCHEME	28
5.0. INSTALLATION OF PELLET SUPPLY	51
5.1. CONFIGURATION: Mole	51
5.2. CONFIGURATION: Pellet tank	52
5.3. CONFIGURARION: Feeder screw	53
5.4. DELIVERY CONTENT (ADDITIONAL EQUIPMENT FOR CONFIGURATION: Mole)	54
5.5. DELIVERY CONTENT (ADDITIONAL EQUIPMENT FOR CONFIGURATION: Pellet tank)	54
5.6. DELIVERY CONTENT (ADDITIONAL EQUIPMENT FOR CONFIGURATION: Feeder screw)	54
5.6.1. MOUNTING SCREW FEEDER IN THE PELLET STORAGE ROOM AND ELECTRICAL CONNECTION TO THE BOILER	55
6.0. RECOMMENDED ADDITIONAL EQUIPMENT	56
6.1. CONNECTION AND EARTHING OF THE TUBES ON THE VACUUM SUCTION SYSTEM	57
7.0. ELECTRICAL CONNECTIONS	58
7.1. MAIN FUSES / PCB (PRINTED CIRCUIT BOARD) POSITIONS / MODULE CVT	59
7.2. FASTENING OF INPUT/OUTPUT CABLES	63
7.3. CONNECTING ADDITIONAL EQUIPMENT CM2K AND CM-NET TO THE BOILER	64
7.4. ELECTRICAL SCHEME INSTALLATION - PeITec-Compact 12	65
7.5. ELECTRICAL SCHEME INSTALLATION - PeITec-Compact 18/24	79
8.0. OPERATING THE SYSTEM	92
8.1. SAFETY INSTRUCTIONS FOR THE INSTALLATION ROOM	92
8.2. INITIAL STARTUP	92
8.3. FILLING / REFILLING PELLET TANK WITH FUEL	92
8.4. BOILER USE	94
9.0. CLEANING AND MAINTENANCE	97
9.1. CLEANING AND MAINTENANCE - PERIODICALLY	98
9.1.1. EMPTYING THE ASH BOX	98
9.1.2. CLANING OF EXCHANGING SURFACES (ABOVE THE BURNER)	99
9.1.3. CLEANING THE BLADES AND BOX OF THE FAN	100
9.1.4. CLEANING OF EXCHANGING SURFACES (AROUND THE ENTIRE BOILER)	101
9.1.5. CHECKING THE CORRECTNESS OF SAFETY VALVE	102
9.1.6. PHOTOCCELL CLEANING	103
9.2. CLEANING AND MAINTENANCE - IF NEEDED	104
9.2.1. EXTRACTION OF TURBULATORS	104
9.2.2. REPLACEMENT OF THE ELECTRIC HEATER	105
9.2.3. CLEANING THE FLUE BOX	107
9.2.4. CLEANING OF PELLET TANK	108
9.2.5. DRAINING WATER FROM THE BOILER	109
9.2.6. DISASSEMBLY / RETURN TO ITS PLACE ASH EXTRACTION SCREW	109
9.2.7. CHANGING THE BOILER CONTROL UNIT SCREEN BATTERY (CR 1632)	112
9.2.8. MIXING VALVE (3-way mixing valve with actuator - boiler circuit)	113
10.0. CIRCULATION PUMP INSTALLATION	115
CORRECT DISPOSAL OF THIS PRODUCT	120

TECHNICAL DATA

Type: PelTec-Compact		12 kW	18 kW	24 kW	
Useful heat output at rated heat output - P _n	(kW)	12	18	24	
Useful heat output at 30 % of rated heat output - P _p	(kW)	3.6	5.4	7.2	
Useful efficiency at rated heat output (Net calorific value "NCVar")	(%)	94,5	94,5	94,4	
Useful efficiency at 30 % of rated heat output (Net calorific value "NCVar")	(%)	91,7	91,9	92,1	
Useful efficiency at rated heat output (Gross calorific value "GCVar") - η _n	(%)	88,1	88,1	88,0	
Useful eff. at 30 % of rated heat output (Gross calorific value "GCVar") - η _p	(%)	85,5	85,7	85,8	
Heat output range	(kW)	3.6-12	5.4-18	7.2-24	
Boiler class		5			
Required chimney underpressure	(mbar)	0,02			
Water amount in boiler	(l)	61	91	91	
Exhaust gas temperature at nominal heat output	(°C)	80-130			
Exhaust gas temperature at minimal heat output	(°C)	65-120			
Exhaust mass flow at nominal heat output	(g/s)	-	-	-	
Exhaust mass flow at minimal heat output	(g/s)	-	-	-	
Operating (combustion) time	(h)	6			
Setting range for temperature controller	(°C)	65-90			
Minimum return flow temperature	(°C)	> 0°C			
Boiler resistance on water side at nominal output	(mbar)	0,030	0,050	0,100	
Fuel size	(mm)	Ø6 x 50			
Fuel loading chamber capacity	(l)	0,62	0,98	2,59	
Fuel loading chamber dimensions	(mm)	680x210x210	680x260x260	680x260x260	
Combustion chamber volume	(l)	29,2	43,5	43,5	
Combustion chamber type		underpressure			
Pellet tank volume	(l)	47,7			
Ash box volume	(l)	11,5	17,5	17,5	
Auxiliary power requirements at Q _N	(W)	-	-	-	
Auxiliary power requirements at Q _{min}	(W)	-	-	-	
Supply voltage	(V~)	230			
Frequency	(Hz)	50			
Total mass - (boiler with tank and screw feeder)	(kg)	380	440	440	
Max. operating overpressure	(bar)	3,0			
Test pressure	(bar)	6,0			
Max. operating temperature	(°C)	90			
Flue gas tube - external diameter	(mm)	100	130	130	
Boiler connections	Main/return flow (thread) (Rp)	6/4"			
	Emptying (Drainage) (thread) (Rp)	½"			
Heating appliance working		with fan			
Heating appliance working		under non-condensing conditions			
Stoking mode		automatic			
The boiler should be operated with a hot water storage tank of a volume of at least	(l)	240	360	480	
Condensing boiler		no			
Solid fuel cogeneration boiler		no			
Combination boiler		yes			
Preferred fuel		compressed wood in the form of pellets: C1 (EN 303-5:2021+A1:2022); A1 (EN ISO 17225-2)			
Seasonal space heating energy efficiency - η _s	(%)	79	80	81	
Seasonal space heating emissions for preferred fuel *	PM	mg/m ³ (10% O ₂)	20	23	25
	OGC	mg/m ³ (10% O ₂)	3	2	2
	CO	mg/m ³ (10% O ₂)	124	102	80
	NO _x	mg/m ³ (10% O ₂)	142	144	146
Auxiliary electricity consumption	At rated heat output - el _{max}	(kW)	0,081	0,034	0,160
	At 30 % of rated heat output - el _{min}	(kW)	0,065	0,070	0,072
	Of incorporated secondary emission abatement equipm.	(kW)	Not applicable		
	In standby mode - PSB	(kW)	0,004		

*PM = particulate matter, OGC = organic gaseous compounds, CO = carbon monoxide, NO_x = nitrogen oxides

Contact details: Centrometal d.o.o. - Glavna 12, 40306 Macinec, Croatia

Technical data

Boiler dimensions		12 kW	18 kW	24 kW
Width	(A)	680	780	780
Length	(B)	1135	1205	1205
Height	(C)	1430	1430	1430
Dimension (behind the lid is the fresh air inlet tube)	(D)	368	368	368

PeITec-Compact 12-24

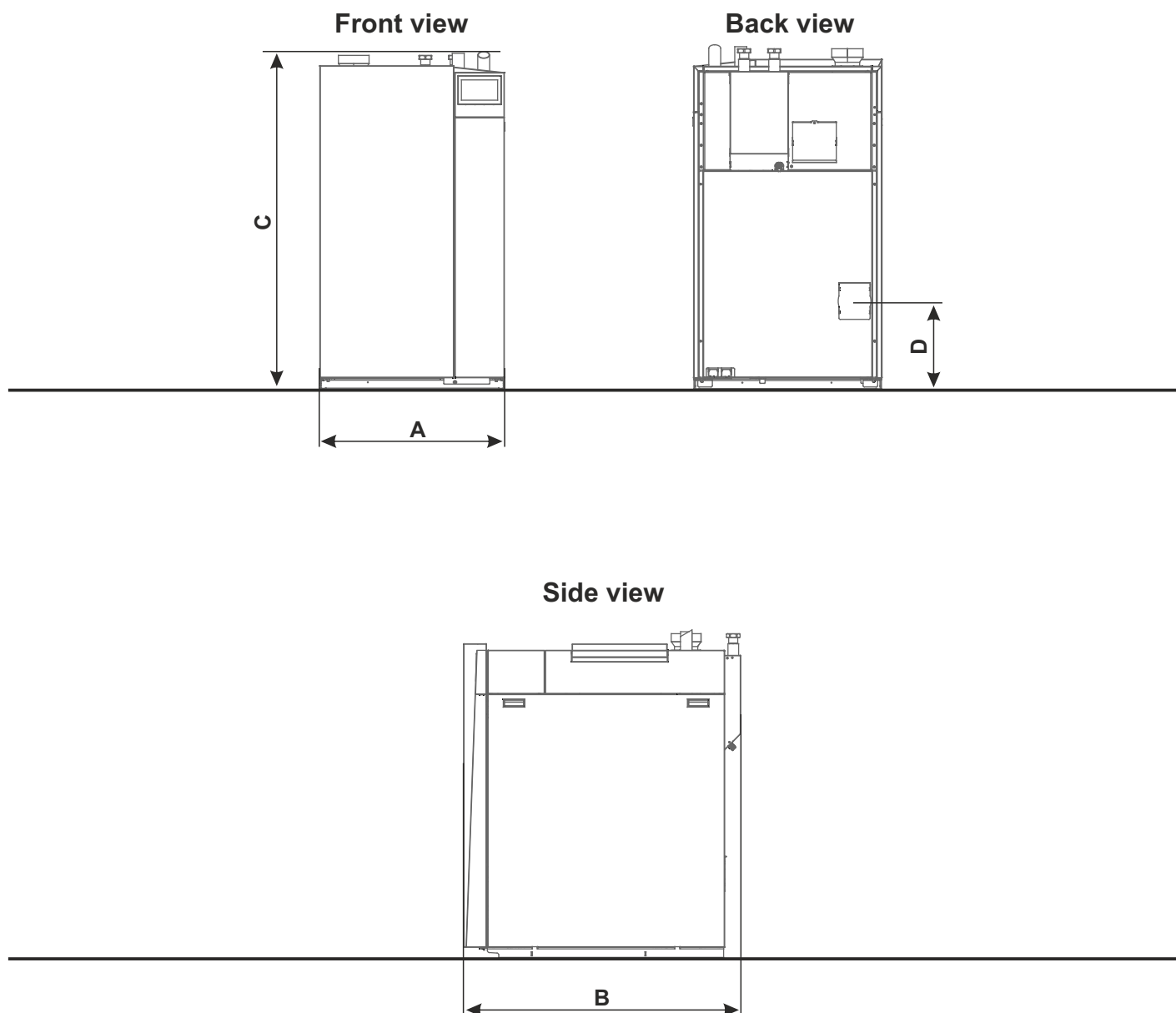

Front view

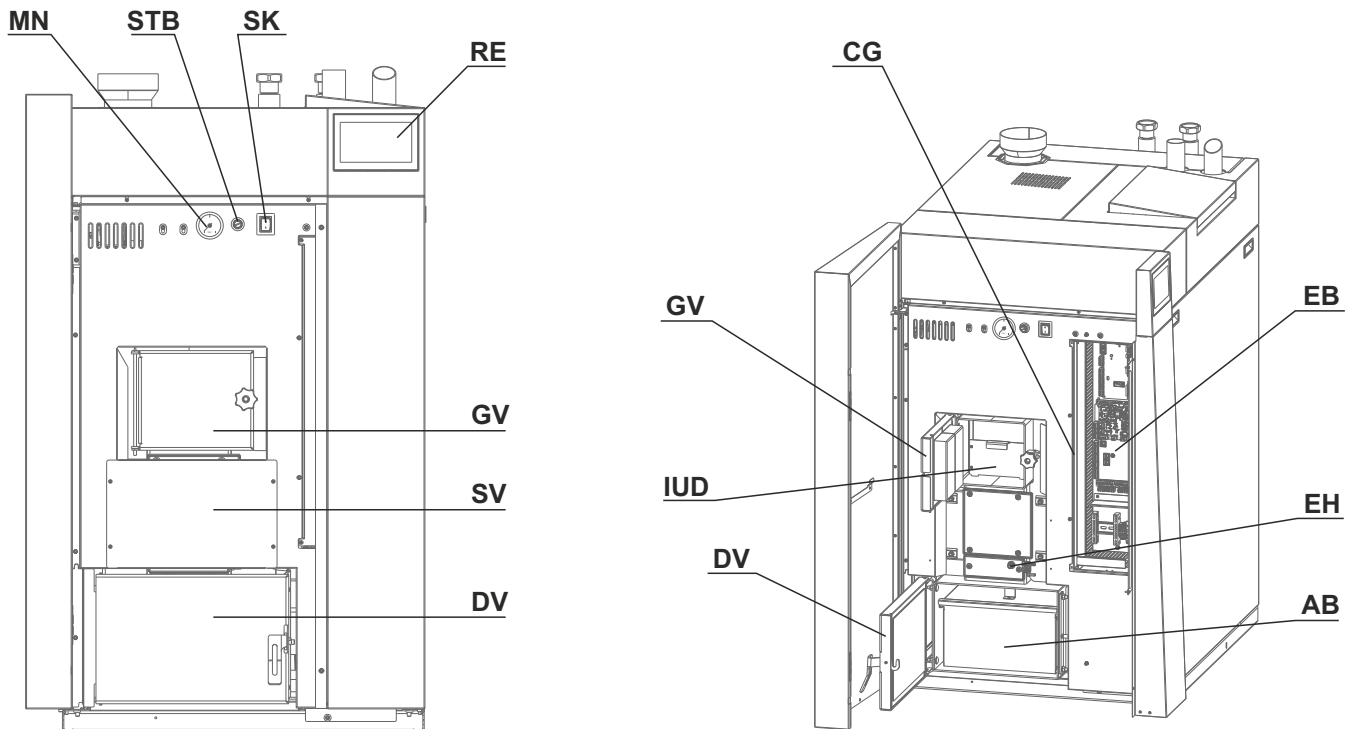
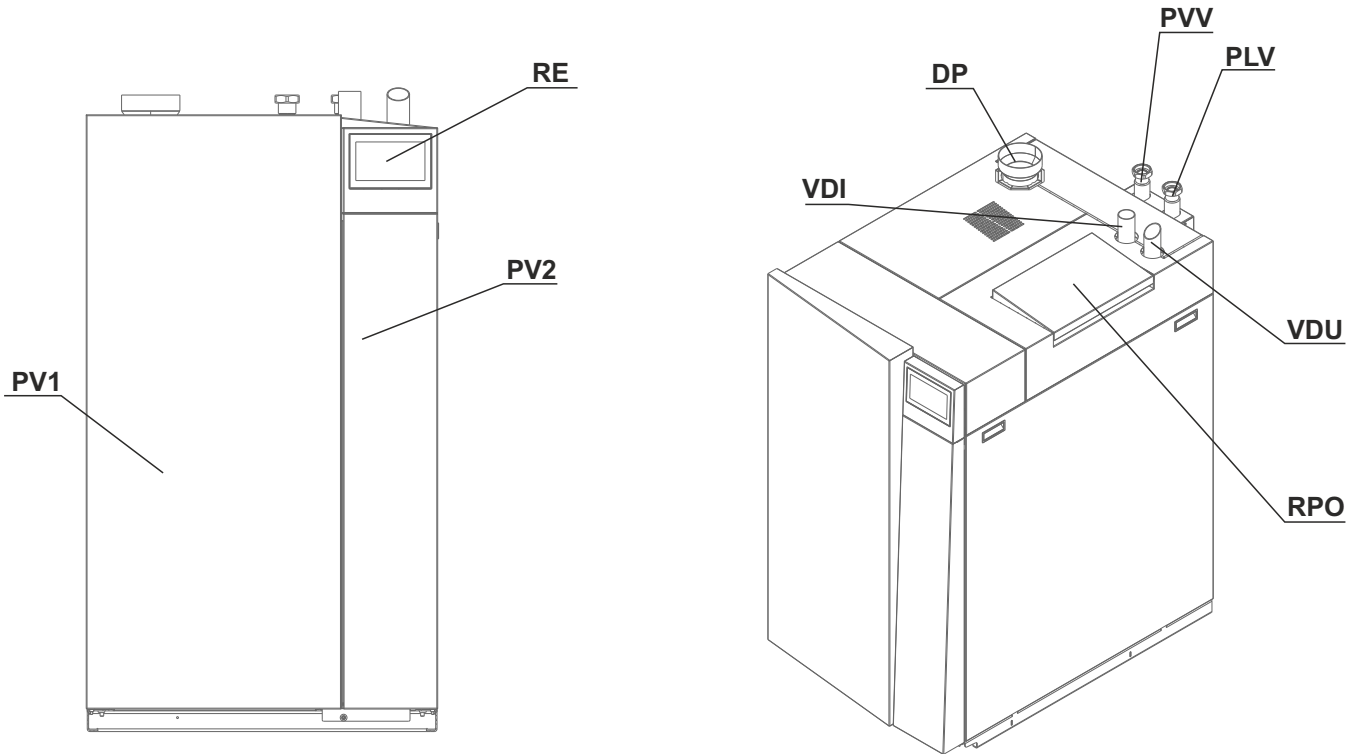

Side view (without side, back and upper metal boiler cover)

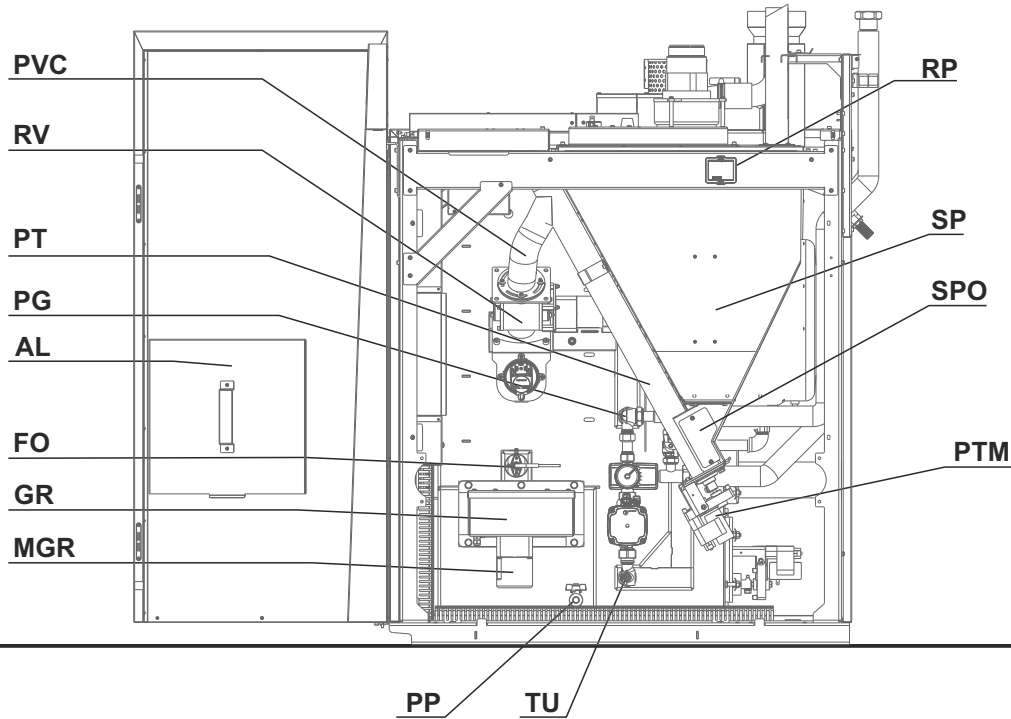

Back view

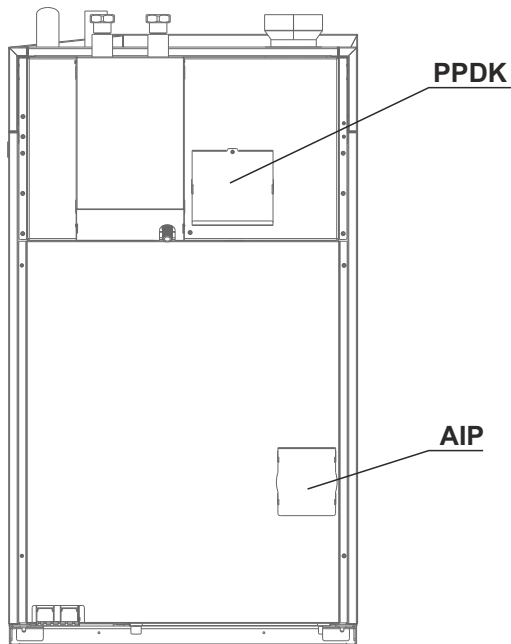

Back view (without side, back and upper metal boiler cover)

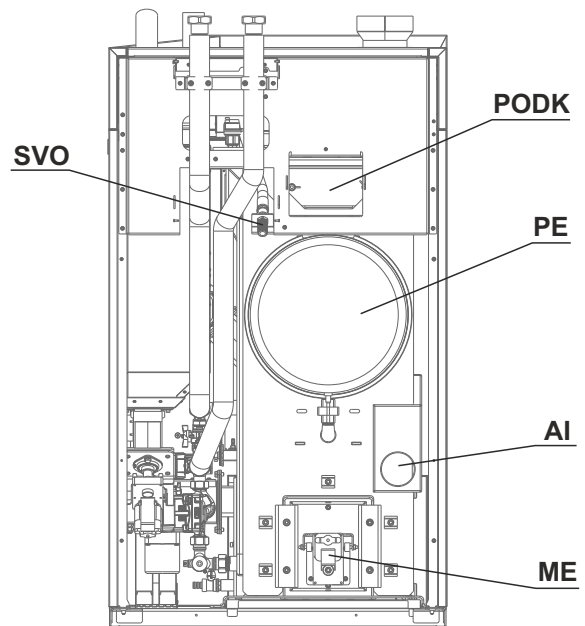

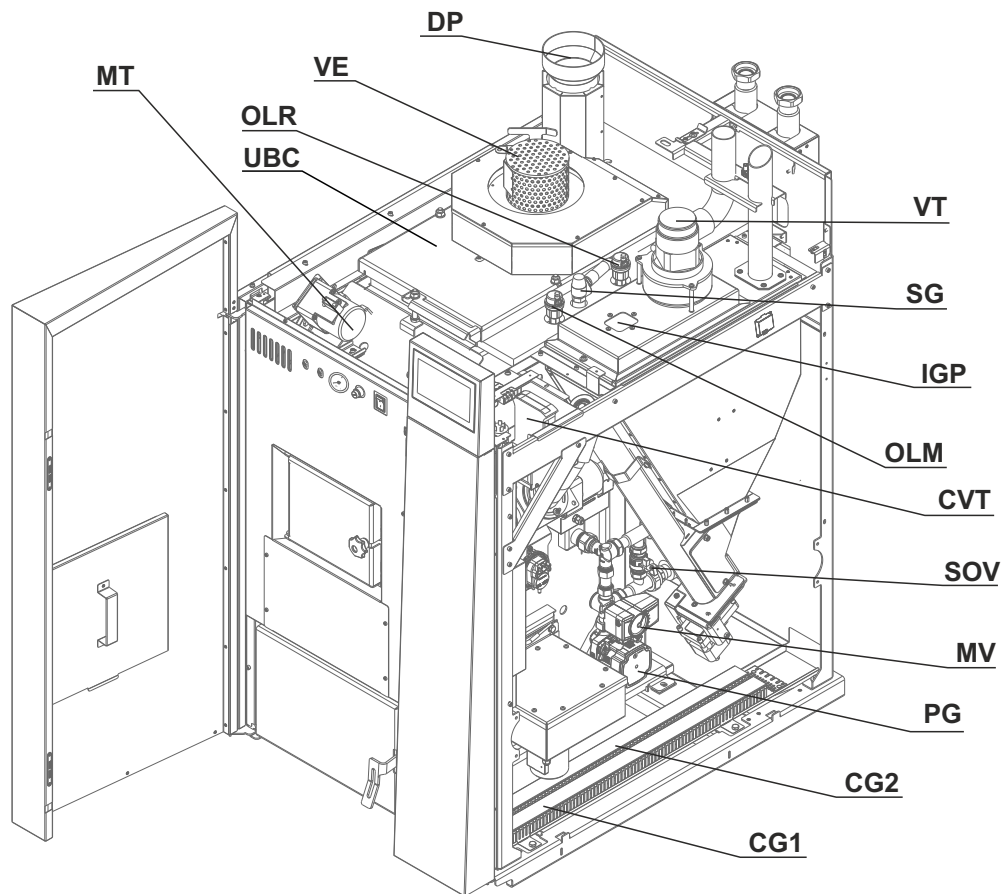

LEGEND:

- AB** - Ash box
- AI** - Fresh air inlet (Φ 80)
- AIP** - Perforated part - Fresh air inlet
- AL** - Ash box lid
- CG1** - Cable groover - 230 V
- CG2** - Cable groover - low voltage
- CVT** - MODULE CVT for control of the vacuum suction system
- DP** - Flue gas tube
- DV** - Lower boiler door
- EB** - Junction (electric) box (jbox) without cover
- EH** - Electric heater (behind cover)
- GR** - Grate cleaning mechanism cover
- GV** - Upper boiler door
- IGP** - Inspection glass for checking the pellet level in the pellet tank
- IUD** - Insert - upper door opening
- ME** - Ash extraction mechanism - heat exchanger
- MGR** - Grate cleaning mechanism motor
- MN** - Pressure gauge (manometer)
- MT** - Turbulators motor - (cleaning system)
- MV** - Mixing valve (actuator)
- OLM** - Air vent valve (main flow)
- OLR** - Air vent valve (return flow)
- PE** - Expansion vessel
- PG** - P(PWM) - (Boiler circuit)
- PLV** - Boiler flow connection
- PODK** - Cover of the opening for cleaning the flue gas box
- PP** - Discharge
- PPDK** - The cover of the passage to the lid for cleaning the flue gas box
- PT** - Pellet feeder
- PTM** - Pellet feeder motor
- PV1** - Front left cover boiler door
- PV2** - Front right cover boiler door
- PVC** - PVC connecting pipe (Pellet feeder - Rotary valve)
- PVV** - Boiler return connection
- RE** - Control unit screen
- RP** - Pellet level sensor
- RPO** - Cover lid for revision
- RV** - Rotary valve
- SG** - Safety valve
- SK** - Main switch
- SOV** - Shut-off valve (open/closed boiler hydraulic crossover)
- SP** - Pellet tank
- SPO** - Opening for cleaning the pellet tank
- STB** - Safety thermostat
- SV** - Middle cover of the boiler
- SVO** - Safety valve outlet
- TU** - Temp. sensor tube (probe)
- UBC** - Upper boiler cover
- VDI** - Air and dust suction system (outlet)
- VDU** - Pelet suction system (inlet)
- VE** - Flue gas fan
- VT** - Vacuum suction system (Vacuum turbine)

BASIC ELECTRICAL PARTS AND SENSORS

- | | |
|---|--|
| <ul style="list-style-type: none"> 1 - Boiler sensor (NTC 5k) 2 - Heating circuit K1/K2 temperature sensor / accumulation (buffer) tank temperature sensor (NTC 5k) 3 - Pressure switch 4 - Photocell 5 - Electric heater 6 - Flue gas sensor (Pt 1000) | <ul style="list-style-type: none"> 7 - Fan speed (rpm) sensor 8 - Fuel level sensor in pellet tank 9 - Heating circuit K1/K2 temperature sensor / accumulation (buffer) tank temperature sensor (NTC 5k) 10 - Return flow temp. sensor (NTC 5k) 11 - Lambda probe 12 - Outdoor temp. sensor (NTC 5k) |
|---|--|

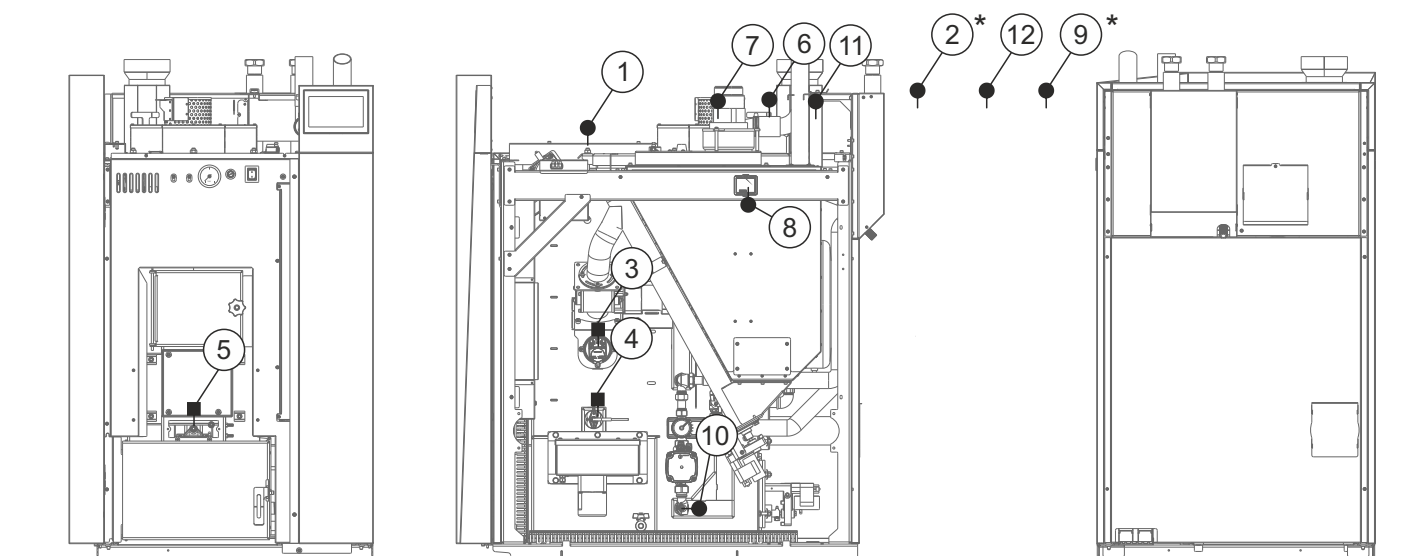

* depending on the configuration can be used as: Heating circuit K1/K2 temperature sensor / accumulation (buffer) tank temperature sensor

ADDITIONAL EQUIPMENT

CAL - alarm box (speaker/ LED)



CM2K module for control unit 2+ heating circuits



CMNET module for boiler cascade



Room corrector (CSK-Touch)



Dust extraction cyclone for pellet suction feeding system (type: CVDOP)



1.0. INTRODUCTION

The **PelTec-Compact** has a modern construction and design and is made out of the controlled materials of high quality, welded with most modern technology and is approved and tested under EN 303 - 5 norm and fulfill all special request for the connection on the installation of a central heating system.

1.1. BOILER DESCRIPTION

Steel hot water boiler are engineered for wood pellet firing. In the boiler is installed the burner for wood pellet firing with the automatic firing and automatic self-cleaning function which enables the reliable operation also with the low quality wood pellets. The function of the automatic cleaning flue gas tubes provides the unifying exchange of the heat and high and unifying level of boiler efficiency. Digital boiler controller in a basic construction offers also the possibility of control with the lambda probe or level control of the wood pellets in the pellet tank. The pellet tank is the integral part of the boiler. The boiler is delivered in pieces due to the easier transport into the boiler room.

1.2. SAFETY PRECAUTIONS

The boiler and related accessories are state of the art and meet all applicable safety regulations. The control unit, wiring chamber, el. heater, safety cut-out STB thermostat, fan, grid cleaning mechanism, flue gas tubes cleaning mechanism and pellet supply mechanism are integrated into the **PelTec-Compact**. They are operate at a voltage of 230 V AC. Improper installation or repair can pose the danger of life-threatening electric shock. Installation may be performed only by appropriately qualified technicians.

Caution symbols:

Please take careful note of the following symbols in this Technical instructions.



This symbol indicates measures for protection against accidents and warning for the user and / or exposed persons.

1.3. IMPORTANT INFORMATIONS

All local regulations, including those referring to national and European standards need to be complied with when installing the appliance.

The boiler must not be modified unless using the tested original accessories we provide or if the work is undertaken by our Customer Service.

Only fit original spare parts. These can be obtained from your customer service partner or directly from ourselves. European standards need to be complied with when installing the appliance.

Regular care and cleaning of the appliance, flue gas outlets, connecting piece and flue.



CAUTION:

The flue may block if the boiler is heated again after a long period of it not being used. Before starting the boiler, have the flue checked by a specialist (chimney sweep).

Ensure sufficient supply of fresh air in the installation room when heating. The air must be replaced at least 0.8 times an hour through constant and reliable room venting. Fresh air may have to be provided from outside if the windows and doors in the room where the boiler is installed are well sealed or if this room contains other equipment, such as extractor hoods, clothes dryer, fan etc.

1.4. STATUS OF DELIVERY

Delivery package include:

Boiler PelTec-Compact (covered with casing with thermal insulation) on wood pallet with inbuilt and pre-wired:

- 7" color touch screen display control unit
- boiler temperature sensor - NTC 5K - PVC I=1000 (12041)
- flue gas temperature sensor - PT 1000 - Teflon I=1700 (62330)
- 1 x return flow temperature sensor - NTC 5K - PVC I=2000 (26226)
- pellet level sensor in the pellet tank - CMSR 50
- safety thermostat
- pressure switch
- photocell
- lambda probe
- flue gas modulating fan
- rotary valve
- pump group (Tubes with 3-way mixing valve with actuator and pwm-circulation pump)
- grate cleaning mechanism
- vacuum suction system (vacuum turbine)
- expansion vessel (V= 18 liters)
- air vent valve (main flow)
- air vent valve (return flow)
- safety valve

Additional sensors and equipment in basic delivery:

- 1x outdoor temperature sensor - Outdoor temperature sensor NTC 5K (31428)
- 1 x (Heating circuit K1/K2 temperature sensor / accumulation (buffer) tank temperature sensor) - NTC 5K - PVC I=2000 (26226)
- 1 x (Heating circuit K1/K2 temperature sensor / accumulation (buffer) tank temperature sensor) - NTC 5K - PVC I=2000 (32685)
- scraper, wooden cleaning brush, wire cleaning brush, holder for cleaning set

Obligatory additional delivery (not included in the basic delivery):

- flexible PVC tubes for vacuum system
- mole + pellet tank / CentroPelet Box / Screw feeder + pellet tank

1.5. SETTING PHOTOCELL TO THE WORK POSITION



Before first startup, be sure to set the photocell to the position as on the figures below, otherwise the boiler will not work properly!

The photocell should not be set too deep or too shallow in the box. Because of this, there is a limiter by which correct photocell depth is set. Check if the limiter is adjusted according to the photos below.

Factory installation position and distance photocell flange and limiter, ready for installation

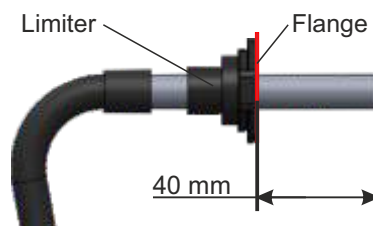

Carefully install photocell into flange on the box to the limiter (so it clicks)

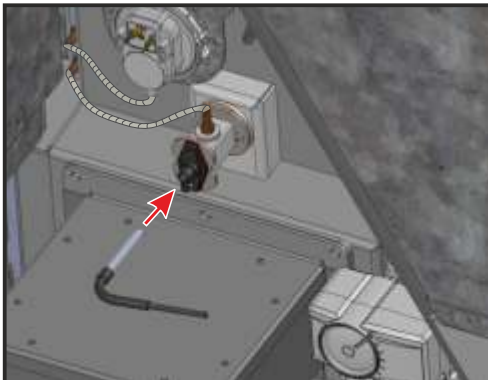

Correctly installed photocell
Boiler ready for operation



1.6. SAFETY ELEMENTS

Boiler have a few safety elements:

- **Pressure switch** - if there is no underpressure in the boiler (eg. chimney is not passable, any boiler door or cleaning opening is open or the PVC pellet supply pipe is punctured), the controller displayed E12 and "Safety pressure switch", and the boiler stops working.
- **Photocell** - in case there is no flame (photocell does not see flame) in the ignition phase at the set time, the controller displays E18 and "No flame in ignition stage" and stops the boiler, if the flame disappears in the ignition phase, the control displays E23 and "Flame disappeared in ignition stage" and stops the operation of the boiler, if the flame disappears in the stabilization phases, the controller displays E24 and "Flame disappeared stabilization stage" and stops the boiler, and if the flame disappears in the phases of boiler operation, the controller displays E19 and "Flame disappeared working phase" and stops the boiler operation.
- **Controller** has a built in protective function which protects the boiler against overheating. If temperature in the boiler exceeds 93 °C, regardless heating or sanitary water is needed the boiler pump and/or the sanitary water turns on and works until temperature in the boiler falls below 93 °C.
- **The fan** has a built-in RPM counter and, if control unit is informed that the fan does not operate in accordance with the requirement interrupts the process display error E13 and "Fan error".
- **The grate cleaning mechanism** has built-in microswitch that monitor the position of the grate. If the grate is not in the required position at a certain moment, the controller receives this information and interrupts the operation process, and E21 and "Error grate cleaner" will appear on the display.
- **Flue gas connection** have in-built sensor for flue gas temperature measuring. If flue gas tube temperature is over 300 °C, controller interrupt proces and display information E4 and "Flue gas sensor error".
- **STB thermostat** - When temperature in the boiler exceeds 110°C (+0°C / - 6°C), power supply is turned off by the safety thermostat (STB).
- **Rotary valve** - Backfire protection valve (RSE).

1.7. FUEL

Only wood pellets are used as fuel in PelTec-Compact. Wooden pellets are bio-fuel made of wooden wastes. Pellets can be packed in different packaging: in bags (15 kg or 1000 kg), or as bulk in large (underground) tanks (4 - 15 m³) or in basement spaces. Pellets used in pellet boiler must be in accordance with following norms: ENplusA1, DINplus, ONorm-M-7135 or DIN 51731.

Recommended properties of pellets are following:

- heating value \geq **5 kWh/kg** (18 MJ/kg)
- diameter \leq **6 mm**
- max. lenght = **50 mm**
- max. moisture content \leq **12 %**
- max. dust content \leq **1,5 %**.

2.0. BOILER POSITIONING AND ASSEMBLY

Boiler positioning, assembly and building in must be performed by a qualified person. We recommend that boiler is placed on a concrete base with height of 50 to 100 mm above the floor. Boiler room must be frost-proof and well ventilated. Boiler has to be positioned so that it can be properly connected to the chimney (see Figure 1a) and simultaneously, enabling tending of boiler and additional equipment, control during operation, cleaning and maintenance.

WARNING!

Flammable items must not be placed on the boiler and within the minimum distances shown in Figure 1a and 1b.

2.1. MINIMUM DISTANCE FROM THE ROOM WALLS

Figure 1a. Minimum distance from the room walls for PelTec-Compact

PelTec-Compact 12-24

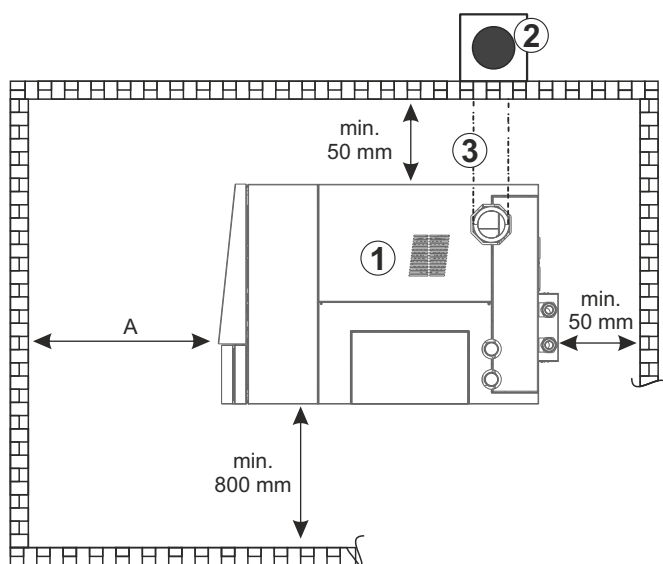

- ① - Boiler PelTec-Compact
- ② - Chimney
- ③ - Flue gas tube (Chimney connection; must be insulated)
- Ⓐ - 12 kW = min 520 mm
18 kW = min 620 mm
24 kW = min 620 mm



Provide minimum distance from the boiler room ceiling and walls for undisturbed cleaning.

Figure 1b. Minimum distance from the boiler room ceiling.

PelTec-Compact 12-24 kW

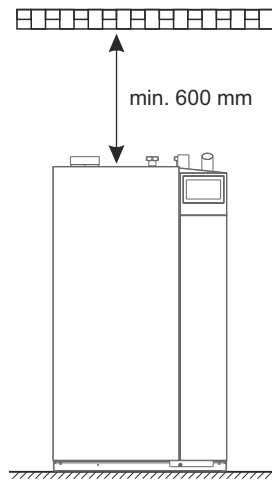

3.0. CONNECTION TO THE CHIMNEY

3.1. INSTALLATION OF BOILERS WITH COMBUSTION AIR SUPPLY FROM OUTSIDE THE BUILDING



Only flue elements and fresh air supply elements that have been declared by the manufacturers of these elements to be airtight by connecting them may be installed.

All connections of flue elements and fresh air supply elements, including the connection to the boiler, must be airtight.

All local regulations, including those referring to national and European standards need to be complied with when connecting the boiler to the chimney and air supply.

It is necessary to ensure the drainage of condensate from the chimney.

The following Figures illustrate possible installations for boilers with combustion air supply outside the building.

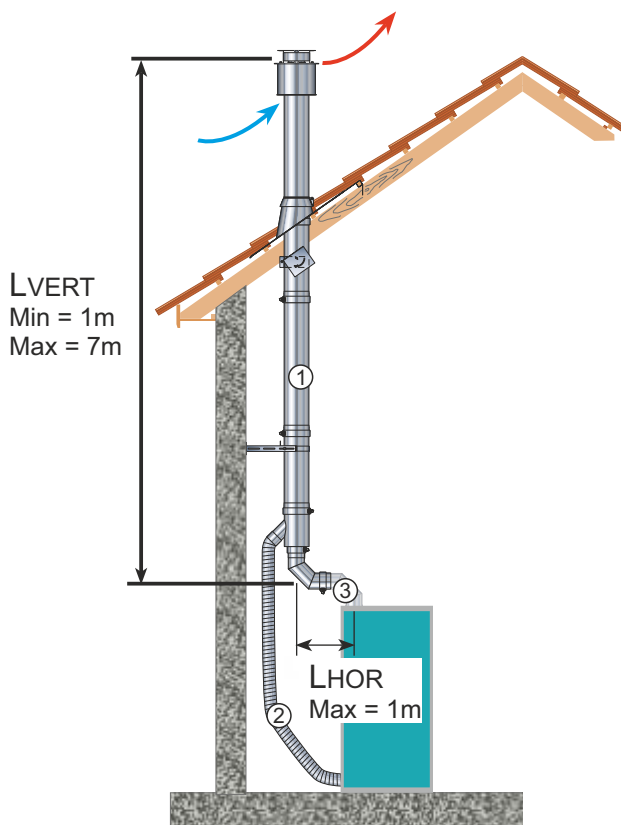

Fig. 2. Terminal-vertical, chimney inside the boiler room

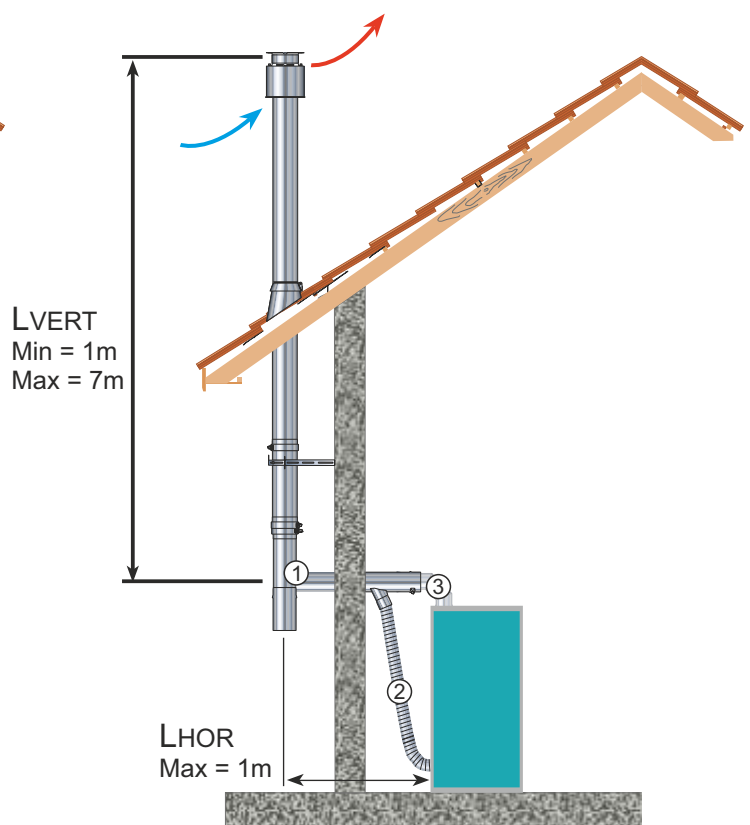

Fig. 3. Terminal-vertical, chimney outside the boiler room

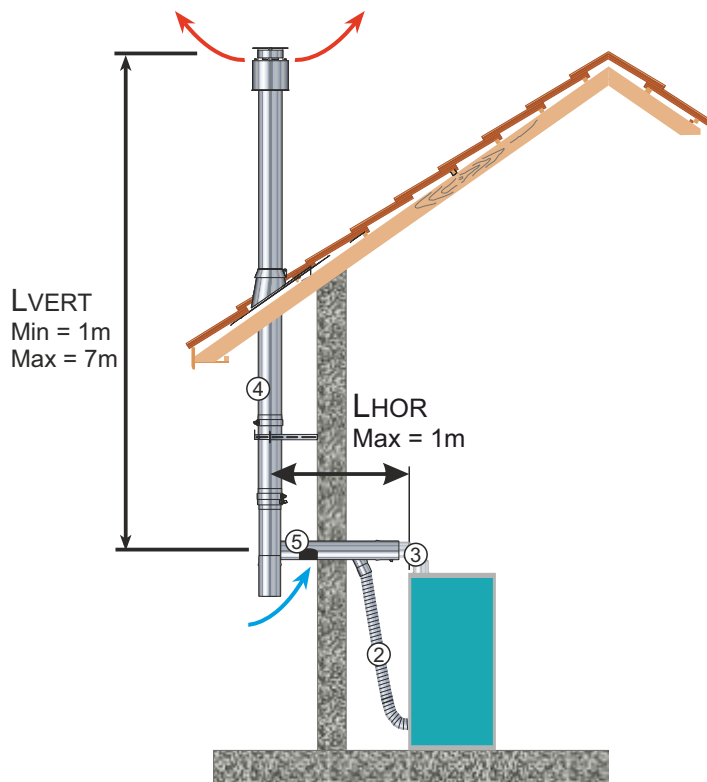

Fig. 4. Fresh air from the facade

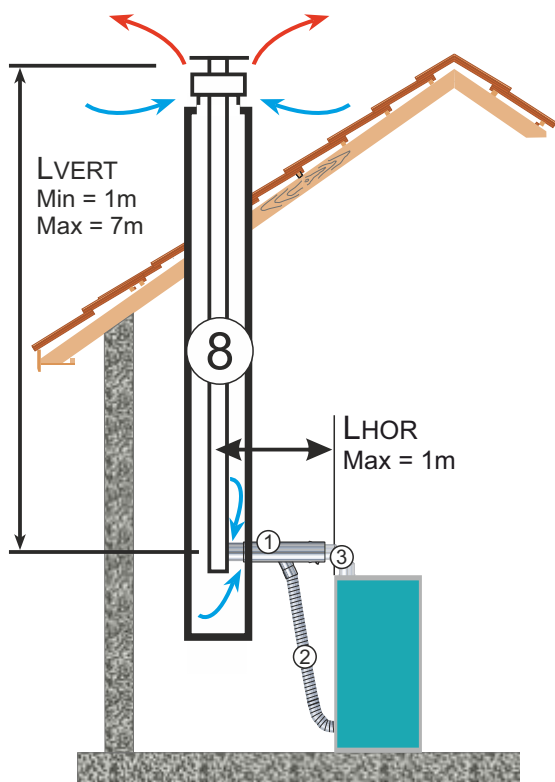

Fig. 5. Concentric flue gas tube (chimney inside the boiler room)

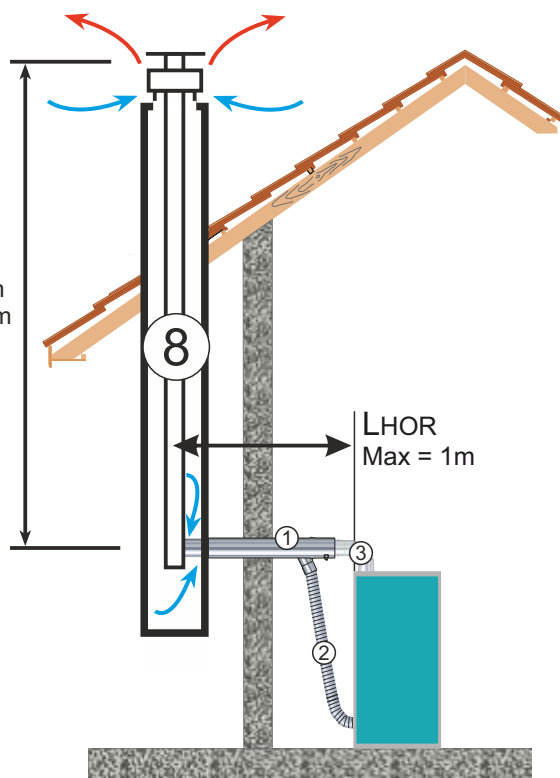

Fig. 6. Concentric flue gas tube (chimney outside the boiler room)

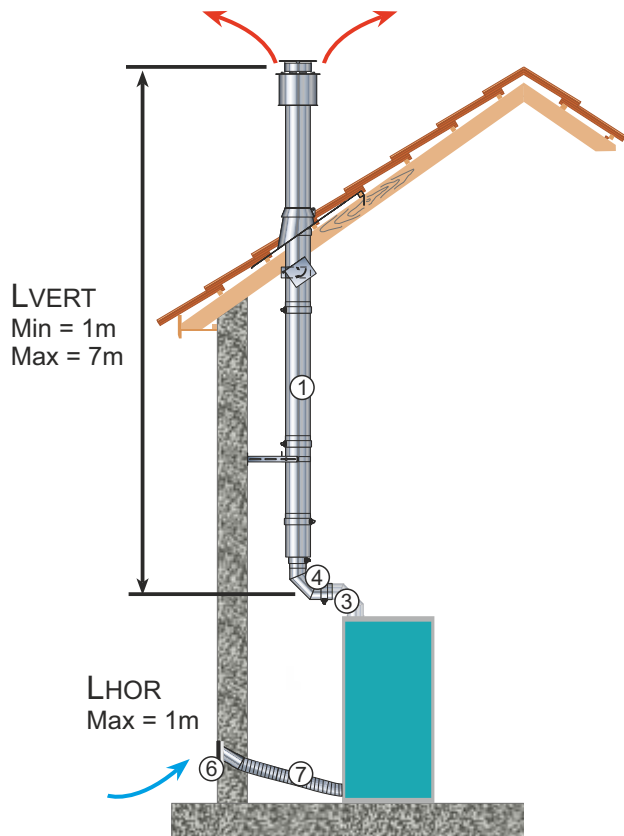

Fig. 7. Fresh air from the facade - wall grille, chimney inside the boiler room

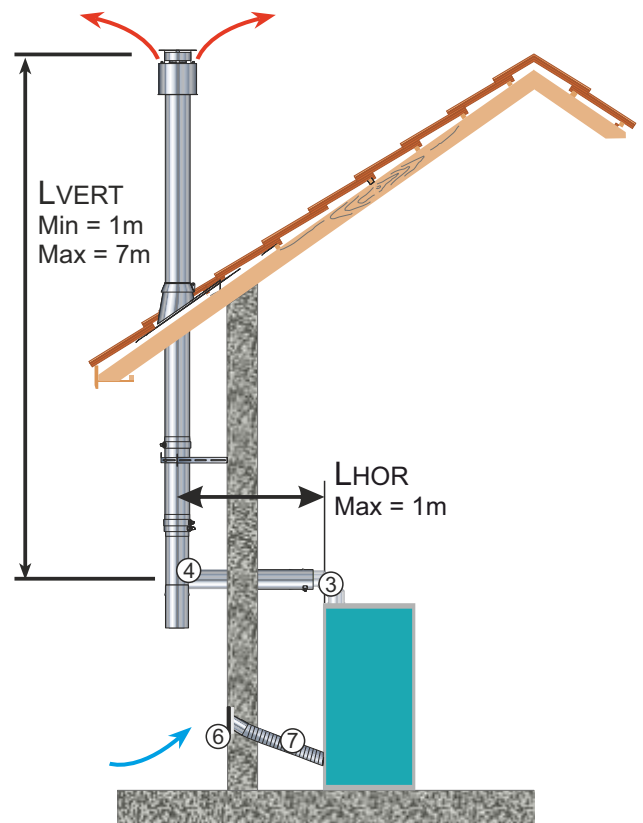

Fig. 8. Fresh air from the facade - wall grille, chimney outside the boiler room

Legend:

Lhor_max = 1m
 LVER = Lhor + Lvert

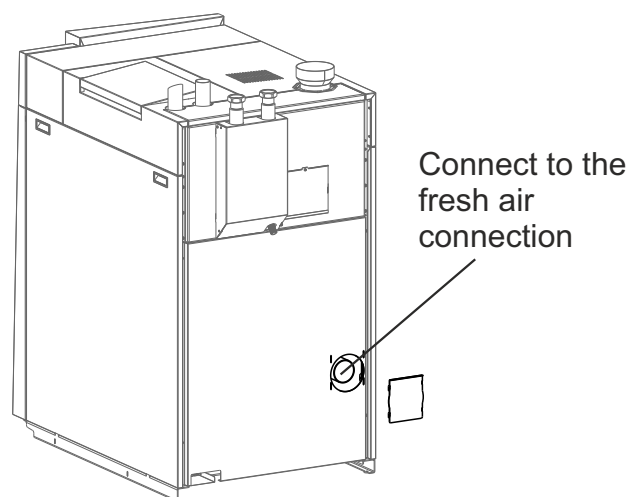
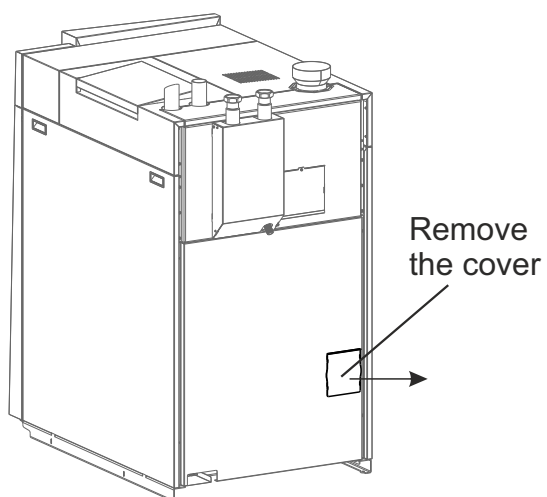

- ① Diameter of flue gas tube / Diameter of tube for fresh air (mm):
 PelTec-Compact 12 = 100/150. It must be thermally insulated.
 PelTec-Compact 18, 24 = 130/200. It must be thermally insulated.
- ② Fresh air tube diameter (mm): 80
- ③ Flue gas tube (flue gas elbow) diameter (mm):
 PelTec-Compact 12 = 100. It must be thermally insulated.
 PelTec-Compact 18, 24 = 130. It must be thermally insulated.
- ④ Flue gas tube, flue gas T-piece diameter (mm):
 PelTec-Compact 12 = 100. It must be thermally insulated.
 PelTec-Compact 18, 24 = 130. It must be thermally insulated.
- ⑤ Diameter of flue gas tube / Diameter of tube for fresh air from the facade (mm):
 PelTec-Compact 12 = 100/150. It must be thermally insulated.
 PelTec-Compact 18, 24 = 130/200. It must be thermally insulated.
- ⑥ Fresh air wall grille with min. opening area $6,02 \times Q$ cm² (Q - boiler output in kW)
- ⑦ Fresh air tube diameter (mm): 80;
- ⑧ Diameter of flue gas tube / Diameter of tube for fresh air:
 PelTec-Compact 12 = 100/150. Or two tubes 100 mm. It must be thermally insulated.
 PelTec-Compact 18, 24 = 130/200. Or two tubes 130 mm. It must be thermally insulated.

Connection of fresh air from outside the boiler room to the boiler



Local regulation for France:

TERMINAUX POUR CHAUDIÈRES À GRANULÉS DE BOIS ÉTANCHES DE PUISSANCE < À 70 KW

-  Zones interdites
-  Zones autorisées

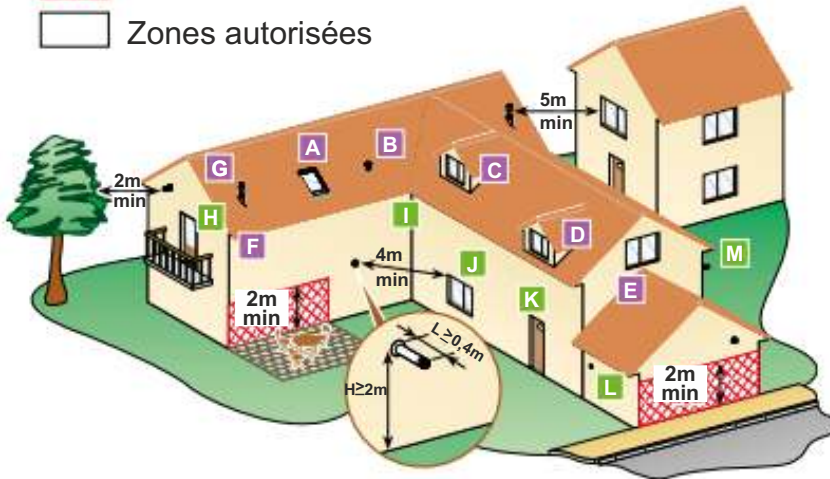

FAÇADE

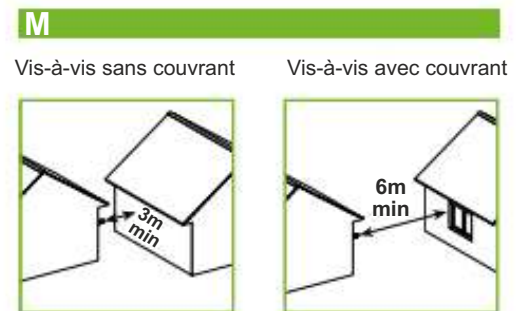
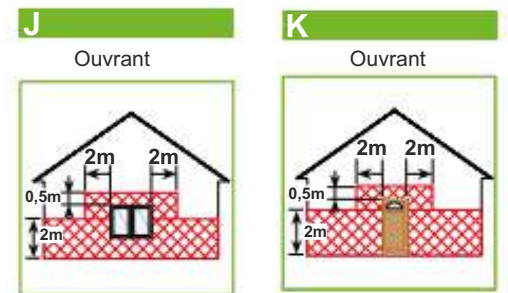
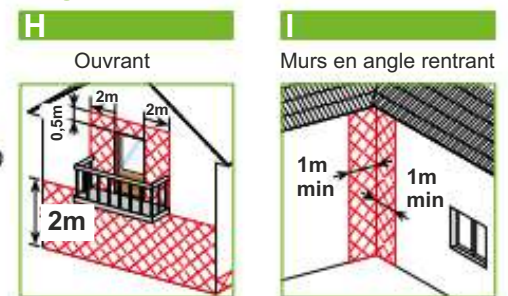

TOITURE

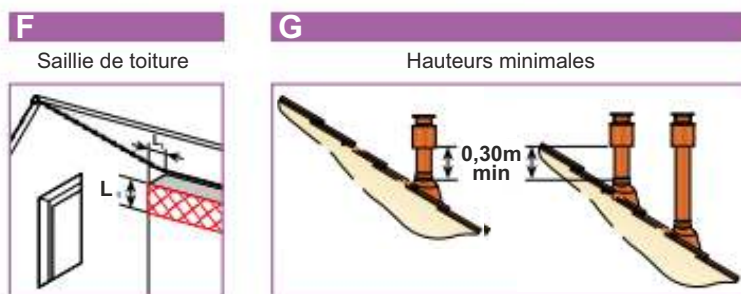
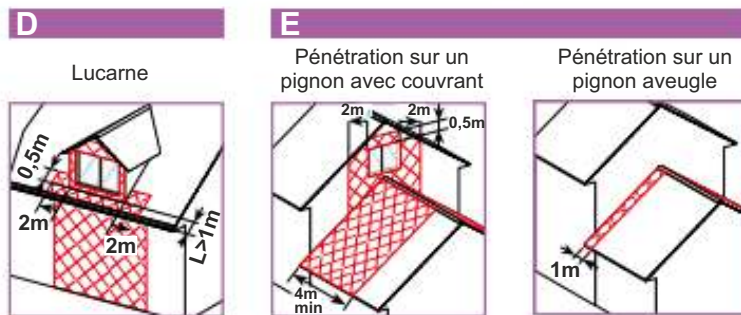
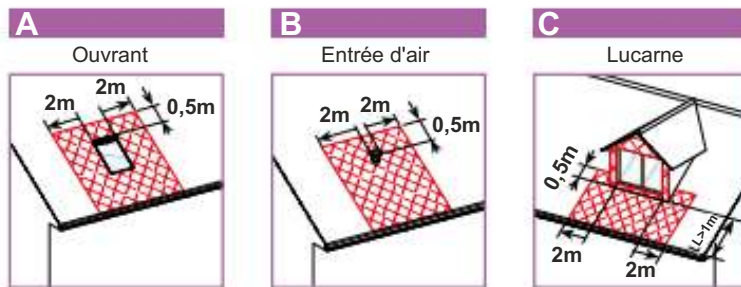

3.2. INSTALLATION OF BOILERS WITH COMBUSTION AIR SUPPLY FROM INSIDE THE BOILER ROOM



CAUTION:

The flue may block if the boiler is heated again after a long period of it not being used. Before starting the boiler, have the flue checked by a specialist (chimney sweep). Ensure sufficient supply of fresh air in the installation room when heating. The air must be replaced at least 0.8 times an hour through constant and reliable room venting. Fresh air may have to be provided from outside if the windows and doors in the room where the boiler is installed are well sealed or if this room contains other equipment, such as extractor hoods, clothes dryer, fan etc.

3.2.1. OPENING FOR FRESH AIR (FRESH AIR SUPPLY)

Each boiler room **must be equipped with an opening** for supply of fresh air which is dimensioned in accordance with boiler output (minimum opening area according to the below shown equation). Such opening must be protected with a net or grate. All installation works have to be performed in accordance with valid national and European standards. Boiler must not operate in flammable and explosive environment.

$$A = 6,02 \times Q$$

A - opening area in cm²
Q - boiler output in kW

3.2.2. CONNECTION TO THE CHIMNEY



The chimney must be resistant against flue condensate!

All local regulations, including those referring to national and European standards need to be complied with when connecting the boiler to the chimney and air supply.

Properly dimensioned and built chimney is the main condition for safe and economical functioning of the boiler. The thermal insulation of the chimney has to be done properly, it has to be absolutely gas-proof and smooth. On its lower part there has to be built in the opening for cleaning with the door. An brick-layed chimney has to have three layers with an insulation of 30 mm in the middle, if the chimney is built inside the house (i.e. inside the heated area), or an insulation of 50 mm if it is built outside the house (i.e. outside the heated area). The flue gas temperature has to be at least 30°C higher then the temperature of their condensation point. The choice and the construction of the chimney has to be performed by the authorized person. Inner diameter of the chimney must be selected according the possible effective chimney height and boiler power and according diagram below.

The chimney must be dimensioned according to the "chimney selection diagram" with minimum inner clear cross-section of the connection between the boiler and the chimney of Φ 100 mm for PelTec-Compact 12 and Φ 130 mm for PelTec-Compact 18/24. The diagram was made for a chimney length of 2 m with two 90° elbows (bends). If the chimney does not fit into the specified frame, the chimney must be raised according to the guidelines in the note below the diagram. Connection flue gas tube can be mounted horizontally or at any angle which allows to gas, on his way to chimney, a constant increase of height with considering of exit point from fan. Connection flue gas tube must have openings for cleaning through which is possible to clean entire length of flue gas tube or must ensure easy removal part of flue gas tube which allow complete cleaning of connection flue gas tube. To prevent entry of condensate form chimney into the boiler, flue gas tube must be mounted 10 mm deeper into the chimney. **Connection flue gas tube between fan and chimney must be insulated with 30-50 mm mineral wool.**

Figure 9. Dimensioning of the chimney for PelTec-Compact

12-24 kW

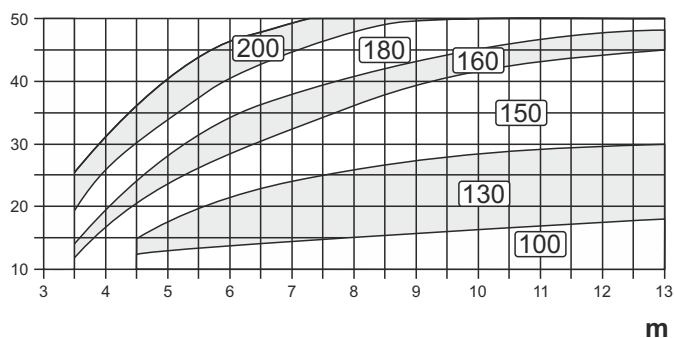

**Chimney dimensioning examples:
for boiler PelTec-Compact 12 and 24**

Boiler heat output: **12 kW / 24 kW**
 Required usable chimney height: **4,5 / 7,5 m**
 Required inner chimney diameter: **100 mm / 130 mm**
 Inner diameter of the boiler-chimney connecting pipe: **100 mm / 130 mm**
 Fuel: **wood pellets**

Chimney dimensioning examples:
 (minimum inner clear cross-section of the connection between the boiler and the chimney)

inner chimney diameter (mm)	boiler power (kW)		
	12	18	24
100	4,5	-	-
130	4,5	5,5	7,5
150	4	4,5	5,5
160	3,5	4	5
180	-	3,5	4
200	-	-	-
220	-	-	-
250	-	-	-

min. chimney effective height (m)

NOTES:

For flue gas tubes up to 2 m and 2 flue gas elbows look at the diagram.
 In case of longer flue gas tube or there is more than 2 flue gas elbows, effective height must be selected from the diagram and for every additional meter of the flue gas tube and/or every additional flue gas elbow, add following value to the effective height:
 - PelTec-Compact 12/18: +0,5 m
 - PelTec-Compact 24: +1,0 m

In case of flue gas tubes longer than 5 meters, recommended is (or it's necessary) select flue gas tube for 10 mm bigger than boiler output because of ash deposits during the boiler working.
 In any case, necessary is to predict correct amount cleaning openings for flue gas tube and elbows cleaning.

4.0. INSTALLATION

All local regulations, including those referring to national and European standards need to be complied with when installing the appliance.

4.1. CONNECTION TO CENTRAL HEATING SYSTEM

All installation work must be made in accordance with valid national and European standards.

Boiler **PelTec-Compact** must be built in closed central heating systems. Installation has to be made, in according to technical standards, by a professional who will be responsible for proper boiler operation. Before connecting boiler to central heating system, the system has to be flushed to remove impurities remaining after system installation. It prevents boiler overheating, noise within the system, disturbances at a pump and mixing valve. Boiler should always be connected to central heating system by connectors, never by welding. Figure 1. shows safe distances required for boiler cleaning and maintenance.

4.1.1. CONNECTION TO CLOSED HEATING SYSTEM

Schemes for possible configurations are on following pages.

4.1.2. SAFETY VALVE - CONNECTING THE DRAIN TO THE SEWER

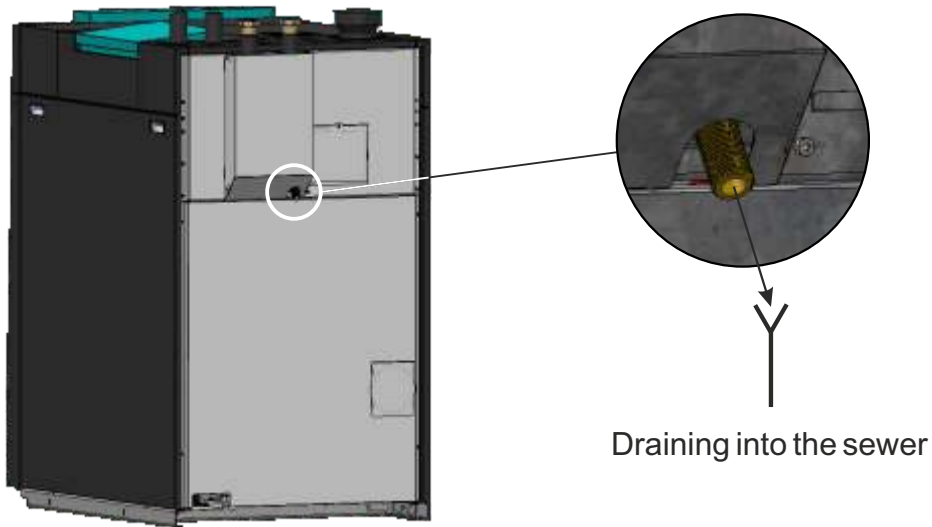

4.1.3. EMPTYING (DRAINAGE) OF THE BOILER / HEATING SYSTEM

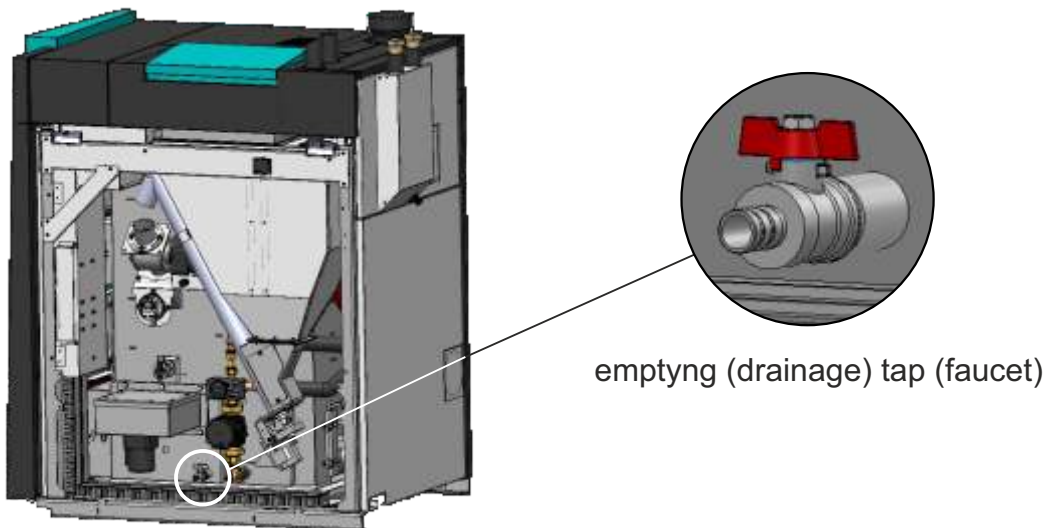

Note!
Filling is also possible through the same faucet.

Important!
The connection for filling the boiler/heating system must be made somewhere on the installation!

4.1.4. BOILER HYDRAULIC CROSSOVER OPEN/CLOSED

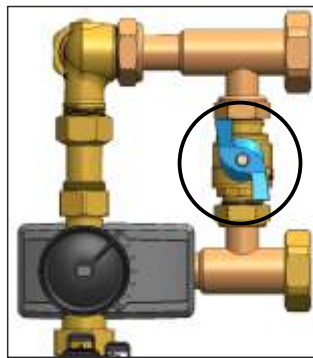
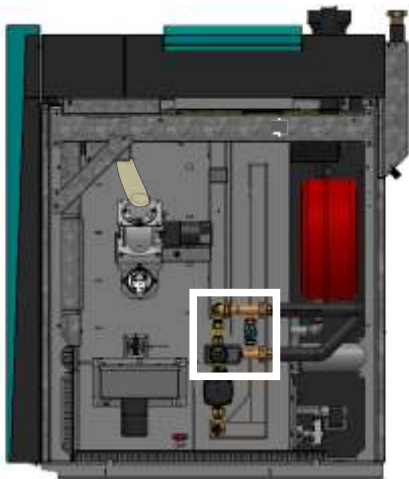

With boiler hydraulic crossover (open)
CRO ON

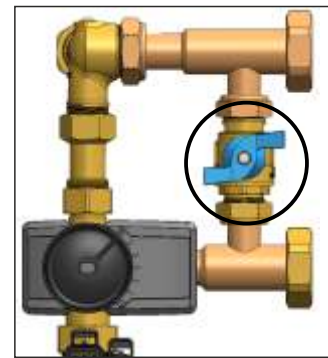

Without boiler hydraulic crossover (closed)
CRO OFF

4.1.5. BOILER AIRVENT

Figure 10. Water flow paths through the boiler

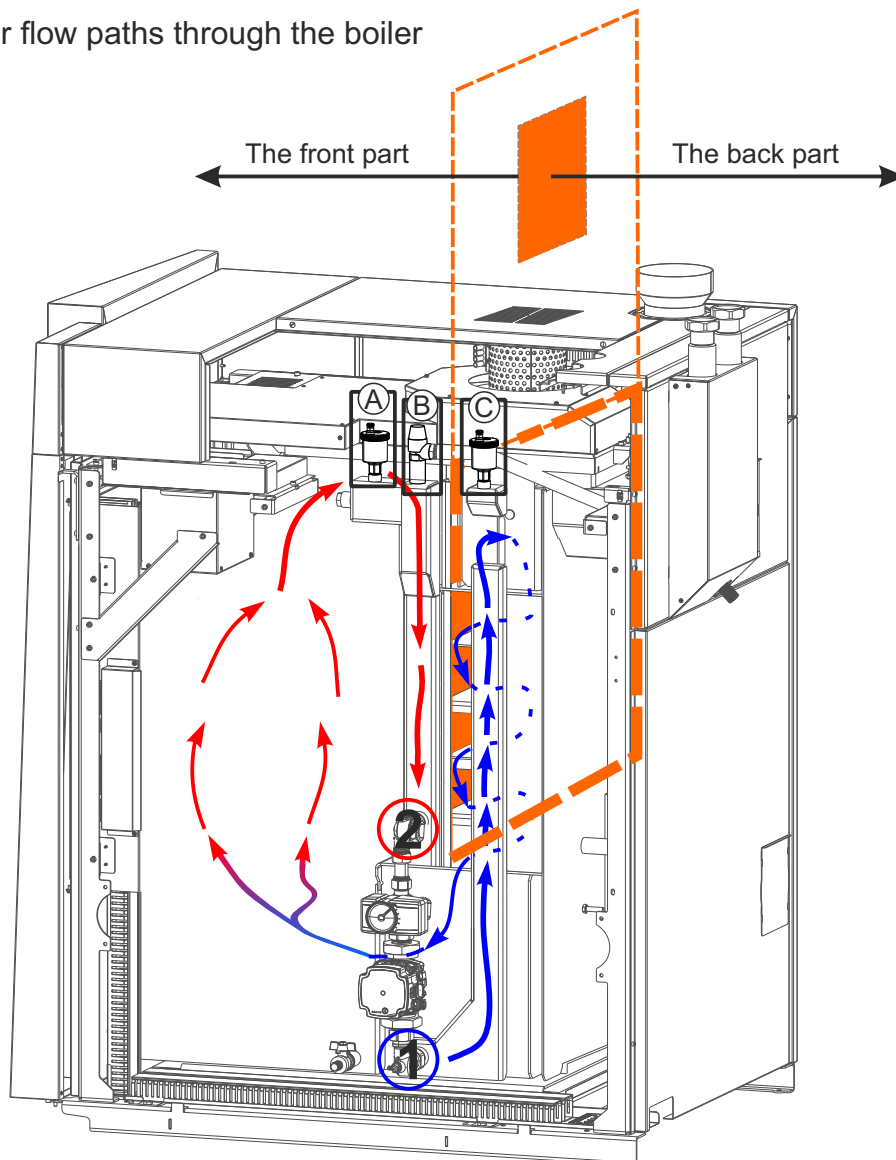

Important!

The front and back parts of the boiler are separated from each other on the upper side.

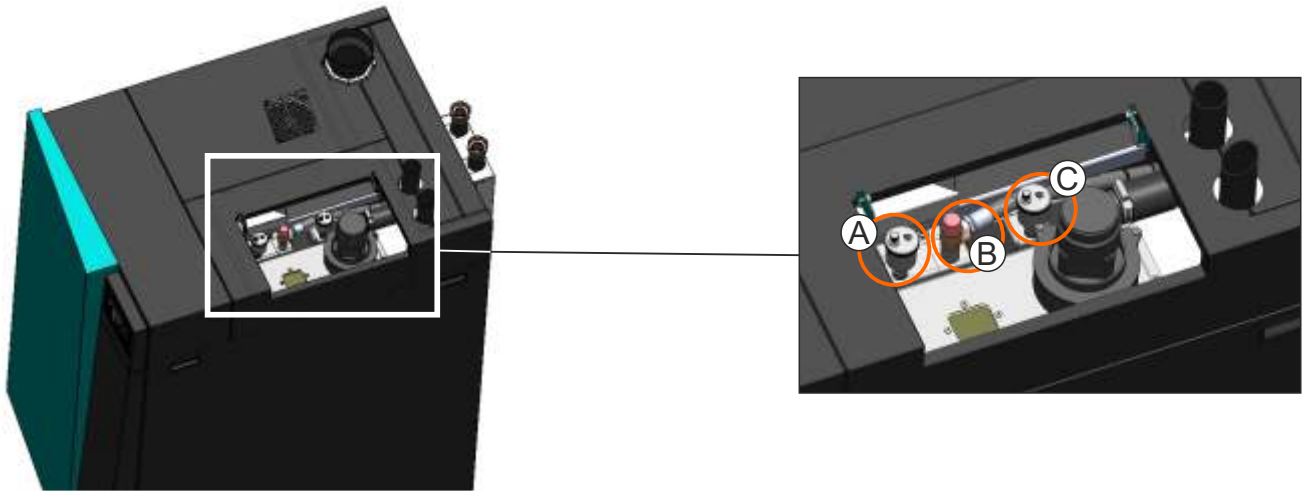

- 1 - Pump group connection (return flow)
- 2 - Pump group connection (main flow)

- A - Automatic air vent (The front part)
- B - Safety valve
- C - Automatic air vent (The back part)

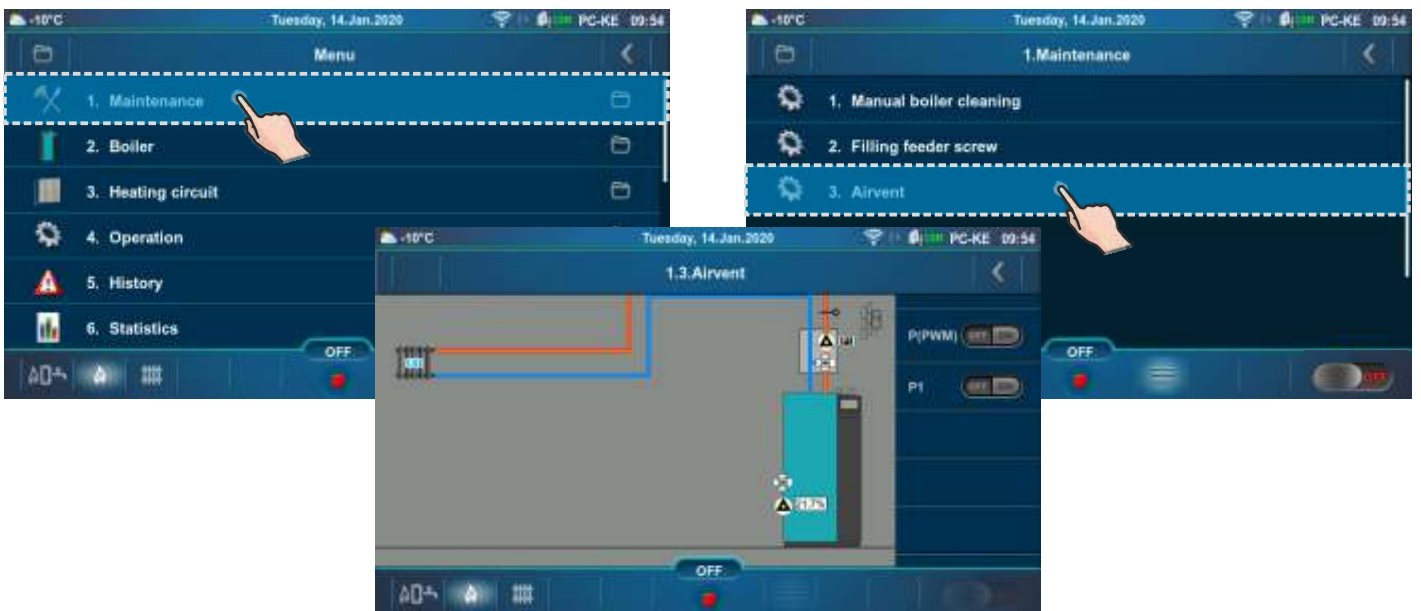

Important!

It is necessary to airvent both the front and back of the boiler well.

The front part of the boiler can be vented with an automatic air vent (A) and a safety valve (B), and the back part of the boiler can be vented with an automatic air vent (C). For venting, if necessary, use the Maintenance/Airvent firmware option.

4.1.6. MANIFOLD / PUMP GROUPS - POSSIBILITY OF INSTALLATION

PelTec-Compact 12

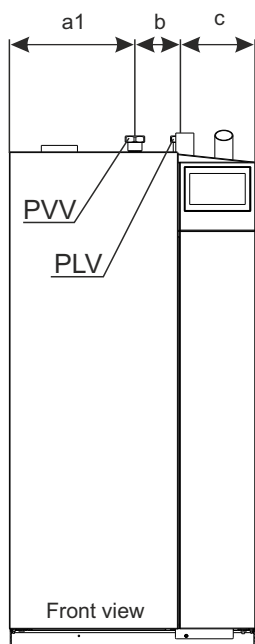

Without manifold and pump group

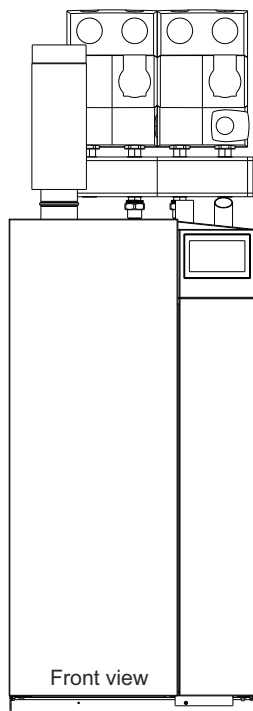

With manifold and pump group

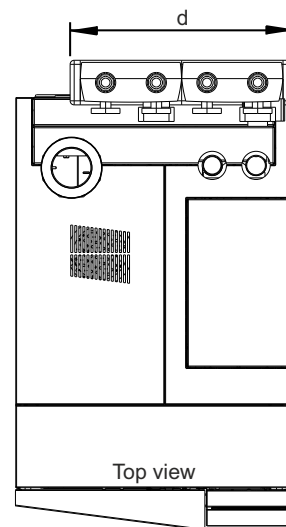

PelTec-Compact 18/24

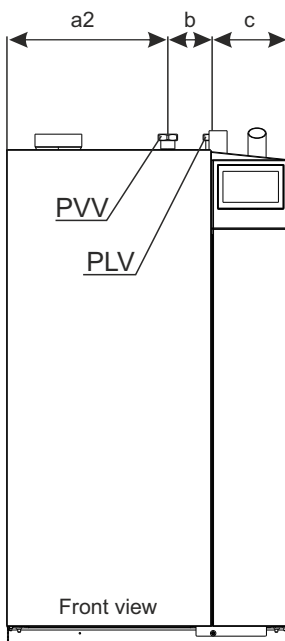

Without manifold and pump group

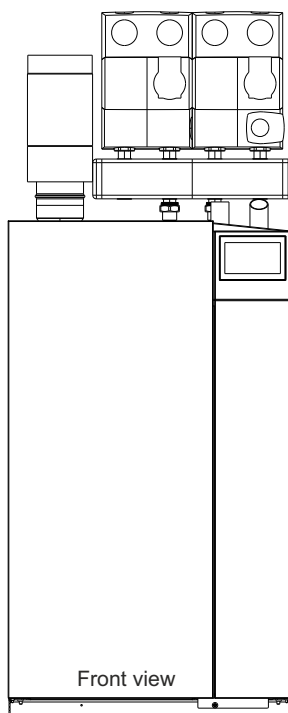

With manifold and pump group

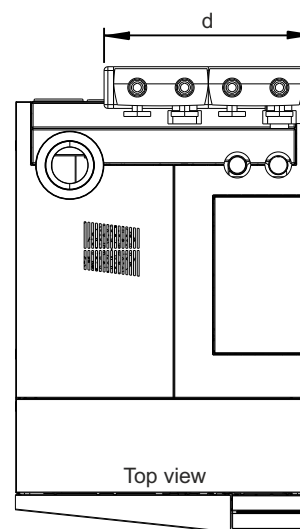

a1 = 350 mm
a2 = 450 mm

b = 125 mm

c = 210 mm

d = 550 mm

PLV - Boiler flow connection
PVV - Boiler return connection

4.2. CONFIGURATION / SCHEME - DESCRIPTION

Temperatures choice depends on the configuration of heating. Below are shown all types of installation and configuration.

Pump group
(direct heating system pump / DHW)



Pump group
(heating system pump with 3-way valve with actuator)



Pump groups
(direct heating system pump / DHW and heating system pump with 3-way valve with actuator)

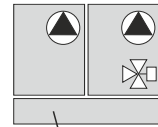

Manifold



MIXING VALVE
(3-way mixing valve with actuator - boiler circuit)

With boiler hydraulic crossover (open)

CRO ON

Without boiler hydraulic crossover (closed)

CRO OFF

P(PWM) - (Boiler circuit)
(boiler pump)
is located in the boiler

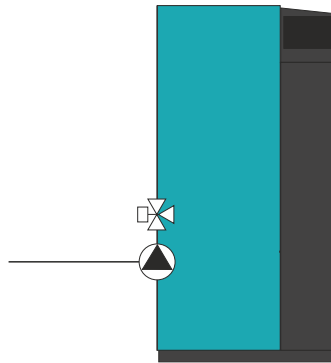

4.2.1. EXAMPLE OF SENSORS AND PUMPS CONNECTIONS (CONFIGURATION 1)

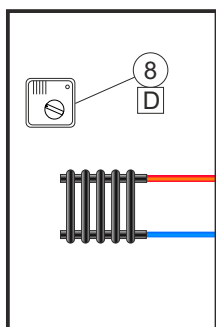
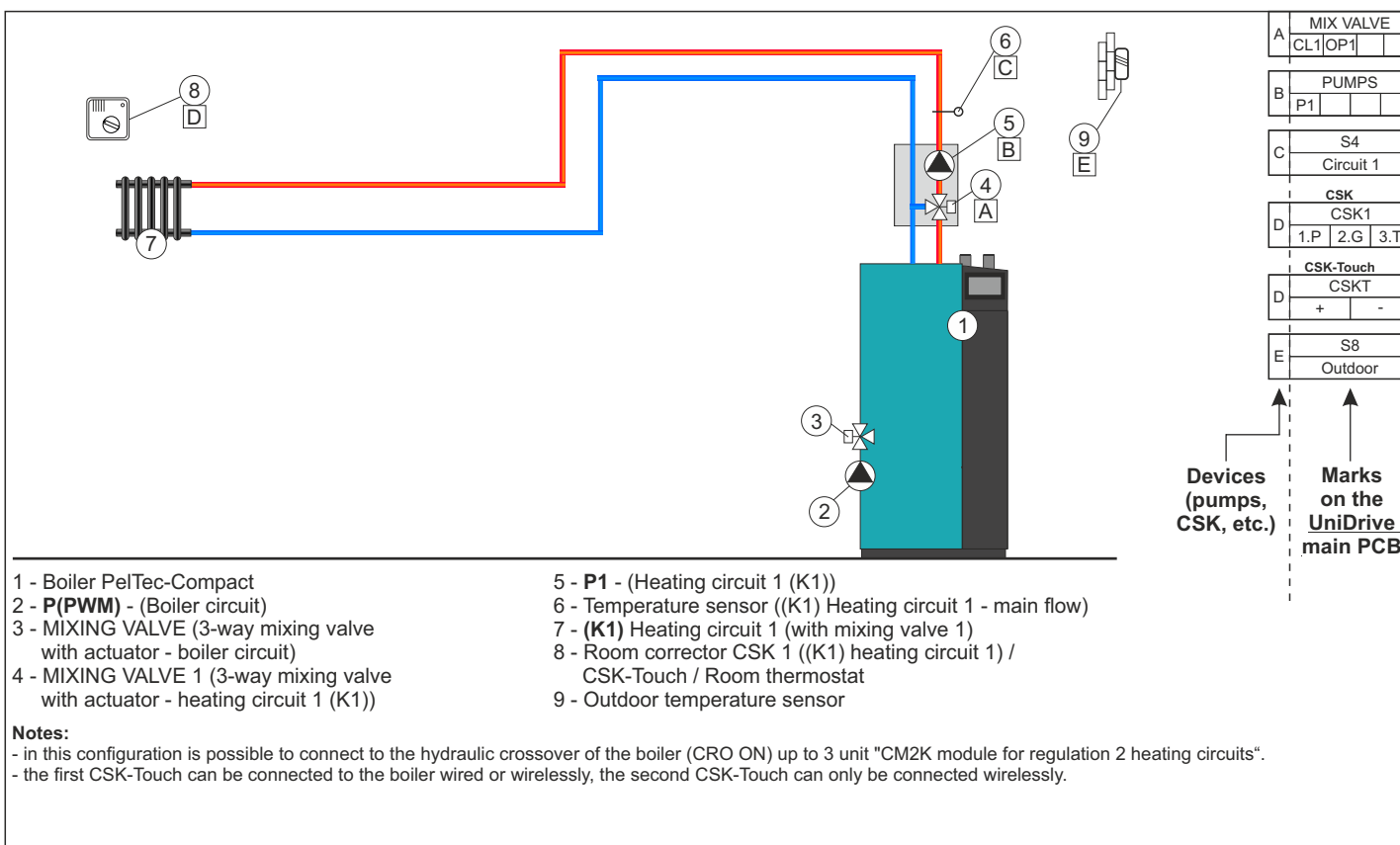

	CSK		
D	CSK1		
	1.P	2.G	3.T

Example of the position of CSK on the main PCB UniDrive.



Main PCB: UniDrive



4.2.2. CONFIGURATION / SCHEME

CONFIGURATION 1

CRO ON

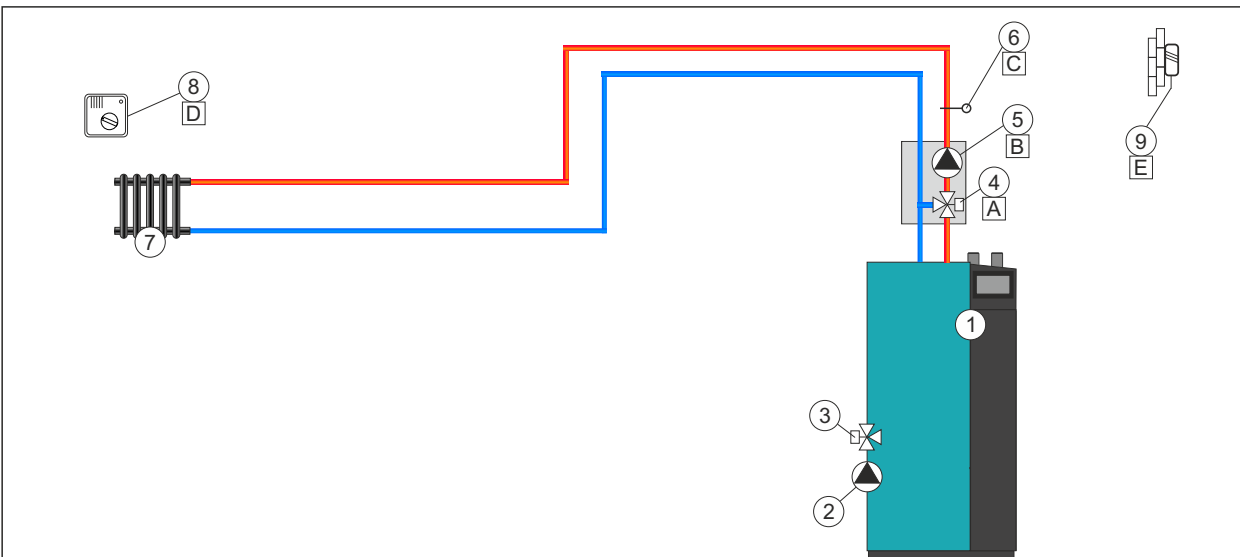

A	MIX VALVE
	CL1 OP1
B	PUMPS
	P1
C	S4
	Circuit 1
	CSK
D	CSK1
	1.P 2.G 3.T
	CSK-Touch
D	CSKT
	+ -
E	S8
	Outdoor

- 1 - Boiler PelTec-Compact
- 2 - P(PWM) - (Boiler circuit)
- 3 - MIXING VALVE (3-way mixing valve with actuator - boiler circuit)
- 4 - MIXING VALVE 1 (3-way mixing valve with actuator - heating circuit 1 (K1))
- 5 - P1 - (Heating circuit 1 (K1))
- 6 - Temperature sensor ((K1) Heating circuit 1 - main flow)
- 7 - (K1) Heating circuit 1 (with mixing valve 1)
- 8 - Room corrector CSK 1 ((K1) heating circuit 1) / CSK-Touch / Room thermostat
- 9 - Outdoor temperature sensor

Notes:
 - in this configuration is possible to connect to the hydraulic crossover of the boiler (CRO ON) up to 3 unit "CM2K module for regulation 2 heating circuits".
 - the first CSK-Touch can be connected to the boiler wired or wirelessly, the second CSK-Touch can only be connected wirelessly.

CONFIGURATION 2

CRO ON

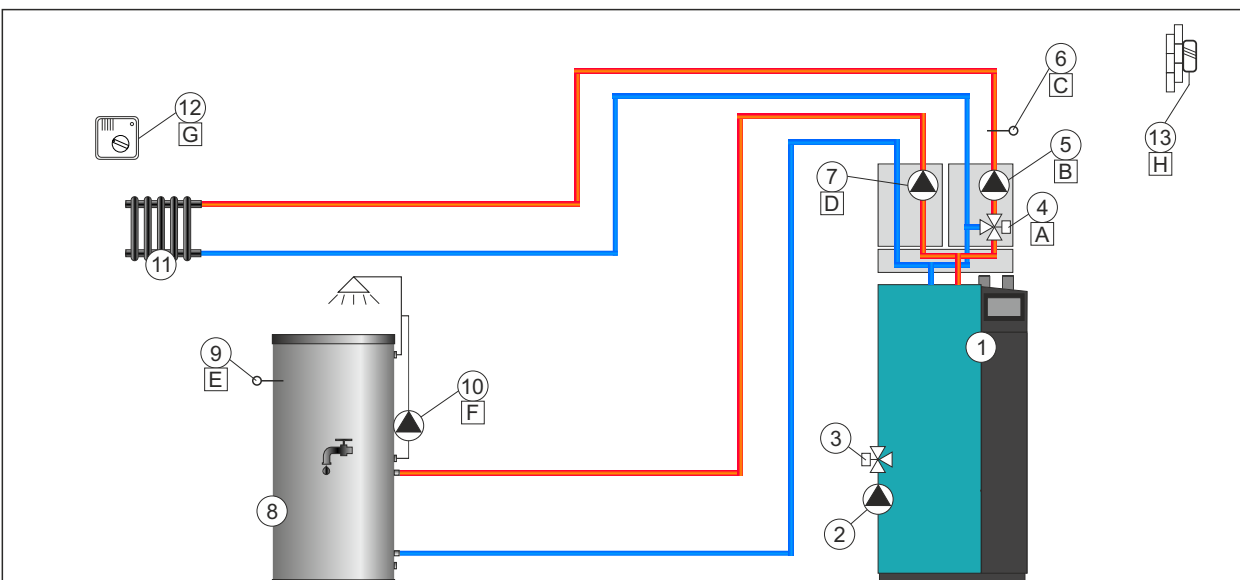

A	MIX VALVE
	CL1 OP1
B	PUMPS
	P1
C	S4
	Circuit 1
D	PUMPS
	P2
E	S6
	Circuit 2
F	PUMPS
	P3
	CSK
G	CSK1
	1.P 2.G 3.T
	CSK-Touch
G	CSKT
	+ -
H	S8
	Outdoor

- 1 - Boiler PelTec-Compact
- 2 - P(PWM) - (Boiler circuit)
- 3 - MIXING VALVE (3-way mixing valve with actuator - boiler circuit)
- 4 - MIXING VALVE 1 (3-way mixing valve with actuator - heating circuit 1 (K1))
- 5 - P1 - (Heating circuit 1 (K1))
- 6 - Temperature sensor ((K1) Heating circuit 1 - main flow)
- 7 - P2 - DHW (Heating circuit 2 (K2))
- 8 - (K2) Heating circuit 2 (DHW)
- 9 - Temperature sensor DHW ((K2) Heating circuit 2)
- 10 - P3 - Recirculation DHW (Heating circuit 2 (K2))
- 11 - (K1) Heating circuit 1 (with mixing valve 1)
- 12 - Room corrector CSK 1 ((K1) heating circuit 1) / CSK-Touch / Room thermostat
- 13 - Outdoor temperature sensor

Notes:
 - in this configuration is possible to connect to the hydraulic crossover of the boiler (CRO ON) up to 3 unit "CM2K module for regulation 2 heating circuits".
 - the first CSK-Touch can be connected to the boiler wired or wirelessly, the second CSK-Touch can only be connected wirelessly.

CONFIGURATION 3

CRO ON

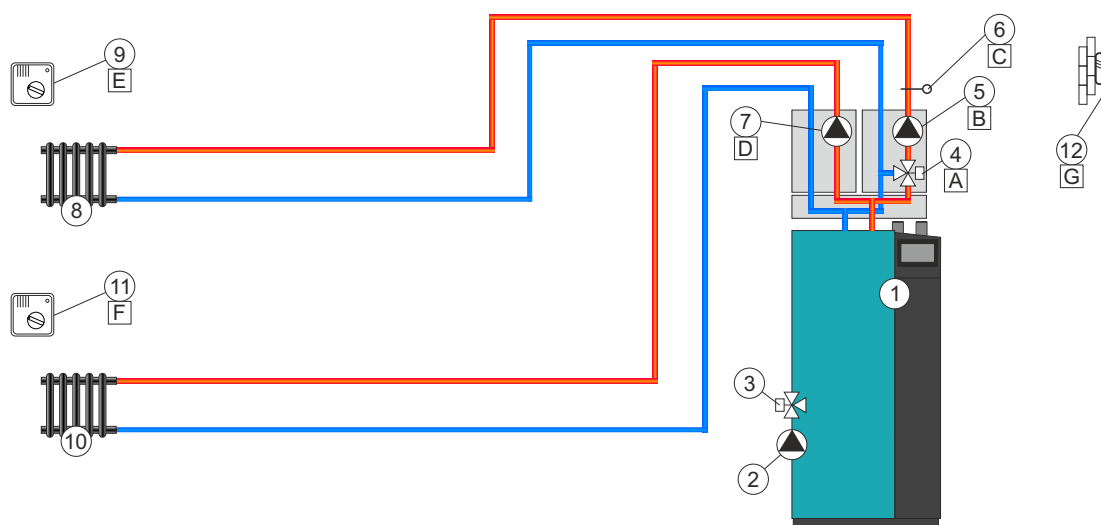

A	MIX VALVE
	CL1 OP1
B	PUMPS
	P1
C	S4
	Circuit 1
D	PUMPS
	P2
CSK 1	
E	CSK1
	1.P 2.G 3.T
CSK-Touch 1	
E	CSKT
	+ -
CSK 2	
F	CSK1
	1.P 2.G 3.T
S8	
G	Outdoor

- 1 - Boiler PelTec-Compact
- 2 - P(PWM) - (Boiler circuit)
- 3 - MIXING VALVE (3-way mixing valve with actuator - boiler circuit)
- 4 - MIXING VALVE 1 (3-way mixing valve with actuator - heating circuit 1 (K1))
- 5 - P1 - (Heating circuit 1 (K1))
- 6 - Temperature sensor ((K1) Heating circuit 1 - main flow)
- 7 - P2 - (heating circuit 2 (K2))
- 8 - (K1) Heating circuit 1 (with mixing valve 1)
- 9 - Room corrector CSK 1 ((K1) heating circuit 1) / CSK-Touch / Room thermostat
- 10 - (K2) Heating circuit 2 - (direct circuit)
- 11 - Room corrector CSK 2 ((K2) heating circuit 2) / CSK-Touch / Room thermostat
- 12 - Outdoor temperature sensor

Notes:
 - in this configuration is possible to connect to the hydraulic crossover of the boiler (CRO ON) up to 3 unit "CM2K module for regulation 2 heating circuits".
 - the first CSK-Touch can be connected to the boiler wired or wirelessly, the second CSK-Touch can only be connected wirelessly.

CONFIGURATION 4

CRO OFF

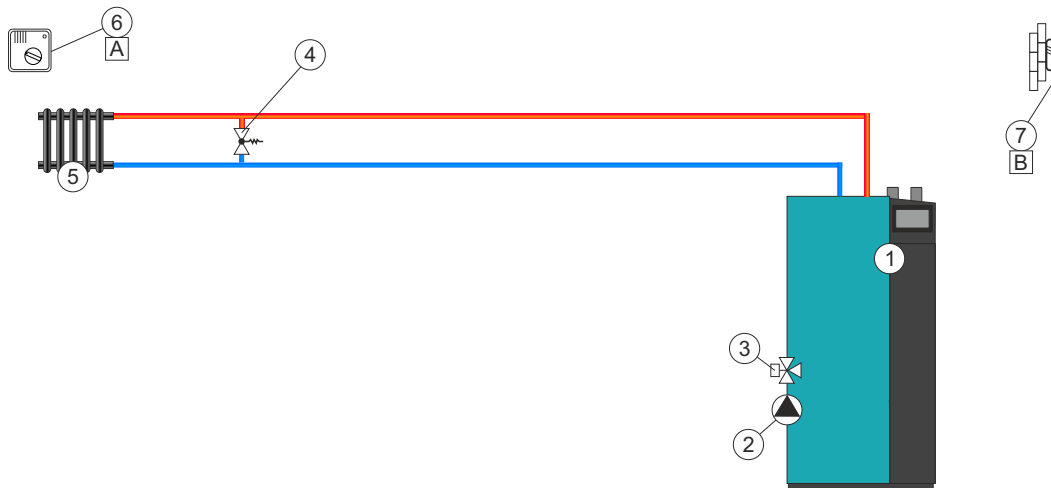

CSK	
A	CSK1
	1.P 2.G 3.T
CSK-Touch	
A	CSKT
	+ -
S8	
B	Outdoor

- 1 - Boiler PelTec-Compact
- 2 - P(PWM) - (Boiler circuit)
- 3 - MIXING VALVE (3-way mixing valve with actuator - boiler circuit)
- 4 - Bypass valve (Δp)
- 5 - (K1) Heating circuit 1 - (direct circuit)
- 6 - Room corrector CSK 1 ((K1) heating circuit 1) / CSK-Touch / Room thermostat
- 7 - Outdoor temperature sensor

Notes:
 - in this configuration, it is not possible to connect the "CM2K module for regulation 2 heating circuits".
 - the first CSK-Touch can be connected to the boiler wired or wirelessly, the second CSK-Touch can only be connected wirelessly.

CONFIGURATION 5

CRO OFF

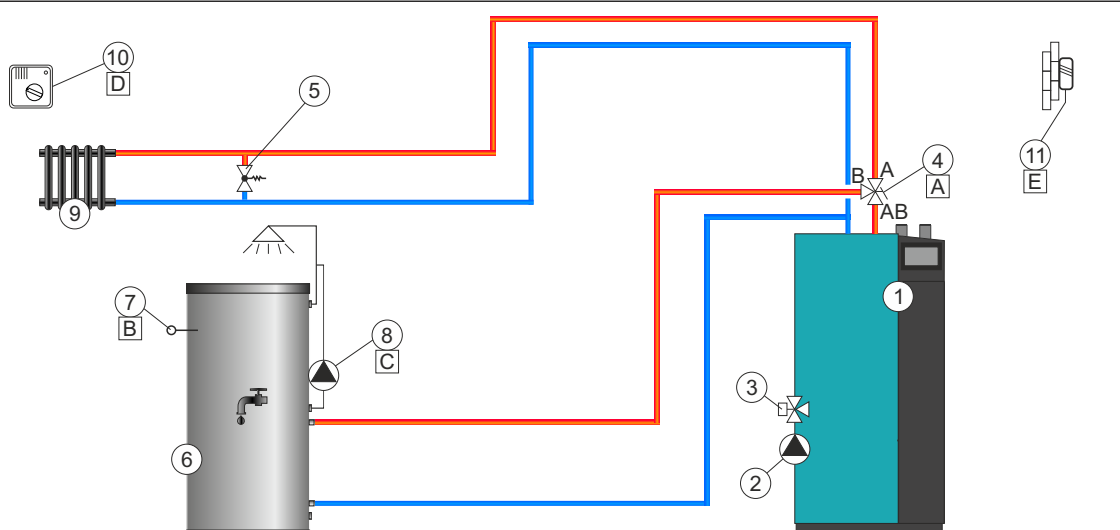

A	PUMPS	
P1		
B	S6 Circuit 2	
C	PUMPS	
P2		
CSK		
D	CSK1	
1.P	2.G	3.T
CSK-Touch		
D	CSKT	
+	-	
E	S8 Outdoor	

- 1 - Boiler PelTec-Compact
- 2 - P(PWM) - (Boiler circuit)
- 3 - MIXING VALVE (3-way mixing valve with actuator - boiler circuit)
- 4 - P1 - Diverting valve
- 5 - Bypass valve (Δp)
- 6 - (K2) Heating circuit 2 (DHW)

- 7 - Temperature sensor DHW ((K2) Heating circuit 2)
- 8 - P2 - Recirculation DHW (Heating circuit 2 (K2))
- 9 - (K1) Heating circuit 1 - (direct circuit)
- 10 - Room corrector CSK 1 ((K1) heating circuit 1) / CSK-Touch / Room thermostat
- 11 - Outdoor temperature sensor

Notes:

- in this configuration, it is not possible to connect the "CM2K module for regulation 2 heating circuits".
- the first CSK-Touch can be connected to the boiler wired or wirelessly, the second CSK-Touch can only be connected wirelessly.

CONFIGURATION 6

CRO ON

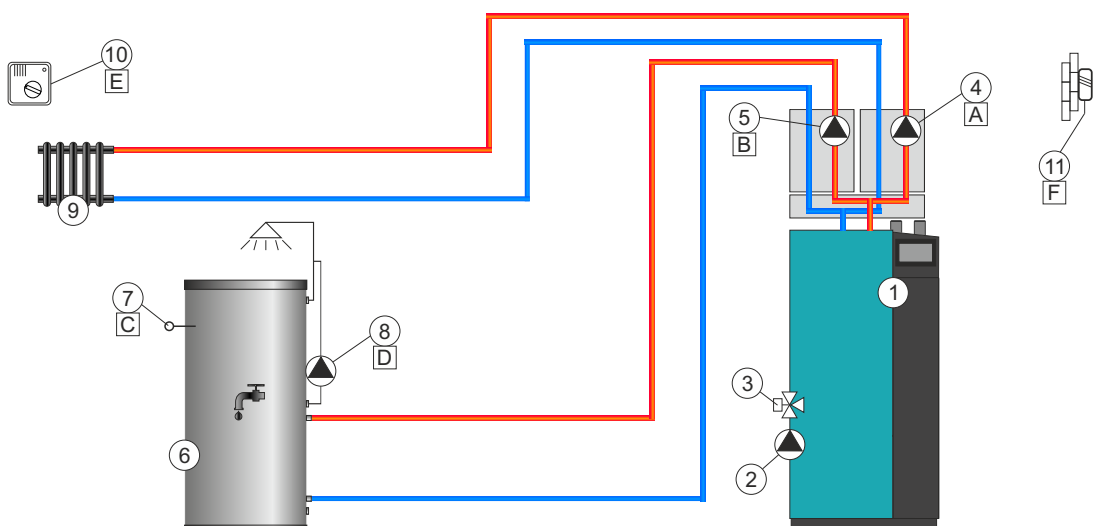

A	PUMPS	
P1		
B	PUMPS	
P2		
C	S6 Circuit 2	
D	PUMPS	
P3		
CSK		
E	CSK1	
1.P	2.G	3.T
CSK-Touch		
E	CSKT	
+	-	
F	S8 Outdoor	

- 1 - Boiler PelTec-Compact
- 2 - P(PWM) - (Boiler circuit)
- 3 - MIXING VALVE (3-way mixing valve with actuator - boiler circuit)
- 4 - P1 - (Heating circuit 1 (K1))
- 5 - P2 - DHW (Heating circuit 2 (K2))
- 6 - (K2) Heating circuit 2 (DHW)

- 7 - Temperature sensor DHW ((K2) Heating circuit 2)
- 8 - P3 - Recirculation DHW (Heating circuit 2 (K2))
- 9 - (K1) Heating circuit 1 - (direct circuit)
- 10 - Room corrector CSK 1 ((K1) heating circuit 1) / CSK-Touch / Room thermostat
- 11 - Outdoor temperature sensor

Notes:

- in this configuration is possible to connect to the hydraulic crossover of the boiler (CRO ON) up to 3 unit "CM2K module for regulation 2 heating circuits".
- the first CSK-Touch can be connected to the boiler wired or wirelessly, the second CSK-Touch can only be connected wirelessly.

CONFIGURATION 7

CRO ON

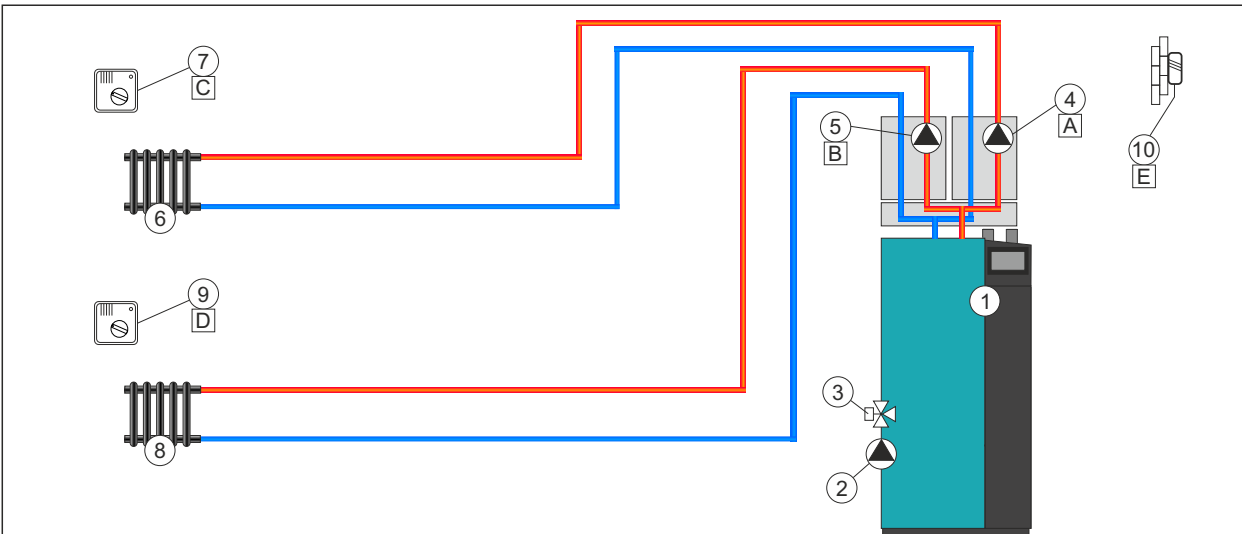

A	PUMPS	
P1		
B	PUMPS	
P2		
CSK 1		
C	CSK1	
1.P	2.G	3.T
CSK-Touch 1		
C	CSKT	
+	-	
CSK 2		
D	CSK1	
1.P	2.G	3.T
E	S8	
	Outdoor	

- 1 - Boiler PelTec-Compact
- 2 - **P(PWM)** - (Boiler circuit)
- 3 - MIXING VALVE (3-way mixing valve with actuator - boiler circuit)
- 4 - **P1** - (Heating circuit 1 (K1))
- 5 - **P2** - (Heating circuit 2 (K2))
- 6 - **(K1)** Heating circuit 1 - (direct circuit)

- 7 - Room corrector CSK 1 ((K1) heating circuit 1) / CSK-Touch / Room thermostat
- 8 - **(K2)** Heating circuit 2 - (direct circuit)
- 9 - Room corrector CSK 2 ((K2) heating circuit 2) / CSK-Touch / Room thermostat
- 10 - Outdoor temperature sensor

Notes:

- in this configuration is possible to connect to the hydraulic crossover of the boiler (CRO ON) up to 3 unit "CM2K module for regulation 2 heating circuits".
- the first CSK-Touch can be connected to the boiler wired or wirelessly, the second CSK-Touch can only be connected wirelessly.

CONFIGURATION 8

CRO OFF

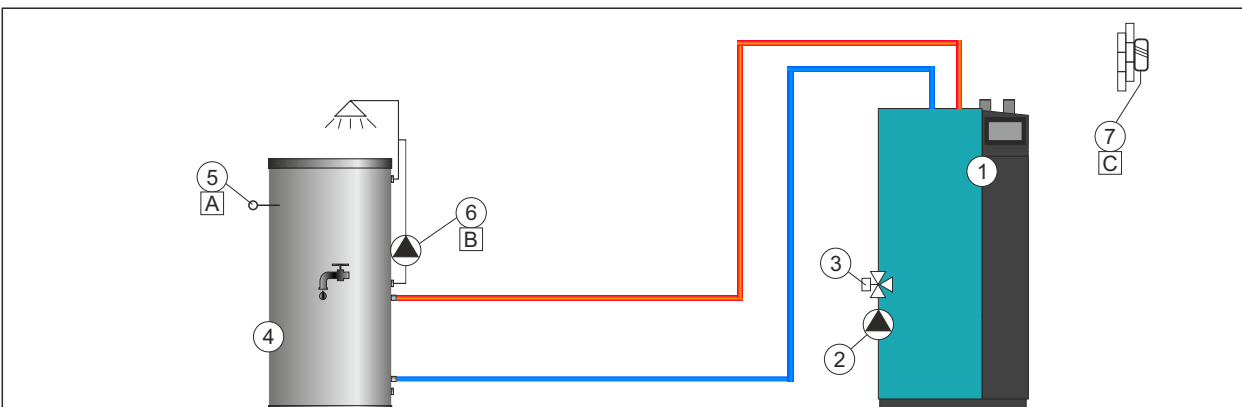

A	S4
	Circuit 1
B	PUMPS
P1	
C	S8
	Outdoor

- 1 - Boiler PelTec-Compact
- 2 - **P(PWM)** - (Boiler circuit)
- 3 - MIXING VALVE (3-way mixing valve with actuator - boiler circuit)
- 4 - **(K1)** Heating circuit 1 (DHW)

- 5 - Temperature sensor DHW ((K1) Heating circuit 1)
- 6 - **P1** - Recirculation DHW (Heating circuit 1 (K1))
- 7 - Outdoor temperature sensor

Notes:

- in this configuration, it is not possible to connect the "CM2K module for regulation 2 heating circuits".
- in this configuration, it is not possible to connect CSK-Touch (additional equipment).

CONFIGURATION 9

CRO ON

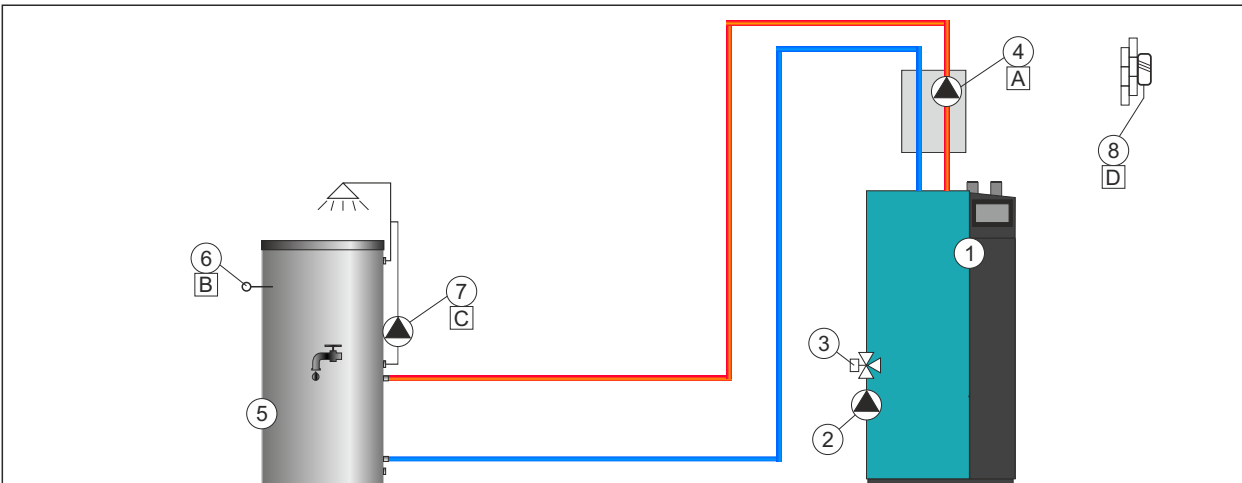

A	PUMPS			
	P1			
B	S4			
	Circuit 1			
C	PUMPS			
	P2			
D	S8			
	Outdoor			
CSK-Touch				
*	CSKT			
		+		-

- 1 - Boiler PelTec-Compact
- 2 - **P(PWM)** - (Boiler circuit)
- 3 - MIXING VALVE (3-way mixing valve with actuator - boiler circuit)
- 4 - **P1** - DHW (Heating circuit 1 (K1))
- 5 - **(K1)** Heating circuit 1 (DHW)
- 6 - Temperature sensor DHW ((K1) Heating circuit 1)
- 7 - **P2** - Recirculation DHW (Heating circuit 1 (K1))
- 8 - Outdoor temperature sensor

Notes:
 - in this configuration is possible to connect to the hydraulic crossover of the boiler (CRO ON) up to 3 unit "CM2K module for regulation 2 heating circuits".
 * in this configuration is possible to connect CSK-Touch (additional equipment) only if CM2K is installed.

CONFIGURATION 10

CRO ON

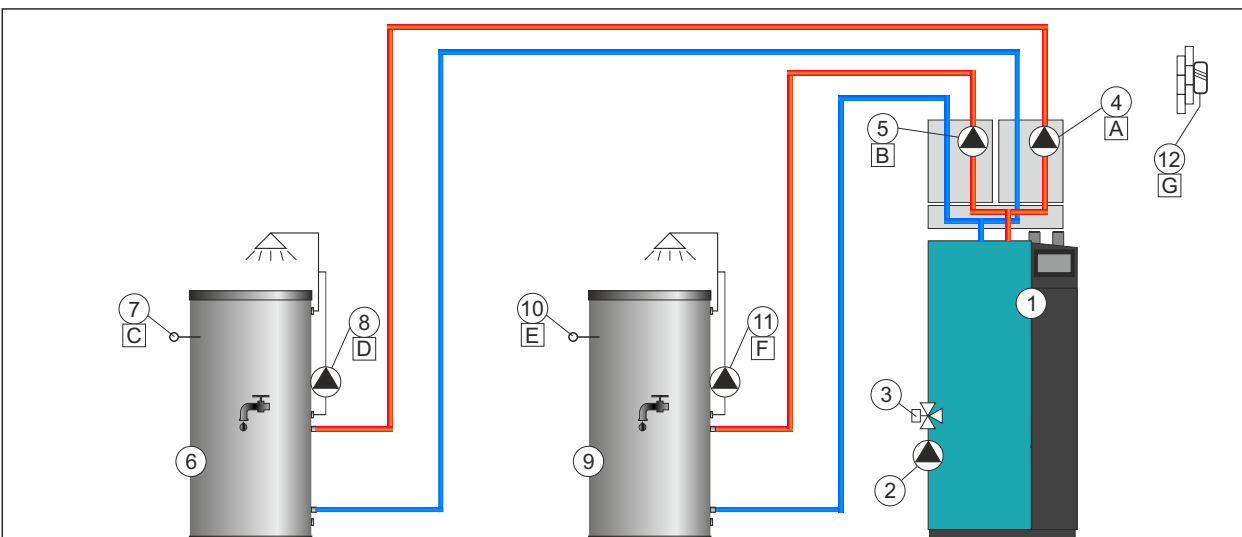

A	PUMPS			
	P1			
B	PUMPS			
	P2			
C	S4			
	Circuit 1			
D	PUMPS			
	P3			
E	S6			
	Circuit 2			
F	PUMPS			
	P4			
G	S8			
	Outdoor			
CSK-Touch				
*	CSKT			
		+		-

- 1 - Boiler PelTec-Compact
- 2 - **P(PWM)** - (Boiler circuit)
- 3 - MIXING VALVE (3-way mixing valve with actuator - boiler circuit)
- 4 - **P1** - DHW (Heating circuit 1 (K1))
- 5 - **P2** - DHW (Heating circuit 2 (K2))
- 6 - **(K1)** Heating circuit 1 (DHW)
- 7 - Temperature sensor DHW ((K1) Heating circuit 1)
- 8 - **P3** - Recirculation DHW (Heating circuit 1 (K1))
- 9 - **(K2)** Heating circuit 2 (DHW)
- 10 - Temperature sensor DHW ((K2) Heating circuit 2)
- 11 - **P4** - Recirculation DHW (Heating circuit 2 (K2))
- 12 - Outdoor temperature sensor

Notes:
 - in this configuration is possible to connect to the hydraulic crossover of the boiler (CRO ON) up to 3 unit "CM2K module for regulation 2 heating circuits".
 * in this configuration is possible to connect CSK-Touch (additional equipment) only if CM2K is installed.

CONFIGURATION 11

CRO OFF

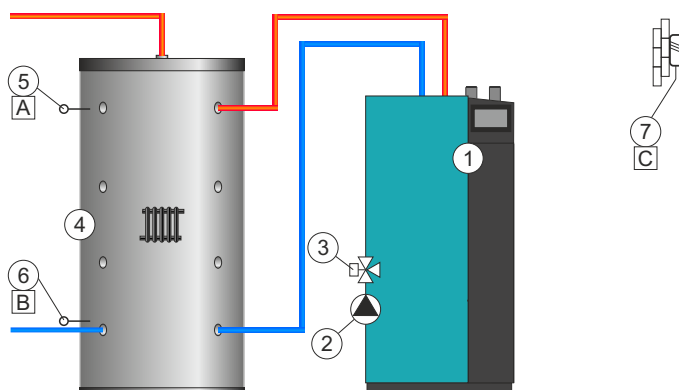

A	S5
	Buffer up
B	S3
	Buffer down
C	S8
	Outdoor
CSK-Touch	
CSKT	
*	+ -

- 1 - Boiler PelTec-Compact
- 2 - **P(PWM)** - (Boiler circuit)
- 3 - MIXING VALVE (3-way mixing valve with actuator - boiler circuit)

- 4 - "CAS" accumulation (buffer) tank
- 5 - Temperature sensor (UP) - accumulation (buffer) tank
- 6 - Temperature sensor (DOWN) - accumulation (buffer) tank
- 7 - Outdoor temperature sensor

Notes:

- in this configuration is possible to connect to the accumulation (buffer) tank up to 3 unit "CM2K module for regulation 2 heating circuits".
- in this configuration, it is possible to connect 8 boilers in a cascade using the CMNET module (all boilers are connected to the same accumulation (buffer) tank/s)
- * in this configuration is possible to connect CSK-Touch (additional equipment) only if CM2K is installed.

CONFIGURATION 12

CRO OFF

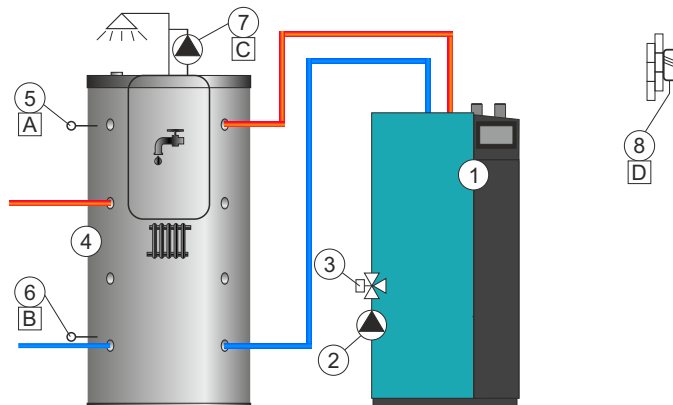

A	S5
	Buffer up
B	S3
	Buffer down
C	PUMPS
	P1
D	S8
	Outdoor
CSK-Touch	
CSKT	
*	+ -

- 1 - Boiler PelTec-Compact
- 2 - **P(PWM)** - (Boiler circuit)
- 3 - MIXING VALVE (3-way mixing valve with actuator - boiler circuit)
- 4 - "CAS-B" accumulation (buffer) tank

- 5 - Temperature sensor (UP) - accumulation (buffer) tank
- 6 - Temperature sensor (DOWN) - accumulation (buffer) tank
- 7 - **P1** - Recirculation DHW
- 8 - Outdoor temperature sensor

Notes:

- in this configuration is possible to connect to the accumulation (buffer) tank up to 3 unit "CM2K module for regulation 2 heating circuits".
- * in this configuration is possible to connect CSK-Touch (additional equipment) only if CM2K is installed.

CONFIGURATION 13

CRO OFF

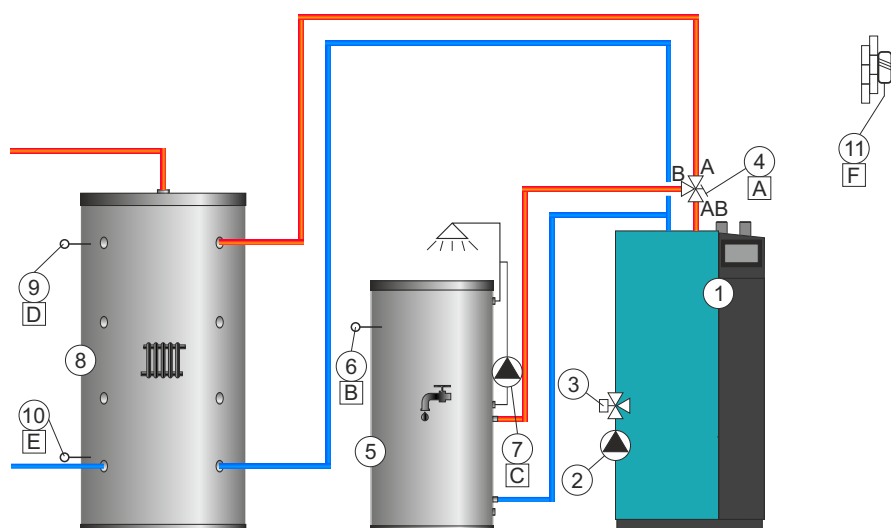

- 1 - Boiler PelTec-Compact
- 2 - P(PWM) - (Boiler circuit)
- 3 - MIXING VALVE (3-way mixing valve with actuator - boiler circuit)
- 4 - P1 - Diverting valve
- 5 - (K1) Heating circuit 1 (DHW)

- 6 - Temperature sensor DHW ((K1) Heating circuit 1)
- 7 - P2 - Recirculation DHW (Heating circuit 1 (K1))
- 8 - "CAS" accumulation (buffer) tank
- 9 - Temperature sensor (UP) - accumulation (buffer) tank
- 10 - Temperature sensor (DOWN) - accumulation (buffer) tank
- 11 - Outdoor temperature sensor

Notes:

- in this configuration is possible to connect to the accumulation (buffer) tank up to 3 unit "CM2K module for regulation 2 heating circuits".
 * in this configuration is possible to connect CSK-Touch (additional equipment) only if CM2K is installed.

A	PUMPS
P1	
B	S4 Circuit 1
C	PUMPS
P2	
D	S5 Buffer up
E	S3 Buffer down
F	S8 Outdoor
CSK-Touch	
CSKT	
+	-

CONFIGURATION 14

CRO OFF

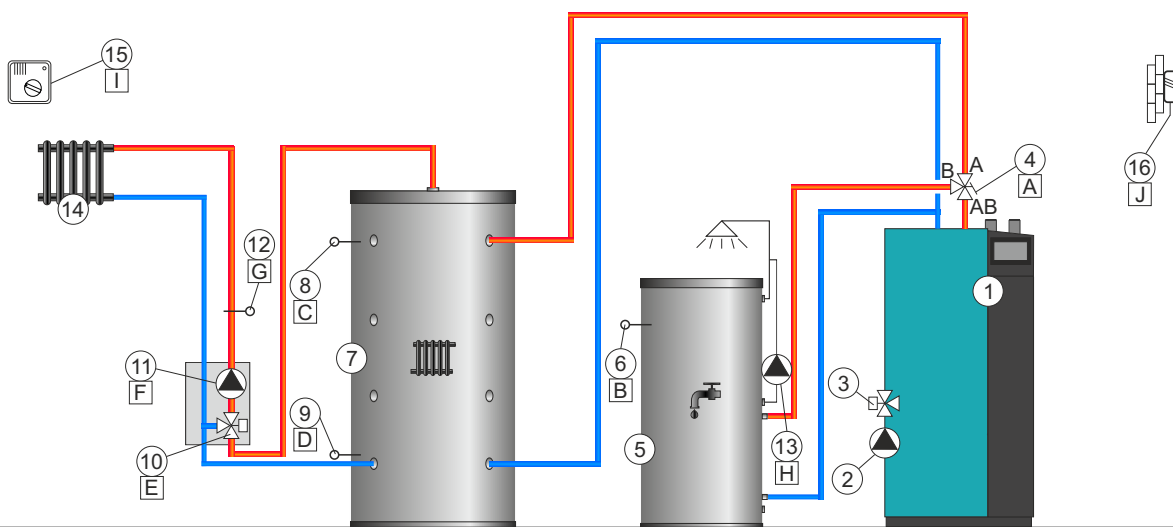

- 1 - Boiler PelTec-Compact
- 2 - P(PWM) - (Boiler circuit)
- 3 - MIXING VALVE (3-way mixing valve with actuator - boiler circuit)
- 4 - P1 - Diverting valve
- 5 - (K2) Heating circuit 2 (DHW)
- 6 - Temperature sensor DHW ((K2) Heating circuit 2)
- 7 - "CAS" accumulation (buffer) tank
- 8 - Temperature sensor (UP) - accumulation (buffer) tank
- 9 - Temperature sensor (DOWN) - accumulation (buffer) tank

- 10 - MIXING VALVE 1 (3-way mixing valve with actuator - heating circuit 1 (K1))
- 11 - P2 - (Heating circuit 1 (K1))
- 12 - Temperature sensor ((K1) Heating circuit 1 - main flow)
- 13 - P3 - Recirculation DHW (Heating circuit 2 (K2))
- 14 - (K1) Heating circuit 1 (with mixing valve 1)
- 15 - Room corrector CSK 1 ((K1) heating circuit 1) / CSK-Touch / Room thermostat
- 16 - Outdoor temperature sensor

Notes:

- in this configuration is possible to connect to the accumulation (buffer) tank up to 3 unit "CM2K module for regulation 2 heating circuits".
 - the first CSK-Touch can be connected to the boiler wired or wirelessly, the second CSK-Touch can only be connected wirelessly.

A	PUMPS
P1	
B	S6 Circuit 2
C	S5 Buffer up
D	S3 Buffer down
E	MIX VALVE CL1OP1
F	PUMPS
P2	
G	S4 Circuit 1
H	PUMPS
P3	
CSK	
CSK1	
I	1.P 2.G 3.T
CSK-Touch	
CSKT	
+	-
J	S8 Outdoor

CONFIGURATION 15

CRO OFF

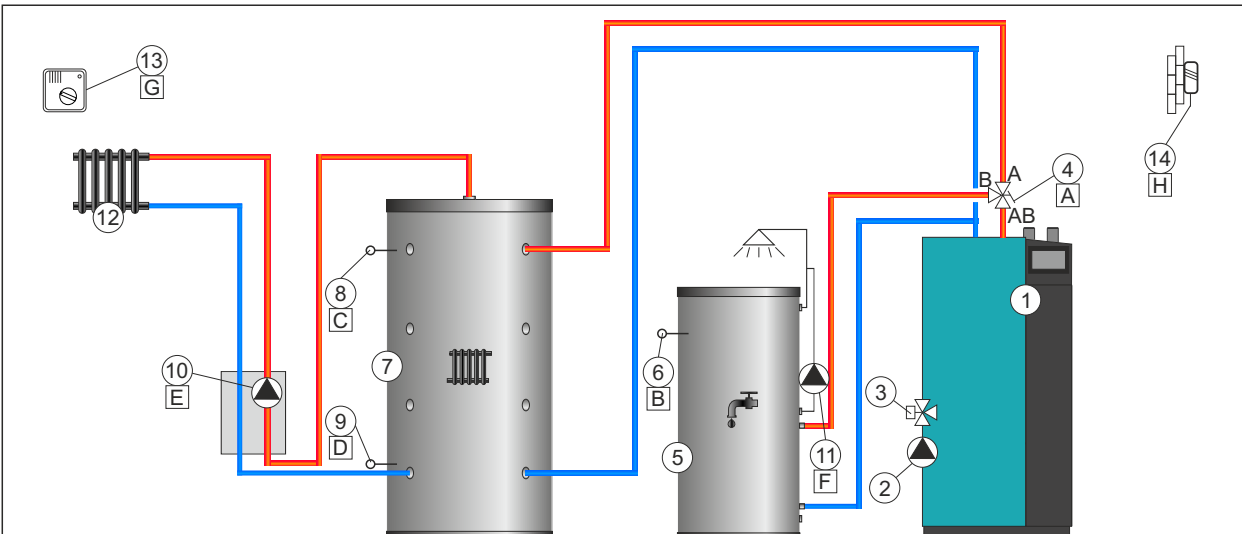

- 1 - Boiler PelTec-Compact
- 2 - P(PWM) - (Boiler circuit)
- 3 - MIXING VALVE (3-way mixing valve with actuator - boiler circuit)
- 4 - P1 - Diverting valve
- 5 - (K2) Heating circuit 2 (DHW)
- 6 - Temperature sensor DHW ((K2) Heating circuit 2)
- 7 - "CAS" accumulation (buffer) tank

- 8 - Temperature sensor (UP) - accumulation (buffer) tank
- 9 - Temperature sensor (DOWN) - accumulation (buffer) tank
- 10 - P2 - (Heating circuit 1 (K1))
- 11 - P3 - Recirculation DHW (Heating circuit 2 (K2))
- 12 - (K1) Heating circuit 1 - (direct circuit)
- 13 - Room corrector CSK 1 ((K1) heating circuit 1) / CSK-Touch / Room thermostat
- 14 - Outdoor temperature sensor

Notes:

- in this configuration is possible to connect to the accumulation (buffer) tank up to 3 unit "CM2K module for regulation 2 heating circuits".
- the first CSK-Touch can be connected to the boiler wired or wirelessly, the second CSK-Touch can only be connected wirelessly.

A	PUMPS
P1	
B	S6 Circuit 2
C	S5 Buffer up
D	S3 Buffer down
E	PUMPS
P2	
F	PUMPS
P3	
CSK	
CSK1	
G	1.P 2.G 3.T
CSK-Touch	
CSKT	
G	+ -
H	S8 Outdoor

CONFIGURATION 16

CRO OFF

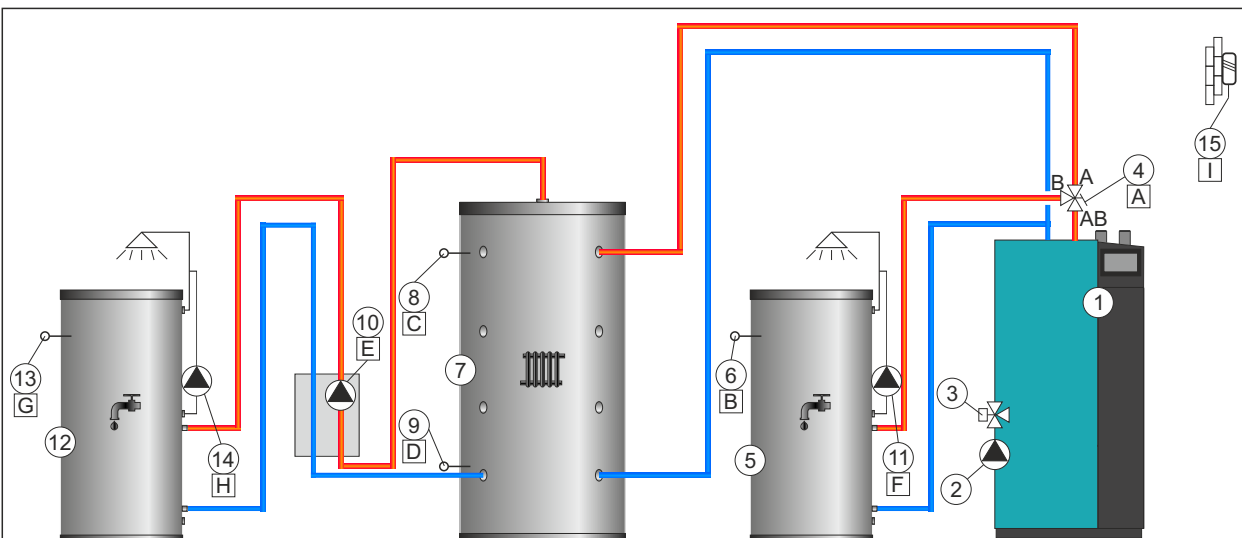

- 1 - Boiler PelTec-Compact
- 2 - P(PWM) - (Boiler circuit)
- 3 - MIXING VALVE (3-way mixing valve with actuator - boiler circuit)
- 4 - P1 - Diverting valve
- 5 - (K1) Heating circuit 1 (DHW)
- 6 - Temperature sensor DHW ((K1) Heating circuit 1)
- 7 - "CAS" accumulation (buffer) tank

- 8 - Temperature sensor (UP) - accumulation (buffer) tank
- 9 - Temperature sensor (DOWN) - accumulation (buffer) tank
- 10 - P2 - (Heating circuit 2 (K2))
- 11 - P3 - Recirculation DHW (Heating circuit 1 (K1))
- 12 - (K2) Heating circuit 2 (DHW)
- 13 - Temperature sensor DHW ((K2) Heating circuit 2)
- 14 - P4 - Recirculation DHW (Heating circuit 2 (K2))
- 15 - Outdoor temperature sensor

Notes:

- in this configuration is possible to connect to the accumulation (buffer) tank up to 3 unit "CM2K module for regulation 2 heating circuits".
- * in this configuration is possible to connect CSK-Touch (additional equipment) only if CM2K is installed.

A	PUMPS
P1	
B	S4 Circuit 1
C	S5 Buffer up
D	S3 Buffer down
E	PUMPS
P2	
F	PUMPS
P3	
G	S6 Circuit 2
H	PUMPS
P4	
I	S8 Outdoor
CSK-Touch	
CSKT	
*	+ -

CONFIGURATION 17

CRO ON

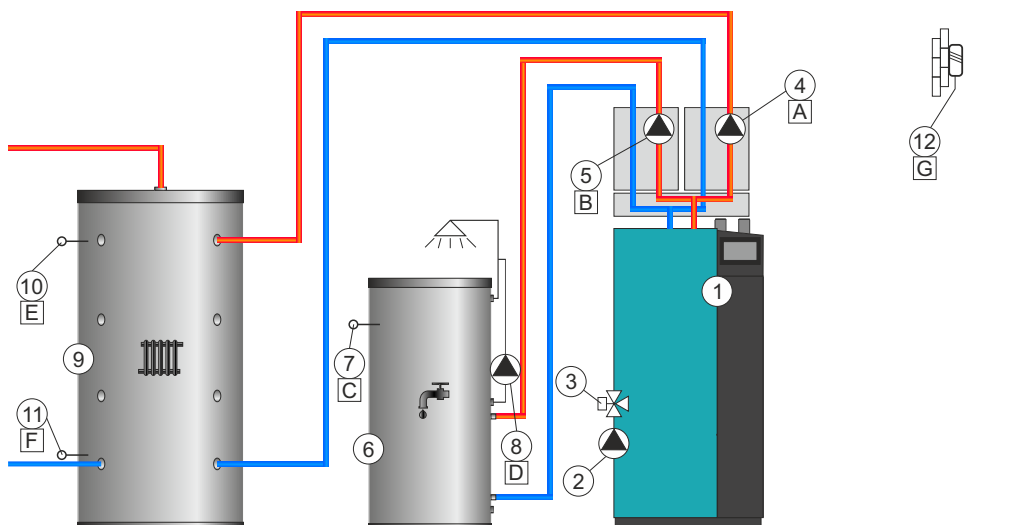

A	PUMPS			
	P1			
B	PUMPS			
	P2			
C	S4			Circuit 1
D	PUMPS			
	P3			
E	S5			Buffer up
F	S3			Buffer down
G	S8			Outdoor
CSK-Touch				
CSKT				
*	+			-

- 1 - Boiler PelTec-Compact
- 2 - P(PWM) - (Boiler circuit)
- 3 - MIXING VALVE (3-way mixing valve with actuator - boiler circuit)
- 4 - P1 - BUF (accumulation (buffer) tank)
- 5 - P2 - DHW (Heating circuit 1 (K1))
- 6 - (K1) Heating circuit 1 (DHW)
- 7 - Temperature sensor DHW ((K1) Heating circuit 1)
- 8 - P3 - Recirculation DHW (Heating circuit 1 (K1))
- 9 - "CAS" accumulation (buffer) tank
- 10 - Temperature sensor (UP) - accumulation (buffer) tank
- 11 - Temperature sensor (DOWN) - accumulation (buffer) tank
- 12 - Outdoor temperature sensor

Notes:

- in this configuration is possible to connect to the accumulation (buffer) tank or to the hydraulic crossover of the boiler (CRO ON) up to 3 unit "CM2K module for regulation 2 heating circuits".
 * in this configuration is possible to connect CSK-Touch (additional equipment) only if CM2K is installed.

CONFIGURATION 18

CRO ON

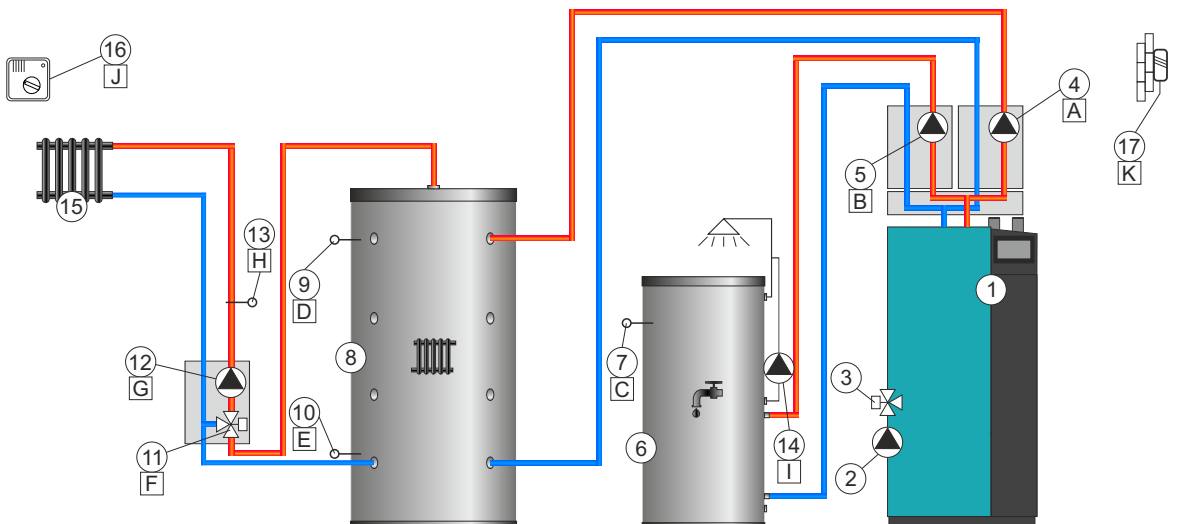

A	PUMPS			
	P1			
B	PUMPS			
	P2			
C	S6			Circuit 2
D	S5			Buffer up
E	S3			Buffer down
F	MIX VALVE			CL1 OP1
G	PUMPS			
	P3			
H	S4			Circuit 1
I	PUMPS			
	P4			
CSK				
CSK1				
J	1.P	2.G	3.T	
CSK-Touch				
CSKT				
J	+			-
K	S8			Outdoor

- 1 - Boiler PelTec-Compact
- 2 - P(PWM) - (Boiler circuit)
- 3 - MIXING VALVE (3-way mixing valve with actuator - boiler circuit)
- 4 - P1 - BUF (accumulation (buffer) tank)
- 5 - P2 - DHW (Heating circuit 2 (K2))
- 6 - (K2) Heating circuit 2 (DHW)
- 7 - Temperature sensor DHW ((K2) Heating circuit 2)
- 8 - "CAS" accumulation (buffer) tank
- 9 - Temperature sensor (UP) - accumulation (buffer) tank
- 10 - Temperature sensor (DOWN) - accumulation (buffer) tank
- 11 - MIXING VALVE 1 (3-way mixing valve with actuator - heating circuit 1 (K1))
- 12 - P3 - (Heating circuit 1 (K1))
- 13 - Temperature sensor ((K1) Heating circuit 1 - main flow)
- 14 - P4 - Recirculation DHW (Heating circuit 2 (K2))
- 15 - (K1) Heating circuit 1 (with mixing valve 1)
- 16 - Room corrector CSK 1 ((K1) heating circuit 1) / CSK-Touch / Room thermostat
- 17 - Outdoor temperature sensor

Notes:

- in this configuration is possible to connect to the accumulation (buffer) tank or to the hydraulic crossover of the boiler (CRO ON) up to 3 unit "CM2K module for regulation 2 heating circuits".
 - the first CSK-Touch can be connected to the boiler wired or wirelessly, the second CSK-Touch can only be connected wirelessly.

CONFIGURATION 19

CRO ON

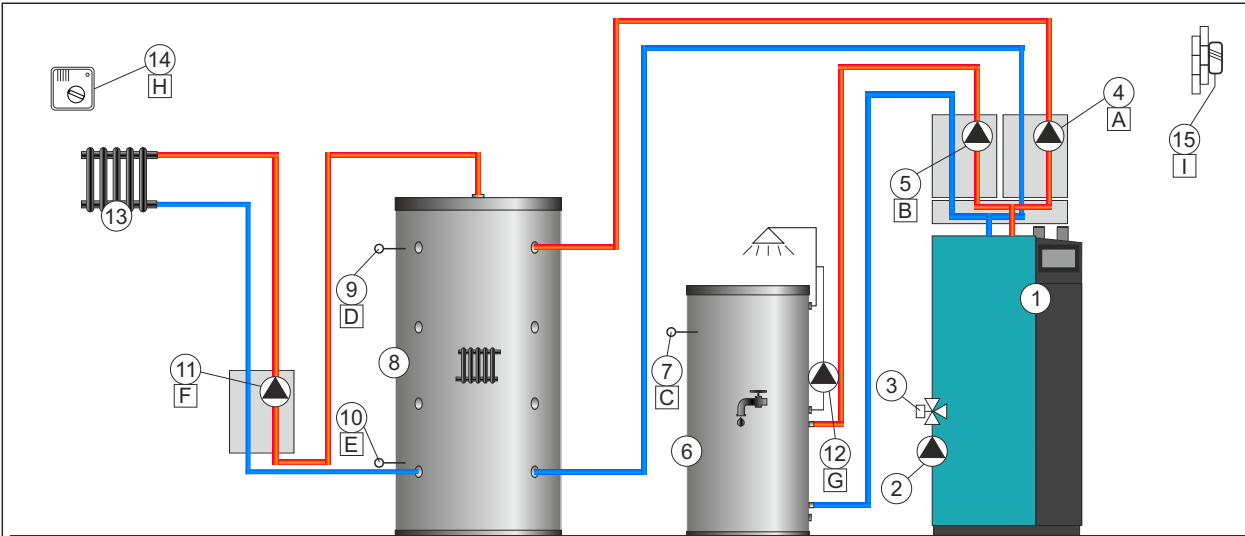

- 1 - Boiler PelTec-Compact
- 2 - P(PWM) - (Boiler circuit)
- 3 - MIXING VALVE (3-way mixing valve with actuator - boiler circuit)
- 4 - P1 - BUF (accumulation (buffer) tank)
- 5 - P2 - DHW (Heating circuit 2 (K2))
- 6 - (K2) Heating circuit 2 (DHW)
- 7 - Temperature sensor DHW ((K2) Heating circuit 2)
- 8 - "CAS" accumulation (buffer) tank
- 9 - Temperature sensor (UP) - accumulation (buffer) tank
- 10 - Temperature sensor (DOWN) - accumulation (buffer) tank
- 11 - P3 - (Heating circuit 1 (K1))
- 12 - P4 - Recirculation DHW (Heating circuit 2 (K2))
- 13 - (K1) Heating circuit 1 - (direct circuit)
- 14 - Room corrector CSK 1 ((K1) heating circuit 1) / CSK-Touch / Room thermostat
- 15 - Outdoor temperature sensor

Notes:

- in this configuration is possible to connect to the accumulation (buffer) tank or to the hydraulic crossover of the boiler (CRO ON) up to 3 unit "CM2K module for regulation 2 heating circuits".
- the first CSK-Touch can be connected to the boiler wired or wirelessly, the second CSK-Touch can only be connected wirelessly.

A	PUMPS			
	P1			
B	PUMPS			
	P2			
C	S6			Circuit 2
D	S5			Buffer up
E	S3			Buffer down
F	PUMPS			
	P3			
G	PUMPS			
	P4			
CSK				
H	CSK1			
	1.P	2.G	3.T	
CSK-Touch				
H	CSKT			
	+		-	
I	S8			Outdoor

CONFIGURATION 20

CRO ON

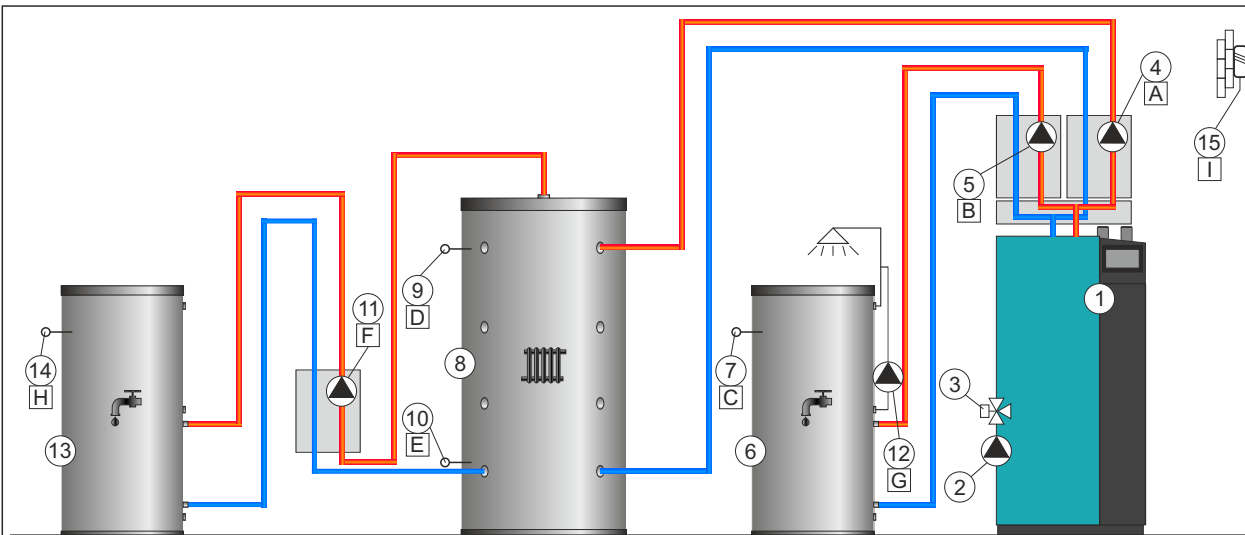

- 1 - Boiler PelTec-Compact
- 2 - P(PWM) - (Boiler circuit)
- 3 - MIXING VALVE (3-way mixing valve with actuator - boiler circuit)
- 4 - P1 - BUF (accumulation (buffer) tank)
- 5 - P2 - DHW (Heating circuit 1 (K1))
- 6 - (K1) Heating circuit 1 (DHW)
- 7 - Temperature sensor DHW ((K1) Heating circuit 1)
- 8 - "CAS" accumulation (buffer) tank
- 9 - Temperature sensor (UP) - accumulation (buffer) tank
- 10 - Temperature sensor (DOWN) - accumulation (buffer) tank
- 11 - P3 - (Heating circuit 2 (K2))
- 12 - P4 - Recirculation DHW (Heating circuit 1 (K1))
- 13 - (K2) Heating circuit 2 (DHW)
- 14 - Temperature sensor DHW ((K2) Heating circuit 2)
- 15 - Outdoor temperature sensor

Notes:

- in this configuration is possible to connect to the accumulation (buffer) tank or to the hydraulic crossover of the boiler (CRO ON) up to 3 unit "CM2K module for regulation 2 heating circuits".
- * in this configuration is possible to connect CSK-Touch (additional equipment) only if CM2K is installed.

A	PUMPS			
	P1			
B	PUMPS			
	P2			
C	S4			Circuit 1
D	S5			Buffer up
E	S3			Buffer down
F	PUMPS			
	P3			
G	PUMPS			
	P4			
H	S6			Circuit 2
I	S8			Outdoor
CSK-Touch				
*	CSKT			
	+		-	

CONFIGURATION 21

CRO ON

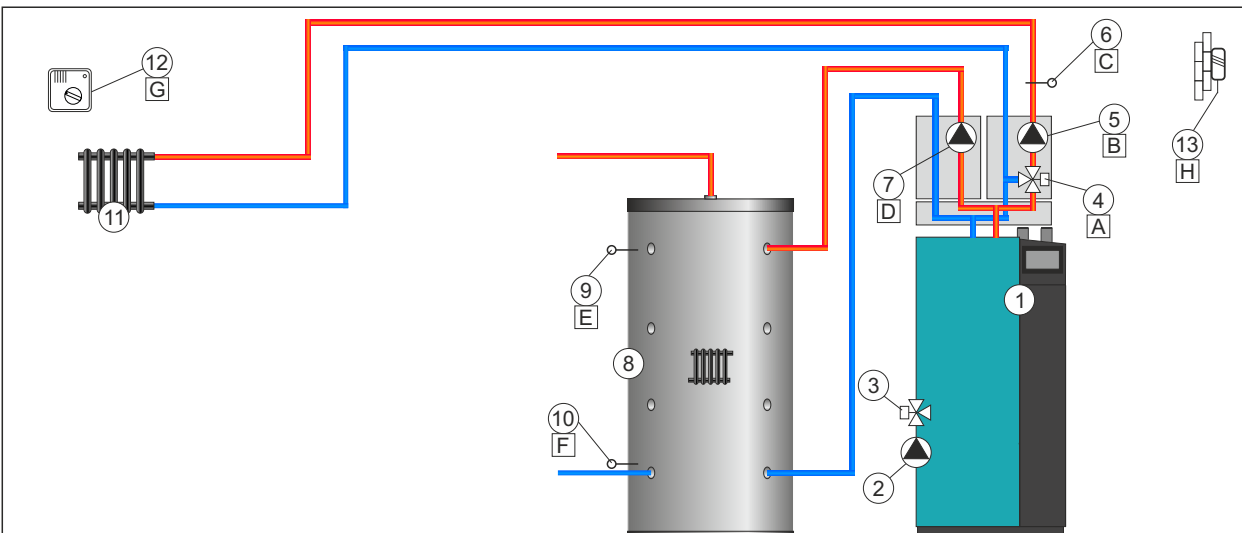

A	MIX VALVE
	CL1 OP1
B	PUMPS
	P1
C	S4
	Circuit 1
D	PUMPS
	P2
E	S5
	Buffer up
F	S3
	Buffer down
CSK	
G	CSK1
	1.P 2.G 3.T
CSK-Touch	
G	CSKT
	+ -
H	S8
	Outdoor

- 1 - Boiler PelTec-Compact
- 2 - P(PWM) - (Boiler circuit)
- 3 - MIXING VALVE (3-way mixing valve with actuator - boiler circuit)
- 4 - MIXING VALVE 1 (3-way mixing valve with actuator - heating circuit 1 (K1))
- 5 - P1 - (Heating circuit 1 (K1))
- 6 - Temperature sensor ((K1) Heating circuit 1 - main flow)
- 7 - P2 - BUF (accumulation (buffer) tank)
- 8 - "CAS" accumulation (buffer) tank
- 9 - Temperature sensor (UP) - accumulation (buffer) tank
- 10 - Temperature sensor (DOWN) - accumulation (buffer) tank
- 11 - (K1) Heating circuit 1 (with mixing valve 1)
- 12 - Room corrector CSK 1 ((K1) heating circuit 1) / CSK-Touch / Room thermostat
- 13 - Outdoor temperature sensor

Notes:
 - in this configuration is possible to connect to the accumulation (buffer) tank or to the hydraulic crossover of the boiler (CRO ON) up to 3 unit "CM2K module for regulation 2 heating circuits".
 - the first CSK-Touch can be connected to the boiler wired or wirelessly, the second CSK-Touch can only be connected wirelessly.

CONFIGURATION 22

CRO ON

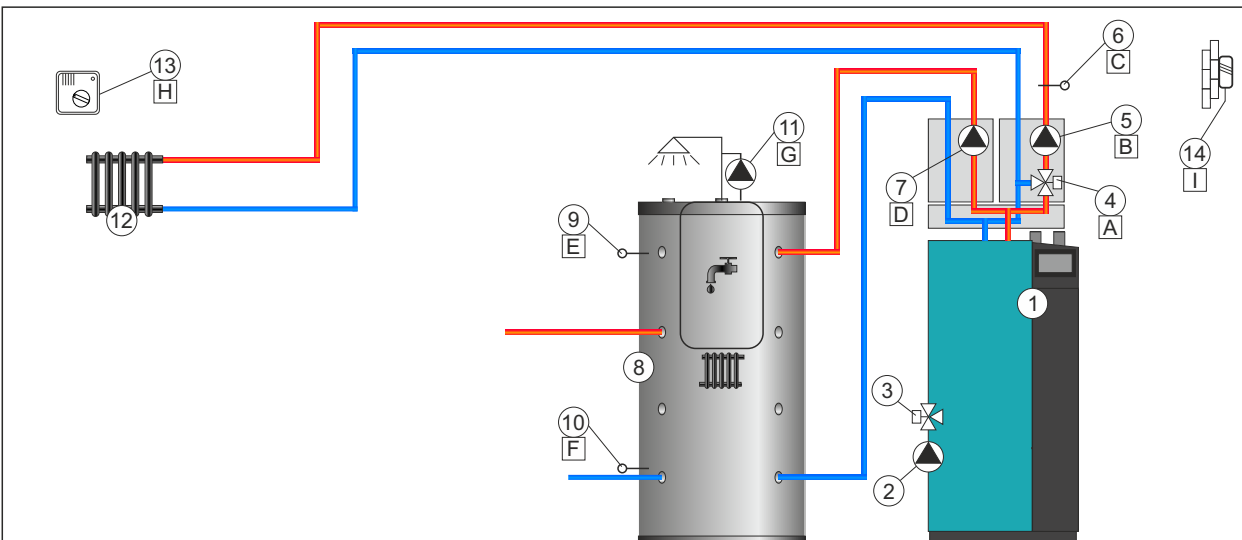

A	MIX VALVE
	CL1 OP1
B	PUMPS
	P1
C	S4
	Circuit 1
D	PUMPS
	P2
E	S5
	Buffer up
F	S3
	Buffer down
G	PUMPS
	P3
CSK	
H	CSK1
	1.P 2.G 3.T
CSK-Touch	
H	CSKT
	+ -
I	S8
	Outdoor

- 1 - Boiler PelTec-Compact
- 2 - P(PWM) - (Boiler circuit)
- 3 - MIXING VALVE (3-way mixing valve with actuator - boiler circuit)
- 4 - MIXING VALVE 1 (3-way mixing valve with actuator - heating circuit 1 (K1))
- 5 - P1 - (Heating circuit 1 (K1))
- 6 - Temperature sensor ((K1) Heating circuit 1 - main flow)
- 7 - P2 - BUF (accumulation (buffer) tank)
- 8 - "CAS-B" accumulation (buffer) tank
- 9 - Temperature sensor (UP) - accumulation (buffer) tank
- 10 - Temperature sensor (DOWN) - accumulation (buffer) tank
- 11 - P3 - Recirculation DHW
- 12 - (K1) Heating circuit 1 (with mixing valve 1)
- 13 - Room corrector CSK 1 ((K1) heating circuit 1) / CSK-Touch / Room thermostat
- 14 - Outdoor temperature sensor

Notes:
 - in this configuration is possible to connect to the accumulation (buffer) tank or to the hydraulic crossover of the boiler (CRO ON) up to 3 unit "CM2K module for regulation 2 heating circuits".
 - the first CSK-Touch can be connected to the boiler wired or wirelessly, the second CSK-Touch can only be connected wirelessly.

CONFIGURATION 23

CRO ON

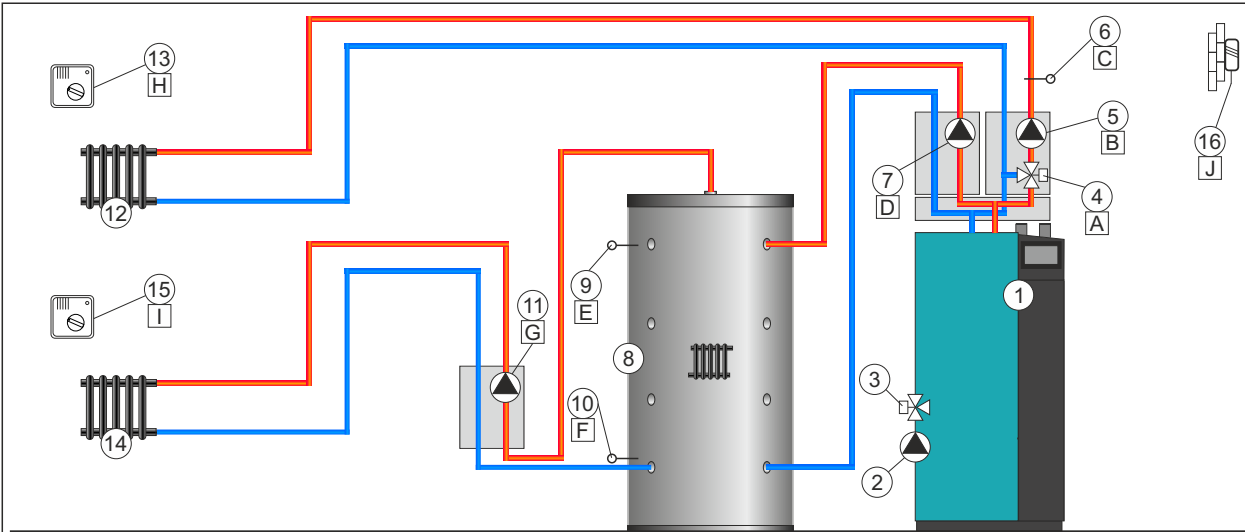

- 1 - Boiler PelTec-Compact
- 2 - **P(PWM)** - (Boiler circuit)
- 3 - MIXING VALVE (3-way mixing valve with actuator - boiler circuit)
- 4 - MIXING VALVE 1 (3-way mixing valve with actuator - heating circuit 1 (K1))
- 5 - **P1** - (Heating circuit 1 (K1))
- 6 - Temperature sensor ((K1) Heating circuit 1 - main flow)
- 7 - **P2** - BUF (accumulation (buffer) tank)
- 8 - "CAS" accumulation (buffer) tank
- 9 - Temperature sensor (UP) - accumulation (buffer) tank
- 10 - Temperature sensor (DOWN) - accumulation (buffer) tank
- 11 - **P3** - (Heating circuit 2 (K2))
- 12 - (**K1**) Heating circuit 1 (with mixing valve 1)
- 13 - Room corrector CSK 1 ((K1) heating circuit 1) / CSK-Touch / Room thermostat
- 14 - (**K2**) Heating circuit 2 - (direct circuit)
- 15 - Room corrector CSK 2 ((K2) heating circuit 2) / CSK-Touch / Room thermostat
- 16 - Outdoor temperature sensor

Notes:

- in this configuration is possible to connect to the accumulation (buffer) tank or to the hydraulic crossover of the boiler (CRO ON) up to 3 unit "CM2K module for regulation 2 heating circuits".
- the first CSK-Touch can be connected to the boiler wired or wirelessly, the second CSK-Touch can only be connected wirelessly.

A	MIX VALVE	CL1 OP1	
B	PUMPS	P1	
C	S4	Circuit 1	
D	PUMPS	P2	
E	S5	Buffer up	
F	S3	Buffer down	
G	PUMPS		P3
CSK 1			
H	CSK1	1.P	2.G 3.T
CSK-Touch 1			
H	CSKT	+	-
CSK 2			
I	CSK1	1.P	2.G 3.T
J	S8	Outdoor	

CONFIGURATION 24

CRO ON

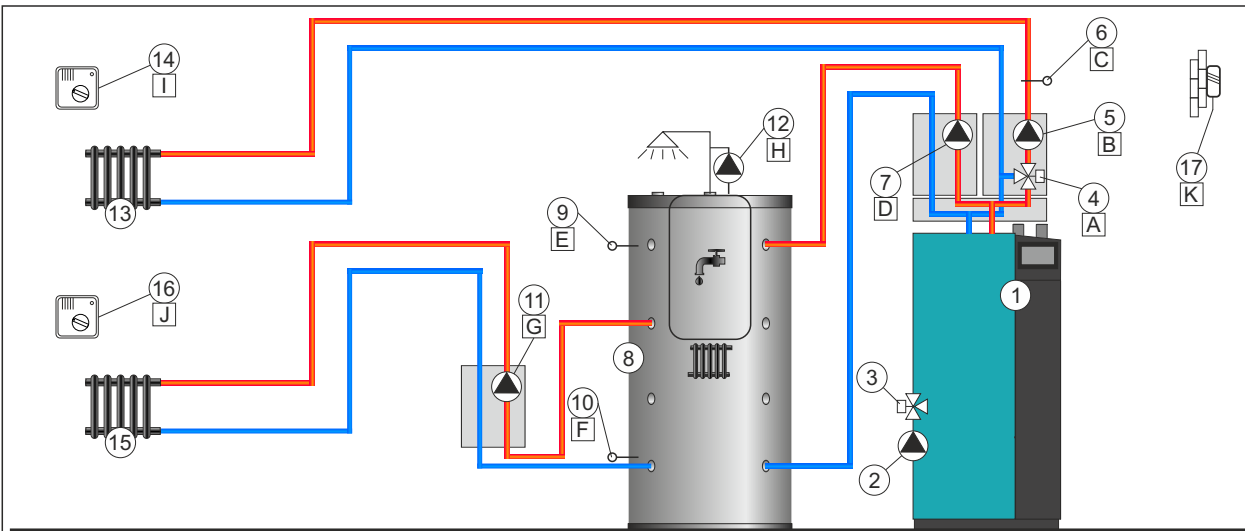

- 1 - Boiler PelTec-Compact
- 2 - **P(PWM)** - (Boiler circuit)
- 3 - MIXING VALVE (3-way mixing valve with actuator - boiler circuit)
- 4 - MIXING VALVE 1 (3-way mixing valve with actuator - heating circuit 1 (K1))
- 5 - **P1** - (Heating circuit 1 (K1))
- 6 - Temperature sensor ((K1) Heating circuit 1 - main flow)
- 7 - **P2** - BUF (accumulation (buffer) tank)
- 8 - "CAS-B" accumulation (buffer) tank
- 9 - Temperature sensor (UP) - accumulation (buffer) tank
- 10 - Temperature sensor (DOWN) - accumulation (buffer) tank
- 11 - **P3** - (Heating circuit 2 (K2))
- 12 - **P4** - Recirculation DHW
- 13 - (**K1**) Heating circuit 1 (with mixing valve 1)
- 14 - Room corrector CSK 1 ((K1) heating circuit 1) / CSK-Touch / Room thermostat
- 15 - (**K2**) Heating circuit 2 - (direct circuit)
- 16 - Room corrector CSK 2 ((K2) heating circuit 2) / CSK-Touch / Room thermostat
- 17 - Outdoor temperature sensor

Notes:

- in this configuration is possible to connect to the accumulation (buffer) tank or to the hydraulic crossover of the boiler (CRO ON) up to 3 unit "CM2K module for regulation 2 heating circuits".
- the first CSK-Touch can be connected to the boiler wired or wirelessly, the second CSK-Touch can only be connected wirelessly.

A	MIX VALVE	CL1 OP1	
B	PUMPS	P1	
C	S4	Circuit 1	
D	PUMPS	P2	
E	S5	Buffer up	
F	S3	Buffer down	
G	PUMPS		P3
H	PUMPS		P4
CSK 1			
I	CSK1	1.P	2.G 3.T
CSK-Touch 1			
I	CSKT	+	-
CSK 2			
J	CSK1	1.P	2.G 3.T
K	S8	Outdoor	

CONFIGURATION 25

CRO ON

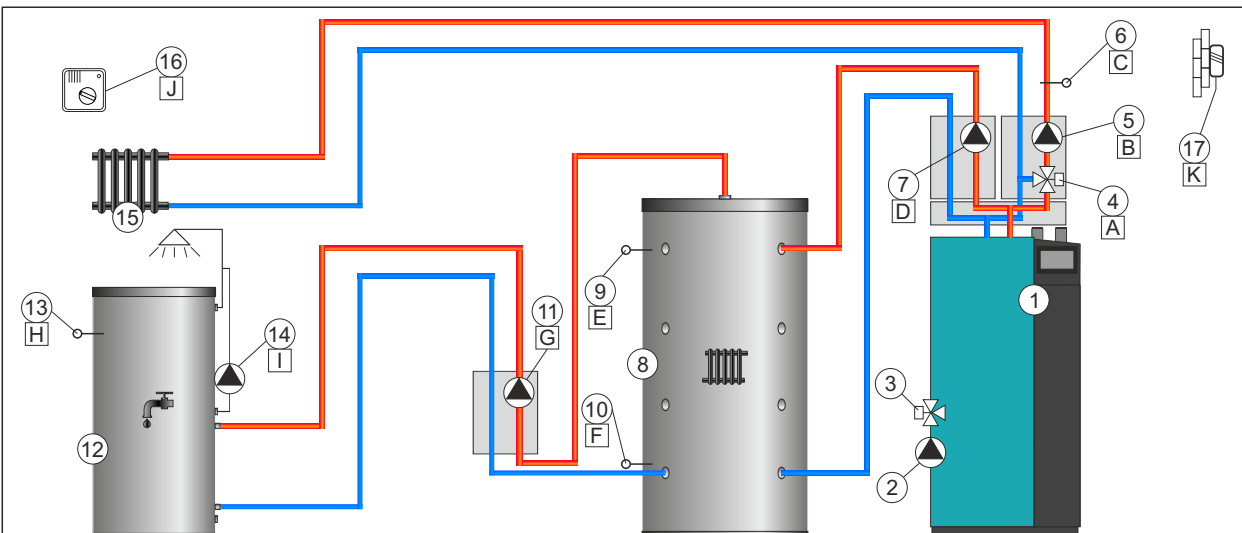

- 1 - Boiler PelTec-Compact
- 2 - P(PWM) - (Boiler circuit)
- 3 - MIXING VALVE (3-way mixing valve with actuator - boiler circuit)
- 4 - MIXING VALVE 1 (3-way mixing valve with actuator - heating circuit 1 (K1))
- 5 - P1 - (Heating circuit 1 (K1))
- 6 - Temperature sensor ((K1) Heating circuit 1 - main flow)
- 7 - P2 - BUF (accumulation (buffer) tank)
- 8 - "CAS" accumulation (buffer) tank

- 9 - Temperature sensor (UP) - accumulation (buffer) tank
- 10 - Temperature sensor (DOWN) - accumulation (buffer) tank
- 11 - P3 - DHW (Heating circuit 2 (K2))
- 12 - (K2) Heating circuit 2 (DHW)
- 13 - Temperature sensor DHW ((K2) Heating circuit 2)
- 14 - P4 - Recirculation DHW (Heating circuit 2 (K2))
- 15 - (K1) Heating circuit 1 (with mixing valve 1)
- 16 - Room corrector CSK 1 ((K1) heating circuit 1) / CSK-Touch / Room thermostat
- 17 - Outdoor temperature sensor

Notes:

- in this configuration is possible to connect to the accumulation (buffer) tank or to the hydraulic crossover of the boiler (CRO ON) up to 3 unit "CM2K module for regulation 2 heating circuits".
- the first CSK-Touch can be connected to the boiler wired or wirelessly, the second CSK-Touch can only be connected wirelessly.

A	MIX VALVE
	CL1 OP1
B	PUMPS
	P1
C	S4
	Circuit 1
D	PUMPS
	P2
E	S5
	Buffer up
F	S3
	Buffer down
G	PUMPS
	P3
H	S6
	Circuit 2
I	PUMPS
	P4
CSK	
J	CSK1
	1.P 2.G 3.T
CSK-Touch	
J	CSKT
	+ -
K	S8
	Outdoor

CONFIGURATION 26

CRO ON

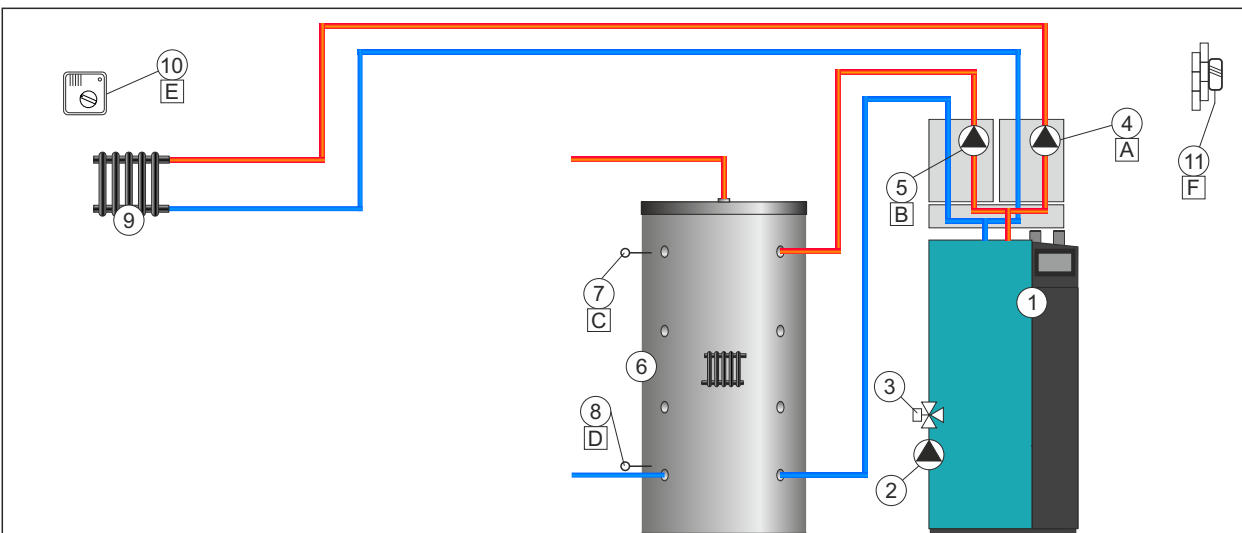

- 1 - Boiler PelTec-Compact
- 2 - P(PWM) - (Boiler circuit)
- 3 - MIXING VALVE (3-way mixing valve with actuator - boiler circuit)
- 4 - P1 - (Heating circuit 1 (K1))
- 5 - P2 - BUF (accumulation (buffer) tank)
- 6 - "CAS" accumulation (buffer) tank

- 7 - Temperature sensor (UP) - accumulation (buffer) tank
- 8 - Temperature sensor (DOWN) - accumulation (buffer) tank
- 9 - (K1) Heating circuit 1 - (direct circuit)
- 10 - Room corrector CSK 1 ((K1) heating circuit 1) / CSK-Touch / Room thermostat
- 11 - Outdoor temperature sensor

Notes:

- in this configuration is possible to connect to the accumulation (buffer) tank or to the hydraulic crossover of the boiler (CRO ON) up to 3 unit "CM2K module for regulation 2 heating circuits".
- the first CSK-Touch can be connected to the boiler wired or wirelessly, the second CSK-Touch can only be connected wirelessly.

A	PUMPS
	P1
B	PUMPS
	P2
C	S5
	Buffer up
D	S3
	Buffer down
CSK	
E	CSK1
	1.P 2.G 3.T
CSK-Touch	
E	CSKT
	+ -
F	S8
	Outdoor

CONFIGURATION 27

CRO ON

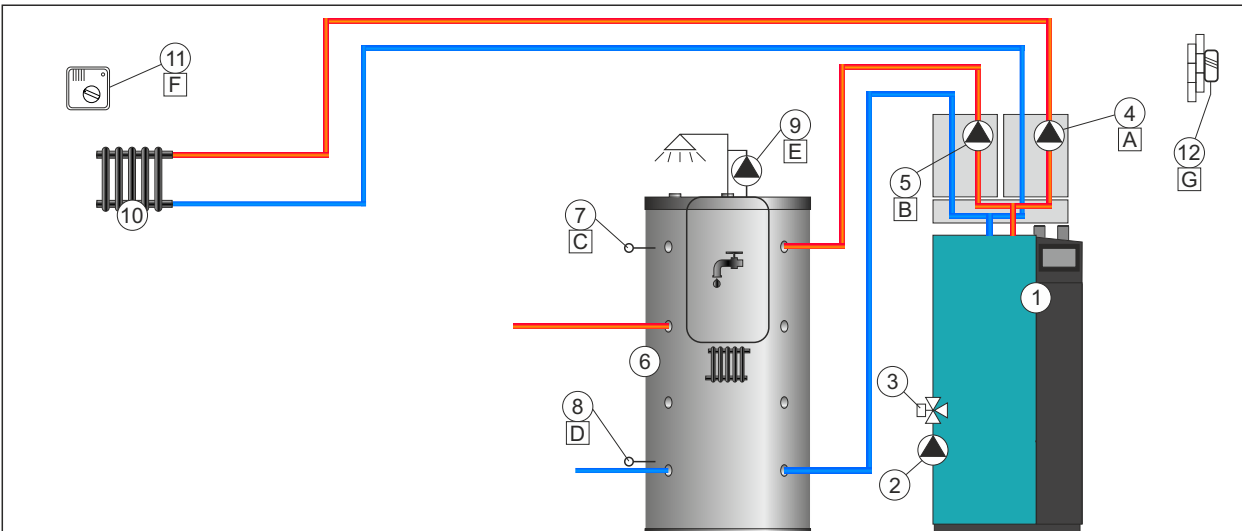

A	PUMPS
P1	
B	PUMPS
P2	
C	S5
	Buffer up
D	S3
	Buffer down
E	PUMPS
	P3
CSK	
CSK1	
F	1.P 2.G 3.T
CSK-Touch	
CSKT	
F	+ -
G	S8
	Outdoor

- 1 - Boiler PelTec-Compact
- 2 - P(PWM) - (Boiler circuit)
- 3 - MIXING VALVE (3-way mixing valve with actuator - boiler circuit)
- 4 - P1 - (Heating circuit 1 (K1))
- 5 - P2 - BUF (accumulation (buffer) tank)
- 6 - "CAS-B" accumulation (buffer) tank
- 7 - Temperature sensor (UP) - accumulation (buffer) tank
- 8 - Temperature sensor (DOWN) - accumulation (buffer) tank
- 9 - P3 - Recirculation DHW
- 10 - (K1) Heating circuit 1 - (direct circuit)
- 11 - Room corrector CSK 1 ((K1) heating circuit 1) / CSK-Touch / Room thermostat
- 12 - Outdoor temperature sensor

Notes:

- in this configuration is possible to connect to the accumulation (buffer) tank or to the hydraulic crossover of the boiler (CRO ON) up to 3 unit "CM2K module for regulation 2 heating circuits".
- the first CSK-Touch can be connected to the boiler wired or wirelessly, the second CSK-Touch can only be connected wirelessly.

CONFIGURATION 28

CRO ON

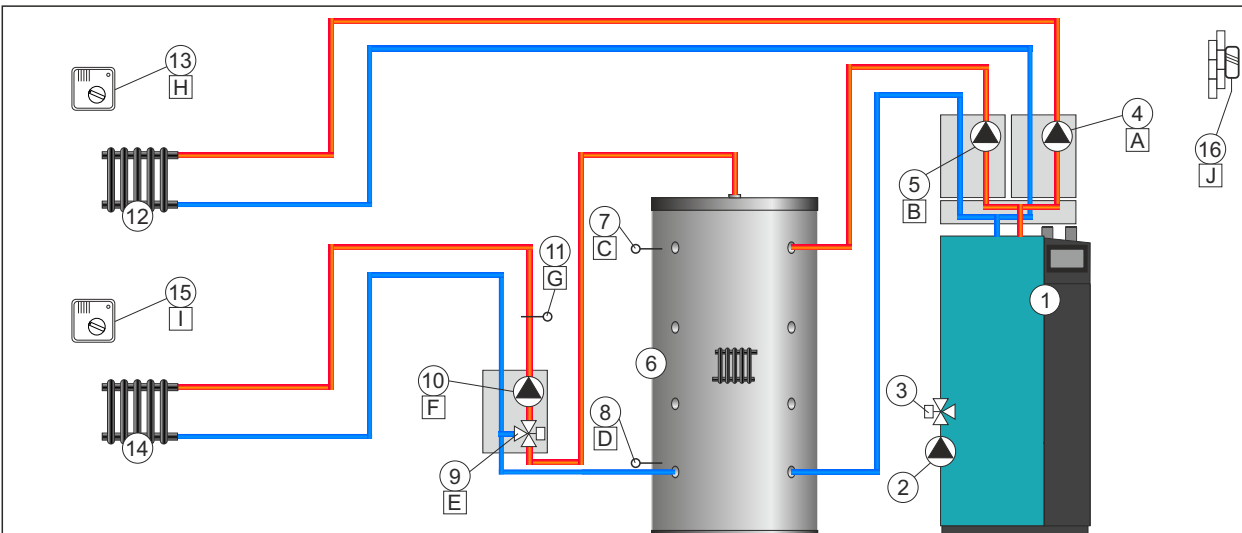

A	PUMPS
P1	
B	PUMPS
P2	
C	S5
	Buffer up
D	S3
	Buffer down
E	MIX VALVE
	CL1 OP1
F	PUMPS
	P3
G	S4
	Circuit 1
CSK 2	
CSK2	
H	1.P 2.G 3.T
CSK 1	
CSK1	
I	1.P 2.G 3.T
CSK-Touch 1	
CSKT	
I	+ -
J	S8
	Outdoor

- 1 - Boiler PelTec-Compact
- 2 - P(PWM) - (Boiler circuit)
- 3 - MIXING VALVE (3-way mixing valve with actuator - boiler circuit)
- 4 - P1 - (Heating circuit 2 (K2))
- 5 - P2 - BUF (accumulation (buffer) tank)
- 6 - "CAS" accumulation (buffer) tank
- 7 - Temperature sensor (UP) - accumulation (buffer) tank
- 8 - Temperature sensor (DOWN) - accumulation (buffer) tank
- 9 - MIXING VALVE 1 (3-way mixing valve with actuator - heating circuit 1 (K1))
- 10 - P3 - (Heating circuit 1 (K1))
- 11 - Temperature sensor ((K1) Heating circuit 1 - main flow)
- 12 - (K2) Heating circuit 2 - (direct circuit)
- 13 - Room corrector CSK 2 ((K2) heating circuit 2) / CSK-Touch / Room thermostat
- 14 - (K1) Heating circuit 1 (with mixing valve 1)
- 15 - Room corrector CSK 1 ((K1) heating circuit 1) / CSK-Touch / Room thermostat
- 16 - Outdoor temperature sensor

Notes:

- in this configuration is possible to connect to the accumulation (buffer) tank or to the hydraulic crossover of the boiler (CRO ON) up to 3 unit "CM2K module for regulation 2 heating circuits".
- the first CSK-Touch can be connected to the boiler wired or wirelessly, the second CSK-Touch can only be connected wirelessly.

CONFIGURATION 29

CRO ON

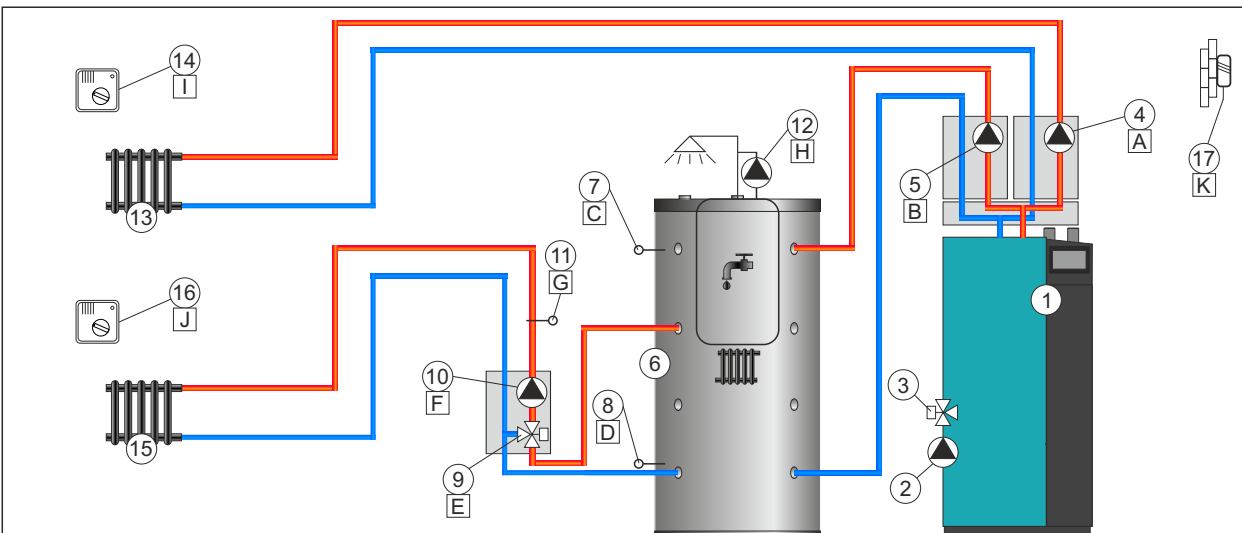

- 1 - Boiler PelTec-Compact
- 2 - P(PWM) - (Boiler circuit)
- 3 - MIXING VALVE (3-way mixing valve with actuator - boiler circuit)
- 4 - P1 - (Heating circuit 2 (K2))
- 5 - P2 - BUF (accumulation (buffer) tank)
- 6 - "CAS-B" accumulation (buffer) tank
- 7 - Temperature sensor (UP) - accumulation (buffer) tank
- 8 - Temperature sensor (DOWN) - accumulation (buffer) tank
- 9 - MIXING VALVE 1 (3-way mixing valve with actuator - heating circuit 1 (K1))
- 10 - P3 - (Heating circuit 1 (K1))
- 11 - Temperature sensor ((K1) Heating circuit 1 - main flow)
- 12 - P4 - Recirculation DHW
- 13 - (K2) Heating circuit 2 - (direct circuit)
- 14 - Room corrector CSK 2 ((K2) heating circuit 2) / CSK-Touch / Room thermostat
- 15 - (K1) Heating circuit 1 (with mixing valve 1)
- 16 - Room corrector CSK 1 ((K1) heating circuit 1) / CSK-Touch / Room thermostat
- 17 - Outdoor temperature sensor

Notes:

- in this configuration is possible to connect to the accumulation (buffer) tank or to the hydraulic crossover of the boiler (CRO ON) up to 3 unit "CM2K module for regulation 2 heating circuits".
- the first CSK-Touch can be connected to the boiler wired or wirelessly, the second CSK-Touch can only be connected wirelessly.

A	PUMPS	P1		
B	PUMPS	P2		
C	S5	Buffer up		
D	S3	Buffer down		
E	MIX VALVE	CL1 OP1		
F	PUMPS		P3	
G	S4	Circuit 1		
H	PUMPS			P4
CSK 2				
I	CSK2	1.P	2.G	3.T
CSK 1				
J	CSK1	1.P	2.G	3.T
CSK-Touch 1				
J	CSKT	+	-	
CSK 2				
K	S8	Outdoor		

CONFIGURATION 30

CRO ON

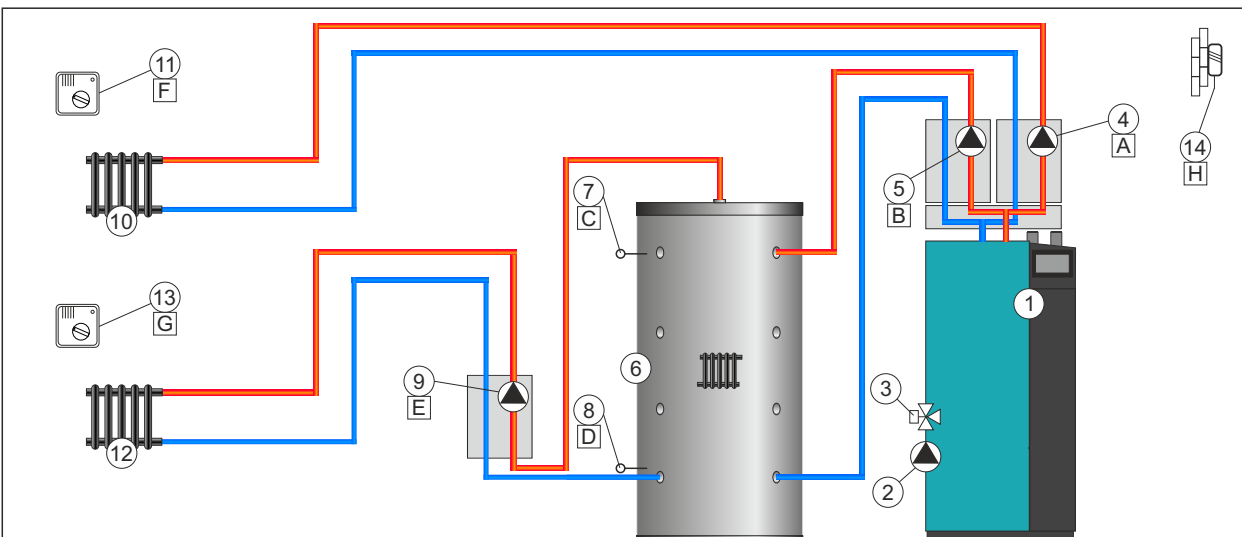

- 1 - Boiler PelTec-Compact
- 2 - P(PWM) - (Boiler circuit)
- 3 - MIXING VALVE (3-way mixing valve with actuator - boiler circuit)
- 4 - P1 - (Heating circuit 1 (K1))
- 5 - P2 - BUF (accumulation (buffer) tank)
- 6 - "CAS" accumulation (buffer) tank
- 7 - Temperature sensor (UP) - accumulation (buffer) tank
- 8 - Temperature sensor (DOWN) - accumulation (buffer) tank
- 9 - P3 - (Heating circuit 2 (K2))
- 10 - (K1) Heating circuit 1 - (direct circuit)
- 11 - Room corrector CSK 1 ((K1) heating circuit 1) / CSK-Touch / Room thermostat
- 12 - (K2) Heating circuit 2 - (direct circuit)
- 13 - Room corrector CSK 2 ((K2) heating circuit 2) / CSK-Touch / Room thermostat
- 14 - Outdoor temperature sensor

Notes:

- in this configuration is possible to connect to the accumulation (buffer) tank or to the hydraulic crossover of the boiler (CRO ON) up to 3 unit "CM2K module for regulation 2 heating circuits".
- the first CSK-Touch can be connected to the boiler wired or wirelessly, the second CSK-Touch can only be connected wirelessly.

A	PUMPS	P1		
B	PUMPS	P2		
C	S5	Buffer up		
D	S3	Buffer down		
E	PUMPS		P3	
CSK 1				
F	CSK1	1.P	2.G	3.T
CSK-Touch 1				
F	CSKT	+	-	
CSK 2				
G	CSK1	1.P	2.G	3.T
CSK 2				
H	S8	Outdoor		

CONFIGURATION 31

CRO ON

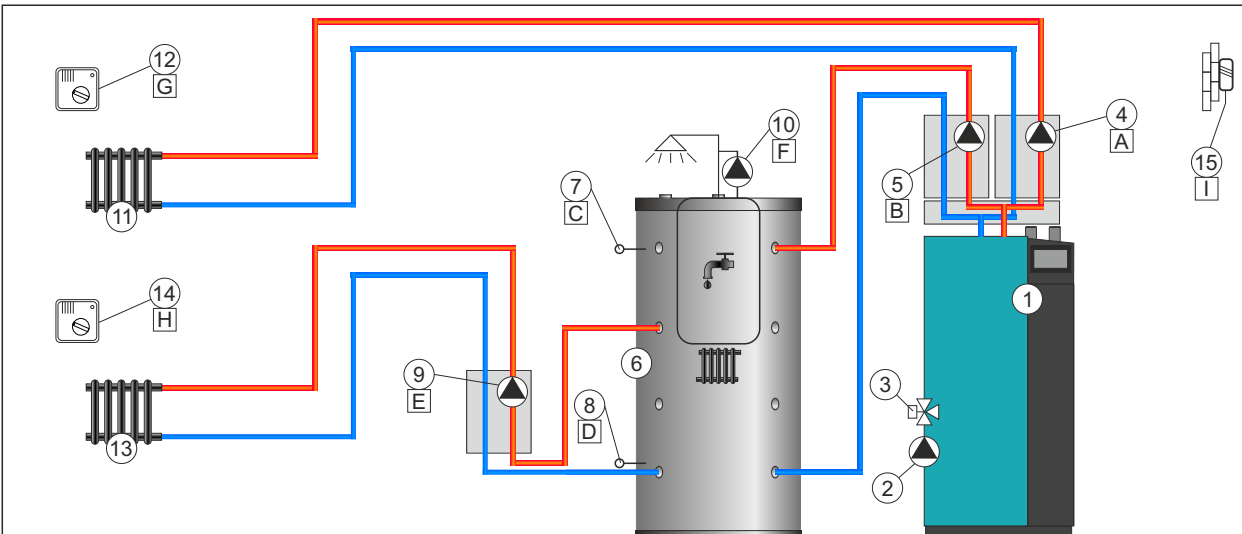

- 1 - Boiler PelTec-Compact
- 2 - P(PWM) - (Boiler circuit)
- 3 - MIXING VALVE (3-way mixing valve with actuator - boiler circuit)
- 4 - P1 - (Heating circuit 1 (K1))
- 5 - P2 - BUF (accumulation (buffer) tank)
- 6 - "CAS-B" accumulation (buffer) tank
- 7 - Temperature sensor (UP) - accumulation (buffer) tank
- 8 - Temperature sensor (DOWN) - accumulation (buffer) tank

- 9 - P3 - (Heating circuit 2 (K2))
- 10 - P4 - Recirculation DHW
- 11 - (K1) Heating circuit 1 - (direct circuit)
- 12 - Room corrector CSK 1 ((K1) heating circuit 1) / CSK-Touch / Room thermostat
- 13 - (K2) Heating circuit 2 - (direct circuit)
- 14 - Room corrector CSK 2 ((K2) heating circuit 2) / CSK-Touch / Room thermostat
- 15 - Outdoor temperature sensor

Notes:

- in this configuration is possible to connect to the accumulation (buffer) tank or to the hydraulic crossover of the boiler (CRO ON) up to 3 unit "CM2K module for regulation 2 heating circuits".
- the first CSK-Touch can be connected to the boiler wired or wirelessly, the second CSK-Touch can only be connected wirelessly.

A	PUMPS
P1	
B	PUMPS
P2	
C	S5
	Buffer up
D	S3
	Buffer down
E	PUMPS
	P3
F	PUMPS
	P4
CSK 1	
G	CSK1
	1.P 2.G 3.T
CSK-Touch 1	
G	CSKT
	+ -
CSK 2	
H	CSK1
	1.P 2.G 3.T
CSK-Touch 2	
H	CSKT
	+ -
I	S8
	Outdoor

CONFIGURATION 32

CRO ON

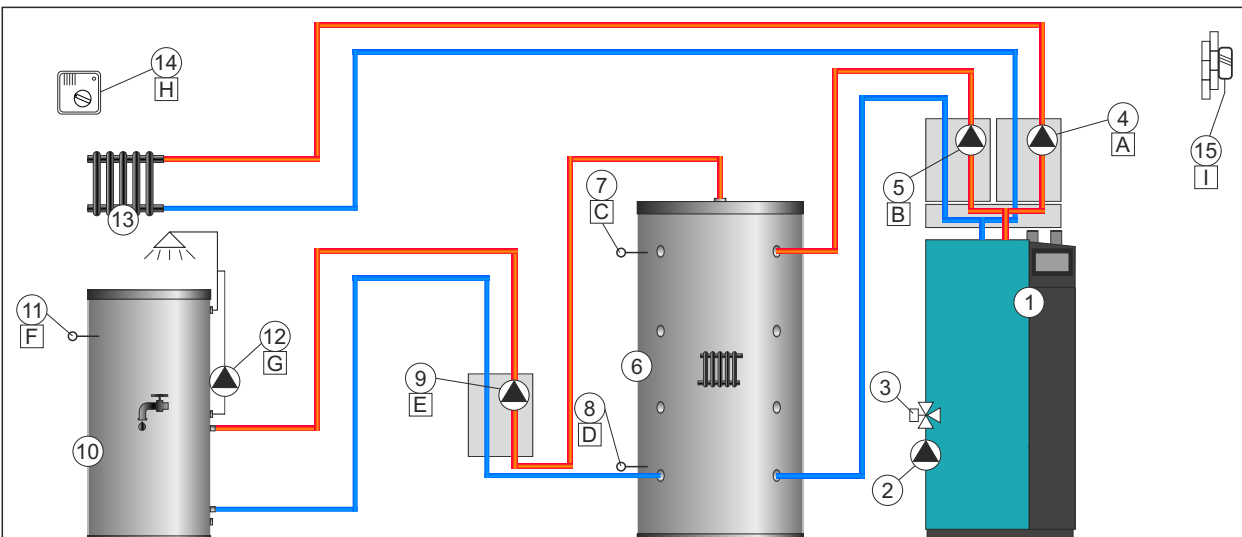

- 1 - Boiler PelTec-Compact
- 2 - P(PWM) - (Boiler circuit)
- 3 - MIXING VALVE (3-way mixing valve with actuator - boiler circuit)
- 4 - P1 - (Heating circuit 1 (K1))
- 5 - P2 - BUF (accumulation (buffer) tank)
- 6 - "CAS" accumulation (buffer) tank
- 7 - Temperature sensor (UP) - accumulation (buffer) tank
- 8 - Temperature sensor (DOWN) - accumulation (buffer) tank

- 9 - P3 - DHW (Heating circuit 2 (K2))
- 10 - (K2) Heating circuit 2 (DHW)
- 11 - Temperature sensor DHW ((K2) Heating circuit 2)
- 12 - P4 - Recirculation DHW (Heating circuit 2 (K2))
- 13 - (K1) Heating circuit 1 - (direct circuit)
- 14 - Room corrector CSK 1 ((K1) heating circuit 1) / CSK-Touch / Room thermostat
- 15 - Outdoor temperature sensor

Notes:

- in this configuration is possible to connect to the accumulation (buffer) tank or to the hydraulic crossover of the boiler (CRO ON) up to 3 unit "CM2K module for regulation 2 heating circuits".
- the first CSK-Touch can be connected to the boiler wired or wirelessly, the second CSK-Touch can only be connected wirelessly.

A	PUMPS
P1	
B	PUMPS
P2	
C	S5
	Buffer up
D	S3
	Buffer down
E	PUMPS
	P3
F	S6
	Circuit 2
G	PUMPS
	P4
CSK	
H	CSK1
	1.P 2.G 3.T
CSK-Touch	
H	CSKT
	+ -
I	S8
	Outdoor

CONFIGURATION 33

CRO OFF

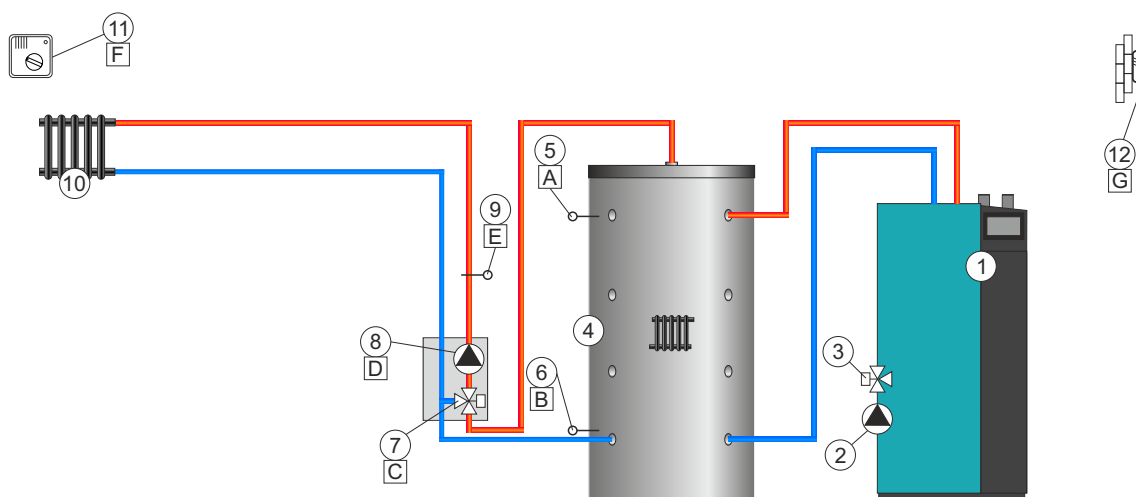

A	S5
	Buffer up
B	S3
	Buffer down
C	MIX VALVE
	CL1 OP1
D	PUMPS
	P1
E	S4
	Circuit 1
CSK	
F	CSK1
	1.P 2.G 3.T
CSK-Touch	
F	CSKT
	+ -
G	S8
	Outdoor

- 1 - Boiler PelTec-Compact
- 2 - P(PWM) - (Boiler circuit)
- 3 - MIXING VALVE (3-way mixing valve with actuator - boiler circuit)
- 4 - "CAS" accumulation (buffer) tank
- 5 - Temperature sensor (UP) - accumulation (buffer) tank
- 6 - Temperature sensor (DOWN) - accumulation (buffer) tank
- 7 - MIXING VALVE 1 (3-way mixing valve with actuator - heating circuit 1 (K1))
- 8 - P1 - (Heating circuit 1 (K1))
- 9 - Temperature sensor ((K1) Heating circuit 1 - main flow)
- 10 - (K1) Heating circuit 1 (with mixing valve 1)
- 11 - Room corrector CSK 1 ((K1) heating circuit 1) / CSK-Touch / Room thermostat
- 12 - Outdoor temperature sensor

Notes:

- in this configuration is possible to connect to the accumulation (buffer) tank up to 3 unit "CM2K module for regulation 2 heating circuits".
- the first CSK-Touch can be connected to the boiler wired or wirelessly, the second CSK-Touch can only be connected wirelessly.

CONFIGURATION 34

CRO OFF

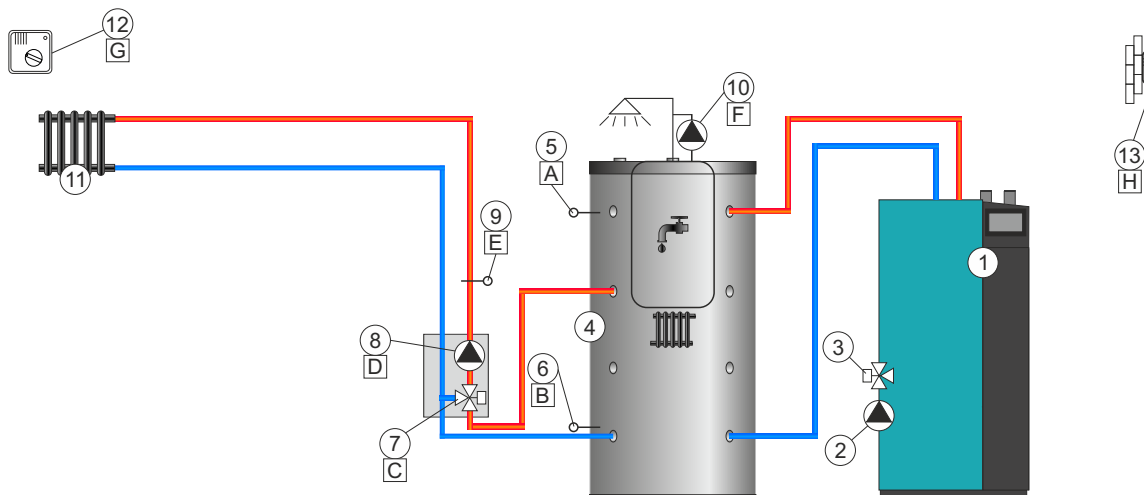

A	S5
	Buffer up
B	S3
	Buffer down
C	MIX VALVE
	CL1 OP1
D	PUMPS
	P1
E	S4
	Circuit 1
CSK	
F	PUMPS
	P2
CSK	
G	CSK1
	1.P 2.G 3.T
CSK-Touch	
G	CSKT
	+ -
H	S8
	Outdoor

- 1 - Boiler PelTec-Compact
- 2 - P(PWM) - (Boiler circuit)
- 3 - MIXING VALVE (3-way mixing valve with actuator - boiler circuit)
- 4 - "CAS-B" accumulation (buffer) tank
- 5 - Temperature sensor (UP) - accumulation (buffer) tank
- 6 - Temperature sensor (DOWN) - accumulation (buffer) tank
- 7 - MIXING VALVE 1 (3-way mixing valve with actuator - heating circuit 1 (K1))
- 8 - P1 - (Heating circuit 1 (K1))
- 9 - Temperature sensor ((K1) Heating circuit 1 - main flow)
- 10 - P2 - Recirculation DHW
- 11 - (K1) Heating circuit 1 (with mixing valve 1)
- 12 - Room corrector CSK 1 ((K1) heating circuit 1) / CSK-Touch / Room thermostat
- 13 - Outdoor temperature sensor

Notes:

- in this configuration is possible to connect to the accumulation (buffer) tank up to 3 unit "CM2K module for regulation 2 heating circuits".
- the first CSK-Touch can be connected to the boiler wired or wirelessly, the second CSK-Touch can only be connected wirelessly.

CONFIGURATION 35

CRO OFF

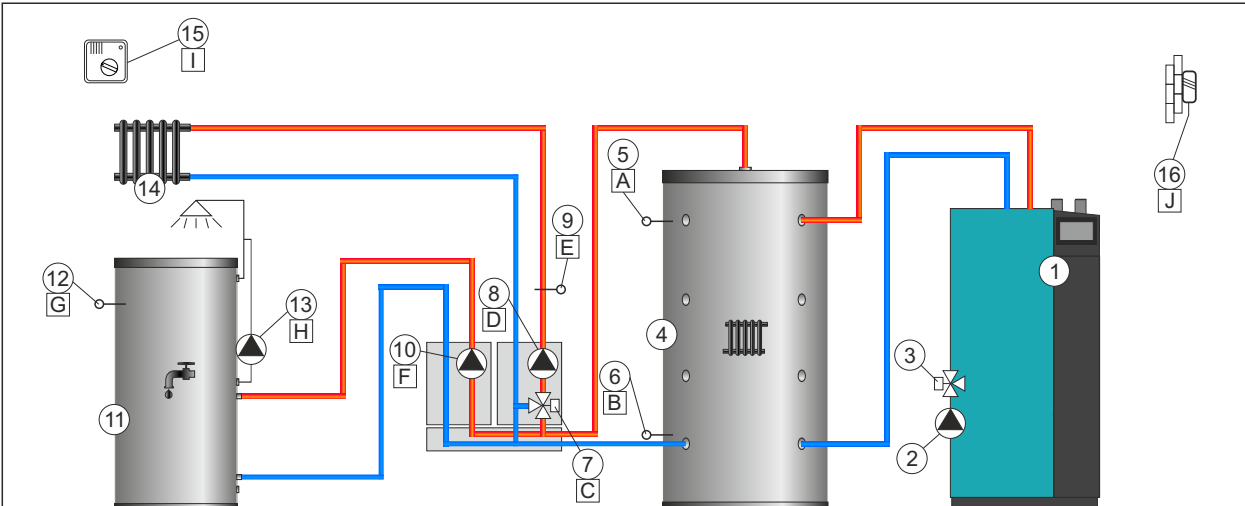

- 1 - Boiler PelTec-Compact
- 2 - **P(PWM)** - (Boiler circuit)
- 3 - MIXING VALVE (3-way mixing valve with actuator - boiler circuit)
- 4 - "CAS" accumulation (buffer) tank
- 5 - Temperature sensor (UP) - accumulation (buffer) tank
- 6 - Temperature sensor (DOWN) - accumulation (buffer) tank
- 7 - MIXING VALVE 1 (3-way mixing valve with actuator - heating circuit 1 (K1))
- 8 - **P1** - (Heating circuit 1 (K1))
- 9 - Temperature sensor ((K1) Heating circuit 1 - main flow)
- 10 - **P2** - DHW (Heating circuit 2 (K2))
- 11 - **(K2)** Heating circuit 2 (DHW)
- 12 - Temperature sensor DHW ((K2) Heating circuit 2)
- 13 - **P3** - Recirculation DHW (Heating circuit 2 (K2))
- 14 - **(K1)** Heating circuit 1 (with mixing valve 1)
- 15 - Room corrector CSK 1 ((K1) heating circuit 1) / CSK-Touch / Room thermostat
- 16 - Outdoor temperature sensor

Notes:

- in this configuration is possible to connect to the accumulation (buffer) tank up to 3 unit "CM2K module for regulation 2 heating circuits".
- the first CSK-Touch can be connected to the boiler wired or wirelessly, the second CSK-Touch can only be connected wirelessly.

A	S5
	Buffer up
B	S3
	Buffer down
C	MIX VALVE
	CL1 OP1
D	PUMPS
	P1
E	S4
	Circuit 1
F	PUMPS
	P2
G	S6
	Circuit 2
H	PUMPS
	P3
CSK	
I	CSK1
	1.P 2.G 3.T
CSK-Touch	
	CSKT
I	+ -
J	S8
	Outdoor

CONFIGURATION 36

CRO OFF

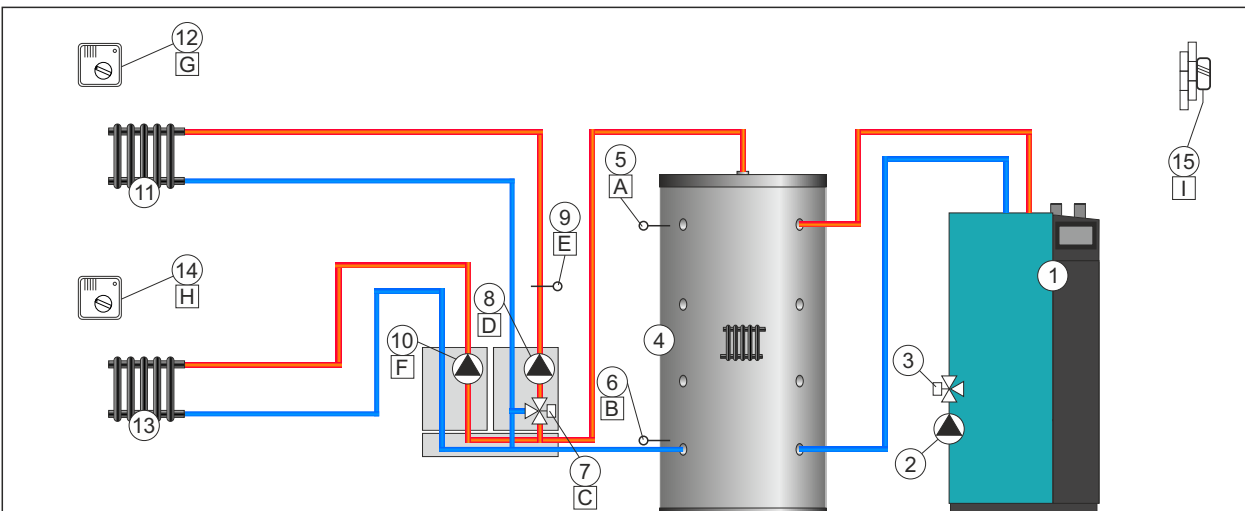

- 1 - Boiler PelTec-Compact
- 2 - **P(PWM)** - (Boiler circuit)
- 3 - MIXING VALVE (3-way mixing valve with actuator - boiler circuit)
- 4 - "CAS" accumulation (buffer) tank
- 5 - Temperature sensor (UP) - accumulation (buffer) tank
- 6 - Temperature sensor (DOWN) - accumulation (buffer) tank
- 7 - MIXING VALVE 1 (3-way mixing valve with actuator - heating circuit 1 (K1))
- 8 - **P1** - (Heating circuit 1 (K1))
- 9 - Temperature sensor ((K1) Heating circuit 1 - main flow)
- 10 - **P2** - (Heating circuit 2 (K2))
- 11 - **(K1)** Heating circuit 1 (with mixing valve 1) / CSK-Touch / Room thermostat
- 12 - Room corrector CSK 1 ((K1) heating circuit 1) / CSK-Touch / Room thermostat
- 13 - **(K2)** Heating circuit 2 - (direct circuit)
- 14 - Room corrector CSK 2 ((K2) heating circuit 2) / CSK-Touch / Room thermostat
- 15 - Outdoor temperature sensor

Notes:

- in this configuration is possible to connect to the accumulation (buffer) tank up to 3 unit "CM2K module for regulation 2 heating circuits".
- the first CSK-Touch can be connected to the boiler wired or wirelessly, the second CSK-Touch can only be connected wirelessly.

A	S5
	Buffer up
B	S3
	Buffer down
C	MIX VALVE
	CL1 OP1
D	PUMPS
	P1
E	S4
	Circuit 1
F	PUMPS
	P2
G	CSK 1
	CSK1
	1.P 2.G 3.T
CSK-Touch 1	
	CSKT
G	+ -
CSK 2	
H	CSK1
	1.P 2.G 3.T
I	S8
	Outdoor

CONFIGURATION 37

CRO OFF

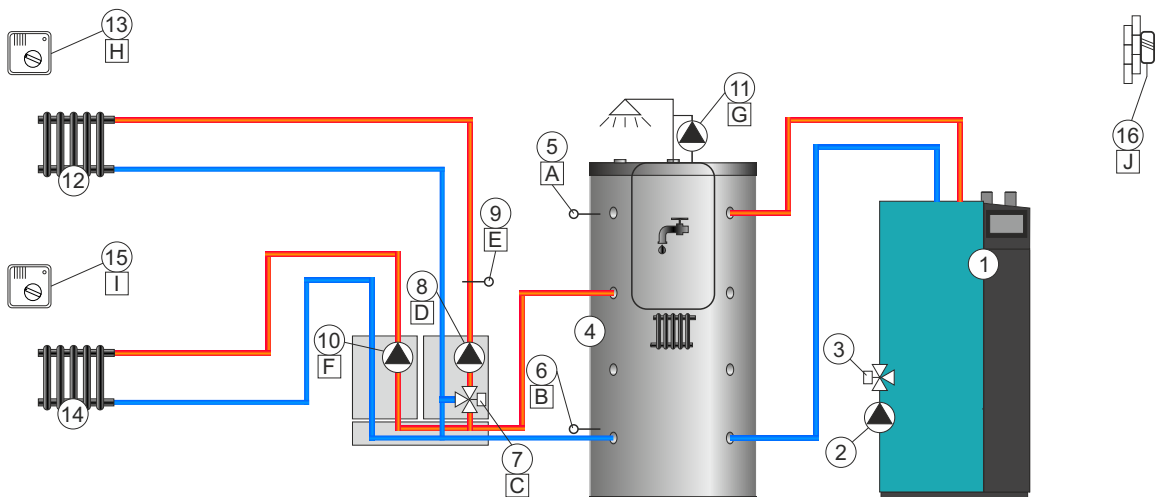

- 1 - Boiler PelTec-Compact
- 2 - **P(PWM)** - (Boiler circuit)
- 3 - MIXING VALVE (3-way mixing valve with actuator - boiler circuit)
- 4 - "CAS-B" accumulation (buffer) tank
- 5 - Temperature sensor (UP) - accumulation (buffer) tank
- 6 - Temperature sensor (DOWN) - accumulation (buffer) tank
- 7 - MIXING VALVE 1 (3-way mixing valve with actuator - heating circuit 1 (K1))
- 8 - **P1** - (Heating circuit 1 (K1))
- 9 - Temperature sensor ((K1) Heating circuit 1 - main flow)
- 10 - **P2** - (Heating circuit 2 (K2))
- 11 - **P3** - Recirculation DHW
- 12 - ((K1) Heating circuit 1 (with mixing valve 1))
- 13 - Room corrector CSK 1 ((K1) heating circuit 1) / CSK-Touch / Room thermostat
- 14 - ((K2) Heating circuit 2 - (direct circuit))
- 15 - Room corrector CSK 2 ((K2) heating circuit 2) / CSK-Touch / Room thermostat
- 16 - Outdoor temperature sensor

Notes:

- in this configuration is possible to connect to the accumulation (buffer) tank up to 3 unit "CM2K module for regulation 2 heating circuits".
- the first CSK-Touch can be connected to the boiler wired or wirelessly, the second CSK-Touch can only be connected wirelessly.

A	S5
	Buffer up
B	S3
	Buffer down
C	MIX VALVE
	CL1 OP1
D	PUMPS
	P1
E	S4
	Circuit 1
F	PUMPS
	P2
G	PUMPS
	P3
CSK 1	
H	CSK1
	1.P 2.G 3.T
CSK-Touch 1	
H	CSKT
	+ -
CSK 2	
I	CSK1
	1.P 2.G 3.T
J	S8
	Outdoor

CONFIGURATION 38

CRO OFF

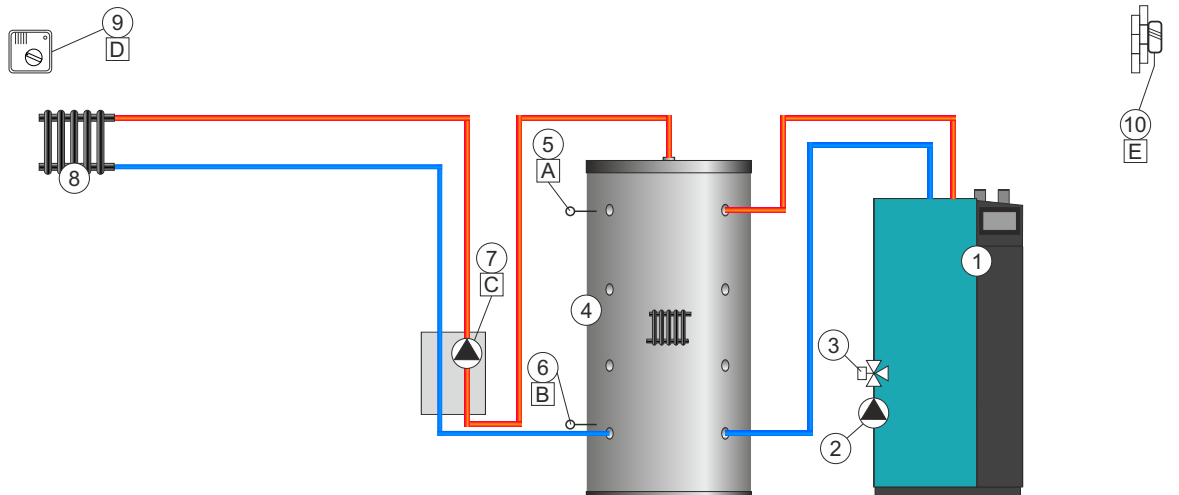

- 1 - Boiler PelTec-Compact
- 2 - **P(PWM)** - (Boiler circuit)
- 3 - MIXING VALVE (3-way mixing valve with actuator - boiler circuit)
- 4 - "CAS" accumulation (buffer) tank
- 5 - Temperature sensor (UP) - accumulation (buffer) tank
- 6 - Temperature sensor (DOWN) - accumulation (buffer) tank
- 7 - **P1** - (Heating circuit 1 (K1))
- 8 - ((K1) Heating circuit 1 - (direct circuit))
- 9 - Room corrector CSK 1 ((K1) heating circuit 1) / CSK-Touch / Room thermostat
- 10 - Outdoor temperature sensor

Notes:

- in this configuration is possible to connect to the accumulation (buffer) tank up to 3 unit "CM2K module for regulation 2 heating circuits".
- the first CSK-Touch can be connected to the boiler wired or wirelessly, the second CSK-Touch can only be connected wirelessly.

A	S5
	Buffer up
B	S3
	Buffer down
C	PUMPS
	P1
CSK	
D	CSK1
	1.P 2.G 3.T
CSK-Touch	
D	CSKT
	+ -
E	S8
	Outdoor

CONFIGURATION 39

CRO OFF

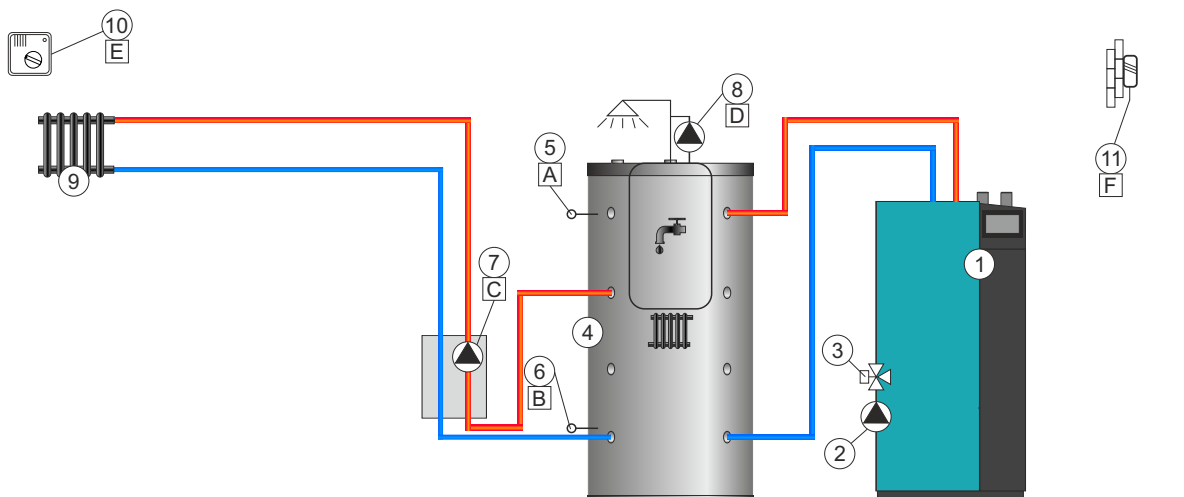

A	S5 Buffer up
B	S3 Buffer down
C	PUMPS P1
D	PUMPS P2
CSK	
E	CSK1 1.P 2.G 3.T
CSK-Touch	
E	CSKT + -
F	S8 Outdoor

- 1 - Boiler PelTec-Compact
- 2 - P(PWM) - (Boiler circuit)
- 3 - MIXING VALVE (3-way mixing valve with actuator - boiler circuit)
- 4 - "CAS-B" accumulation (buffer) tank
- 5 - Temperature sensor (UP) - accumulation (buffer) tank
- 6 - Temperature sensor (DOWN) - accumulation (buffer) tank
- 7 - P1 - (Heating circuit 1 (K1))
- 8 - P2 - Recirculation DHW
- 9 - (K1) Heating circuit 1 - (direct circuit)
- 10 - Room corrector CSK 1 ((K1) heating circuit 1) / CSK-Touch / Room thermostat
- 11 - Outdoor temperature sensor

Notes:
 - in this configuration is possible to connect to the accumulation (buffer) tank up to 3 unit "CM2K module for regulation 2 heating circuits".
 - the first CSK-Touch can be connected to the boiler wired or wirelessly, the second CSK-Touch can only be connected wirelessly.

CONFIGURATION 40

CRO OFF

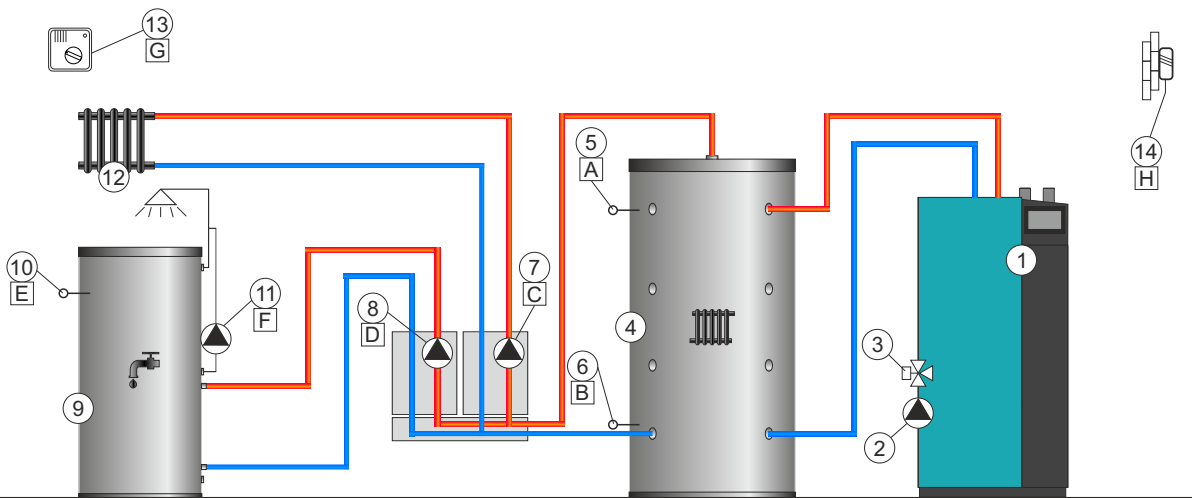

A	S5 Buffer up
B	S3 Buffer down
C	PUMPS P1
D	PUMPS P2
E	S6 Circuit 2
F	PUMPS P3
CSK	
G	CSK1 1.P 2.G 3.T
CSK-Touch	
G	CSKT + -
H	S8 Outdoor

- 1 - Boiler PelTec-Compact
- 2 - P(PWM) - (Boiler circuit)
- 3 - MIXING VALVE (3-way mixing valve with actuator - boiler circuit)
- 4 - "CAS" accumulation (buffer) tank
- 5 - Temperature sensor (UP) - accumulation (buffer) tank
- 6 - Temperature sensor (DOWN) - accumulation (buffer) tank
- 7 - P1 - (Heating circuit 1 (K1))
- 8 - P2 - DHW (Heating circuit 2 (K2))
- 9 - (K2) Heating circuit 2 (DHW)
- 10 - Temperature sensor DHW ((K2) Heating circuit 2)
- 11 - P3 - Recirculation DHW (Heating circuit 2 (K2))
- 12 - (K1) Heating circuit 1 - (direct circuit)
- 13 - Room corrector CSK 1 ((K1) heating circuit 1) / CSK-Touch / Room thermostat
- 14 - Outdoor temperature sensor

Notes:
 - in this configuration is possible to connect to the accumulation (buffer) tank up to 3 unit "CM2K module for regulation 2 heating circuits".
 - the first CSK-Touch can be connected to the boiler wired or wirelessly, the second CSK-Touch can only be connected wirelessly.

CONFIGURATION 41

CRO OFF

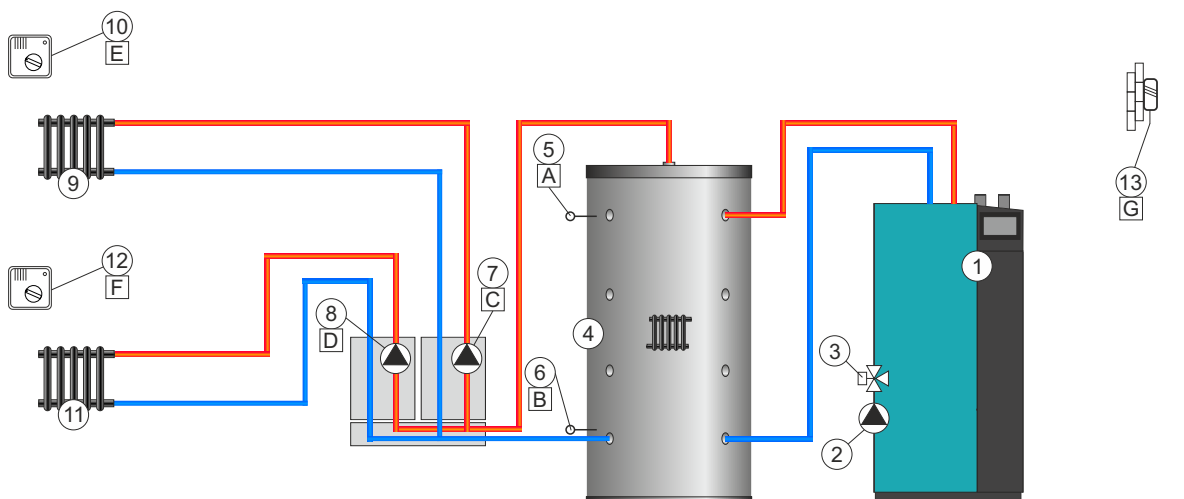

A	S5
	Buffer up
B	S3
	Buffer down
C	PUMPS
P1	
D	PUMPS
P2	
CSK 1	
E	CSK1
	1.P 2.G 3.T
CSK-Touch 1	
E	CSKT
	+ -
CSK 2	
F	CSK1
	1.P 2.G 3.T
G	S8
	Outdoor

- 1 - Boiler PelTec-Compact
- 2 - P(PWM) - (Boiler circuit)
- 3 - MIXING VALVE (3-way mixing valve with actuator - boiler circuit)
- 4 - "CAS" accumulation (buffer) tank
- 5 - Temperature sensor (UP) - accumulation (buffer) tank
- 6 - Temperature sensor (DOWN) - accumulation (buffer) tank
- 7 - P1 - (Heating circuit 1 (K1))
- 8 - P2 - (Heating circuit 2 (K2))
- 9 - (K1) Heating circuit 1 - (direct circuit)
- 10 - Room corrector CSK 1 ((K1) heating circuit 1) / CSK-Touch / Room thermostat
- 11 - (K2) Heating circuit 2 - (direct circuit)
- 12 - Room corrector CSK 2 ((K2) heating circuit 2) / CSK-Touch / Room thermostat
- 13 - Outdoor temperature sensor

Notes:
 - in this configuration is possible to connect to the accumulation (buffer) tank up to 3 unit "CM2K module for regulation 2 heating circuits".
 - the first CSK-Touch can be connected to the boiler wired or wirelessly, the second CSK-Touch can only be connected wirelessly.

CONFIGURATION 42

CRO OFF

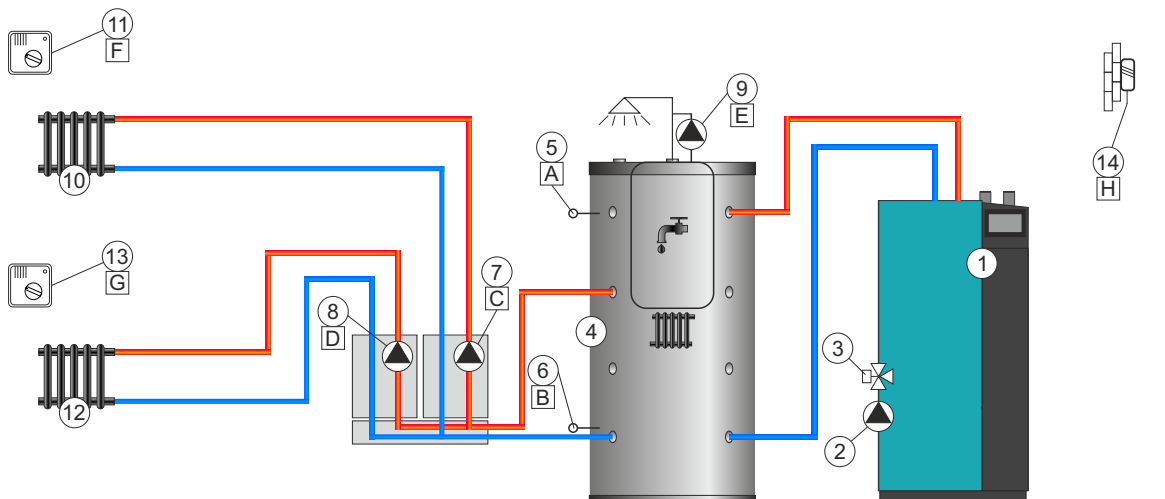

A	S5
	Buffer up
B	S3
	Buffer down
C	PUMPS
P1	
D	PUMPS
P2	
E	PUMPS
P3	
CSK 1	
F	CSK1
	1.P 2.G 3.T
CSK-Touch 1	
F	CSKT
	+ -
CSK 2	
G	CSK1
	1.P 2.G 3.T
H	S8
	Outdoor

- 1 - Boiler PelTec-Compact
- 2 - P(PWM) - (Boiler circuit)
- 3 - MIXING VALVE (3-way mixing valve with actuator - boiler circuit)
- 4 - "CAS-B" accumulation (buffer) tank
- 5 - Temperature sensor (UP) - accumulation (buffer) tank
- 6 - Temperature sensor (DOWN) - accumulation (buffer) tank
- 7 - P1 - (Heating circuit 1 (K1))
- 8 - P2 - (Heating circuit 2 (K2))
- 9 - P3 - Recirculation DHW
- 10 - (K1) Heating circuit 1 - (direct circuit)
- 11 - Room corrector CSK 1 ((K1) heating circuit 1) / CSK-Touch / Room thermostat
- 12 - (K2) Heating circuit 2 - (direct circuit)
- 13 - Room corrector CSK 2 ((K2) heating circuit 2) / CSK-Touch / Room thermostat
- 14 - Outdoor temperature sensor

Notes:
 - in this configuration is possible to connect to the accumulation (buffer) tank up to 3 unit "CM2K module for regulation 2 heating circuits".
 - the first CSK-Touch can be connected to the boiler wired or wirelessly, the second CSK-Touch can only be connected wirelessly.

CONFIGURATION 43

CRO OFF

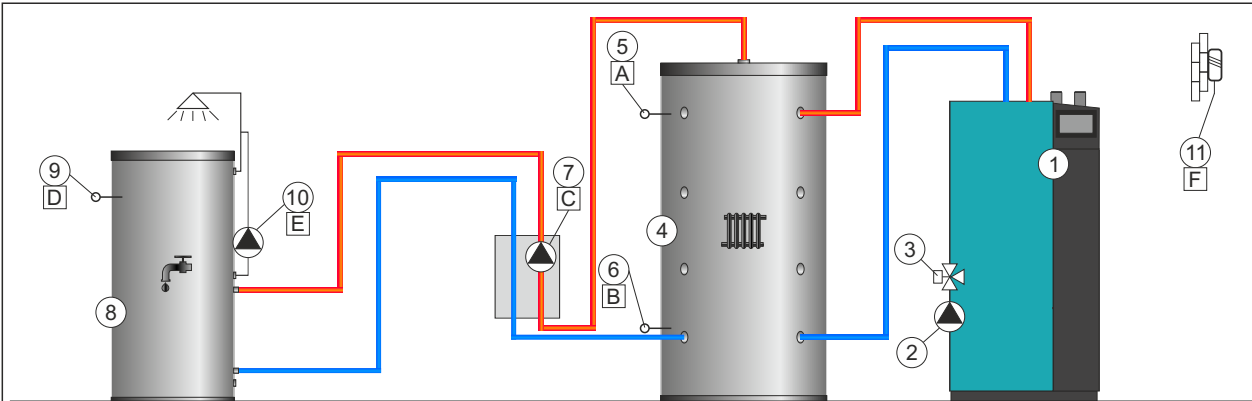

- | | |
|--|---|
| 1 - Boiler PelTec-Compact | 6 - Temperature sensor (DOWN) - accumulation (buffer) tank |
| 2 - P(PWM) - (Boiler circuit) | 7 - P1 - DHW (Heating circuit 1 (K1)) |
| 3 - MIXING VALVE (3-way mixing valve with actuator - boiler circuit) | 8 - (K1) Heating circuit 1 (DHW) |
| 4 - "CAS" accumulation (buffer) tank | 9 - Temperature sensor DHW ((K1) Heating circuit 1) |
| 5 - Temperature sensor (UP) - accumulation (buffer) tank | 10 - P2 - Recirculation DHW (Heating circuit 1 (K1)) |
| | 11 - Outdoor temperature sensor |

Notes:

- in this configuration is possible to connect to the accumulation (buffer) tank up to 3 unit "CM2K module for regulation 2 heating circuits".
- * in this configuration is possible to connect CSK-Touch (additional equipment) only if CM2K is installed.

A	S5	Buffer up
B	S3	Buffer down
C	PUMPS	
	P1	
D	S4	Circuit 1
E	PUMPS	
	P2	
F	S8	Outdoor
	CSK-Touch	
*	CSKT	
	+	-

CONFIGURATION 44

CRO OFF

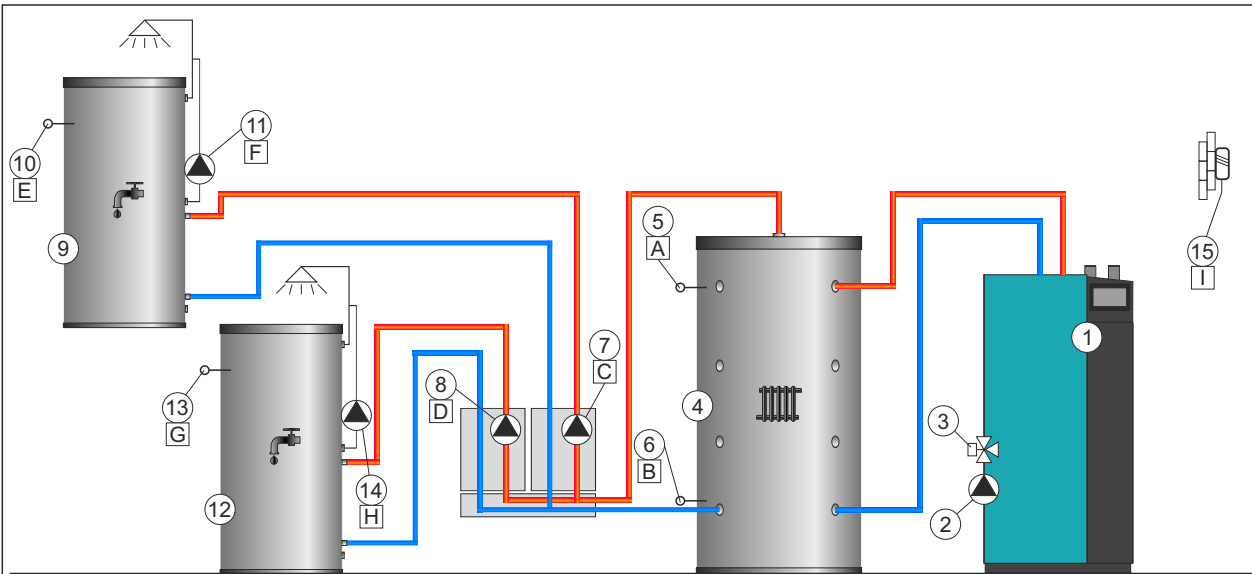

- | | |
|--|---|
| 1 - Boiler PelTec-Compact | 8 - P2 - DHW (Heating circuit 2 (K2)) |
| 2 - P(PWM) - (Boiler circuit) | 9 - (K1) Heating circuit 1 (DHW) |
| 3 - MIXING VALVE (3-way mixing valve with actuator - boiler circuit) | 10 - Temperature sensor DHW ((K1) Heating circuit 1) |
| 4 - "CAS" accumulation (buffer) tank | 11 - P3 - Recirculation DHW (Heating circuit 1 (K1)) |
| 5 - Temperature sensor (UP) - accumulation (buffer) tank | 12 - (K2) Heating circuit 2 (DHW) |
| 6 - Temperature sensor (DOWN) - accumulation (buffer) tank | 13 - Temperature sensor DHW ((K2) Heating circuit 2) |
| 7 - P1 - DHW (Heating circuit 1 (K1)) | 14 - P4 - Recirculation DHW (Heating circuit 2 (K2)) |
| | 15 - Outdoor temperature sensor |

Notes:

- in this configuration is possible to connect to the accumulation (buffer) tank up to 3 unit "CM2K module for regulation 2 heating circuits".
- * in this configuration is possible to connect CSK-Touch (additional equipment) only if CM2K is installed.

A	S5	Buffer up
B	S3	Buffer down
C	PUMPS	
	P1	
D	PUMPS	
	P2	
E	S4	Circuit 1
F	PUMPS	
	P3	
G	S6	Circuit 2
H	PUMPS	
	P4	
I	S8	Outdoor
	CSK-Touch	
*	CSKT	
	+	-

CONFIGURATION 45

CRO ON

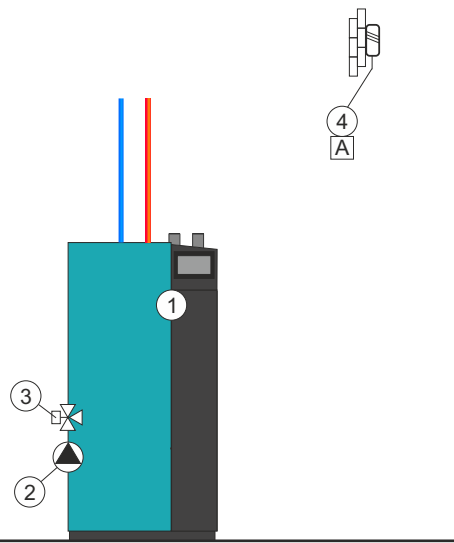

A	S8
	Outdoor
CSK-Touch	
*	CSKT
	+ -

1 - Boiler PelTec-Compact
 2 - P(PWM) - (Boiler circuit)

3 - MIXING VALVE (3-way mixing valve with actuator - boiler circuit)
 4 - Outdoor temperature sensor

Notes:
 - in this configuration is possible to connect to the hydraulic crossover of the boiler (CRO ON) up to 3 unit "CM2K module for regulation 2 heating circuits".
 * in this configuration is possible to connect CSK-Touch (additional equipment) only if CM2K is installed.

5.0. INSTALLATION OF PELLET SUPPLY

5.1. CONFIGURATION: Mole

The mole is an innovative technology for wood pellet feeding from a pellet tank towards an intermediate boiler pellet tank. Classical wood pellet feeding systems feed the pellet from the tank's bottom (the pellets move down) while the mole takes the pellets always from the upper tank part (the pellets do not move, the mole is moving). The classical pellet feeding systems must have slantwise sheets which take precious room for storing while the mole uses nearly the complete tank volume (the rest is max. 10 %). The mole is used for tanks with a ground plan until maximum 2,5 x 2,5 m, tank height from 1,8 to 2,5 m. In such dimensions the tank may be shaped circular or rectangular. When having bigger ground plan surfaces in the storage it is needed by help of sheets under an inclination of 45 degrees to adjust the surface in the room to the maximum allowed. The storage may be filled until maximum 30 cm below the ceiling. Recommendation is to use pellet trucks when filling the storage whereby the storage will be filled uniformly with the lowest dust percentage (it is need to install the set with tubes for the filling of pellets into the storage and the rubber protection curtain). The storage must be dry with a mounted checkup opening (minimum 80 x 80 cm) through which it is possible to put the mole into the storage filling position and to clean the storage from dust. The storage must be airtight due to the return of the dust from the vacuum suction system. If the storage is not airtight on the return tube it is needed to mount a dust bag. Maximum total (flow and return) pellet feeding tube length is 20 m + 5 m in the storage (distance from the storage to the boiler is about 10 m feeding tube length), maximum height difference (H) of the feeding tubes depends upon the total tube length (L) (flow and return): L = 15 m, H = 5 m or L = 20 m, H = 2,5 m. The height difference for the feeding system greater than 3 m must be interrupted with minimum 1 m horizontal positioned tubes. The tubes must be placed with maximum possible arcs. The tube bending radius must be minimum 30 cm. The maximum number of arches, with angle up to 90°, is 5. As an additional equipment it is possible to order a manual mole lifting system in the storage by help of sheaves. The system is tested to transport wood pellets with 6 mm diameter manufactured according to norm **DINplus** or **ENplusA1** with maximum dust content < 0,7 %.

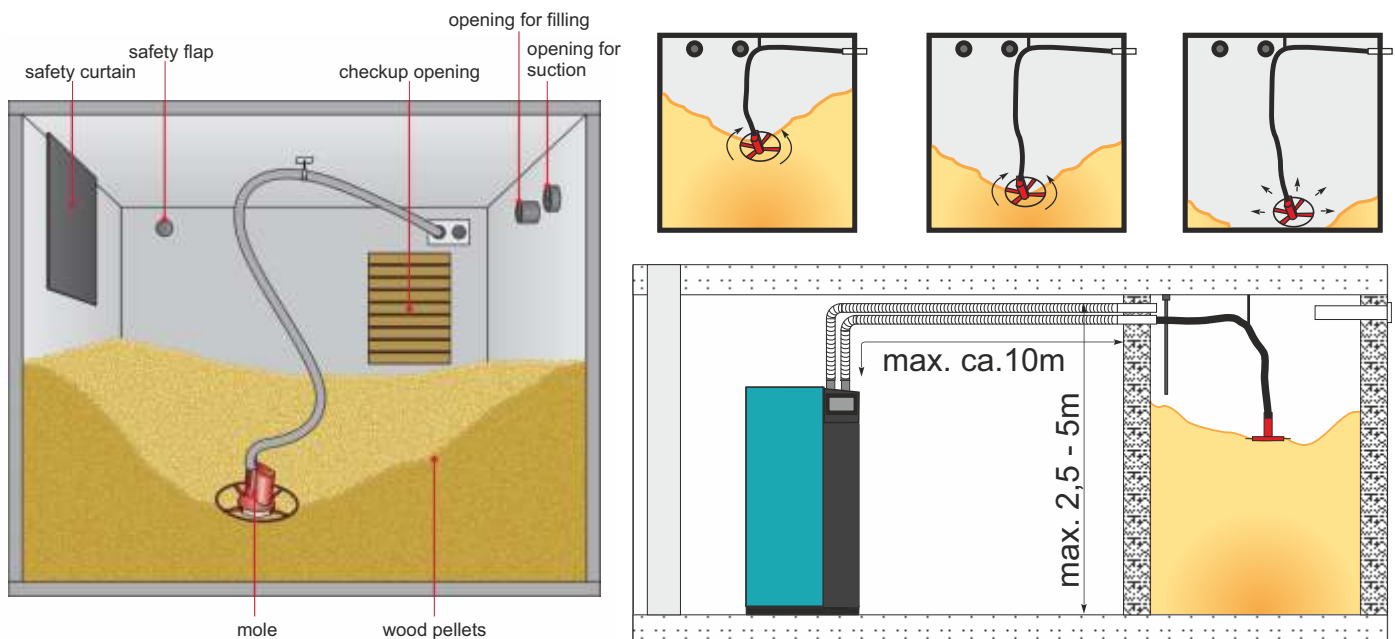

5.2. CONFIGURATION: Pellet tank

In wood pellet heating systems beside the boiler a pellet tank must be placed. Depending upon the boiler's power output and the wished operation autonomy, the pellet tank must sometimes have bigger dimensions which also requires bigger boiler rooms.

To solve the problem when having smaller boiler rooms which means a lack in pellet storing beside the boiler and in order to increase the comfort when heating with pellets by help of the suction system from the big pellet tank towards the tank beside the boiler it is possible to transport the pellets to a distance of 10 m flexible tube length. The tanks can have various volumes, CentroPelet Box 1,5 m³, 2,7 m³, 3,4 m³ and 4,0 m³ with the built in box for the pellet suction system. When having boiler cascades it is possible to connect 4 vacuum suction systems with one CentroPelet box which means that at the same time it is possible to feed 4 boilers with pellets. The distance between the CentroPelet box and the boiler may be maximum 10 m flexible pellet tube length. On the lower part of the CentroPelet box it is needed to mount the suction system box and to fasten on it the flow and return of the flexible tubes. The tanks can have following dimension: 1,5 m³, 2,7 m³, 3,4 m³ and 4 m³ in which one after the other 900 kg, 1700 kg, 2200 kg and 2600 kg of pellets can be placed. The tanks can be filled with 1000 kg pellet jumbo bags and 15 kg pellet bags. Maximum total suction system tube length (flow and return) is 20 m (distance from the tank to the boiler around 10 m), maximum height difference of the feeding tubes (H) depends upon the total tube length (L) (flow and return): L = 15 m, H = 5 m or L = 20 m, H = 2,5 m. The height difference for the feeding system greater than 3 m must be interrupted with minimum 1 m horizontal positioned tubes. The tubes must be placed with maximum possible arcs. The tube bending radius must be minimum 30 cm. The maximum number of arches, with angle up to 90°, is 5. Maximum vacuum suction system operation time during a day is 5 hours. The system is tested to transport wood pellets with 6 mm diameter manufactured according to norm **DINplus** or **ENplusA1** with maximum dust content < 0,7 %.

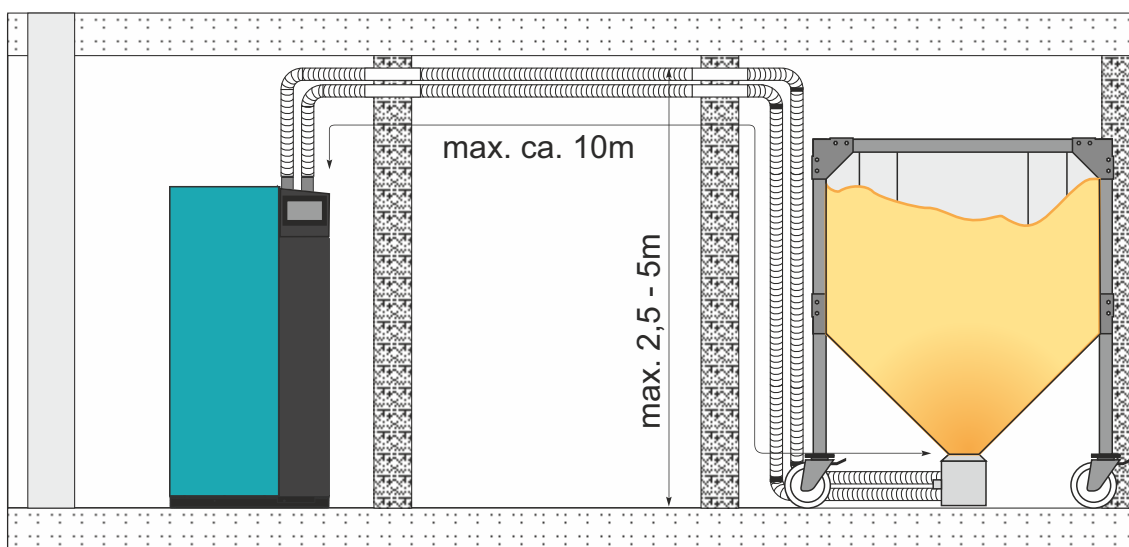

5.3. CONFIGURARION: Feeder screw

To solve the problem when having smaller boiler rooms which means a lack in pellet storing beside the boiler and in order to increase the comfort when heating with pellets by help of the suction system from the room towards the tank beside the boiler it is possible to transport the pellets to a distance of 20 m flexible tube length. The pellet feeder screw length can have 2 m, 3 m, 4 m and 5 m and according to this it is needed to adjust the slopes in the room with an inclination of 45 degrees. The distance between the room and the boiler may be maximum 10 m flexible pellet tube length. In the pellet rrom it is needed to mount the pellet feeder screw with the box and the motor gear and the slope sides (angle 45 degrees) towards the feeder screw. The room can be filled with pellet trucks (it is need to install the set with tubes for the filling of pellets into the storage and the rubber protection curtain), jumbo bags or smaller bags. The feeder screw box has to be connected with the suction system flexible tubes. Maximum total suction system tube length (flow and return) is 20 m (distance from the tank to the boiler around 10 m), maximum height difference of the feeding tubes (H) depends upon the total tube length (L) (flow and return): L = 15 m, H = 5 m or L = 20 m, H = 2,5 m. The height difference for the feeding system greater than 3 m must be interrupted with minimum 1 m horizontal positioned tubes. The tubes must be placed with maximum possible arcs. The tube bending radius must be minimum 30 cm. The maximum number of arches, with angle up to 90°, is 5. Maximum vacuum suction system operation time during a day is 5 hours. The system is tested to transport wood pellets with 6 mm diameter manufactured according to norm **DINplus** or **ENplusA1** with maximum dust content < 0,7 %.

Feeder screw	
length	motor with gearbox
2 m	0,18 kW
3 m	0,18 kW
4 m	0,18 kW
5 m	0,18 kW

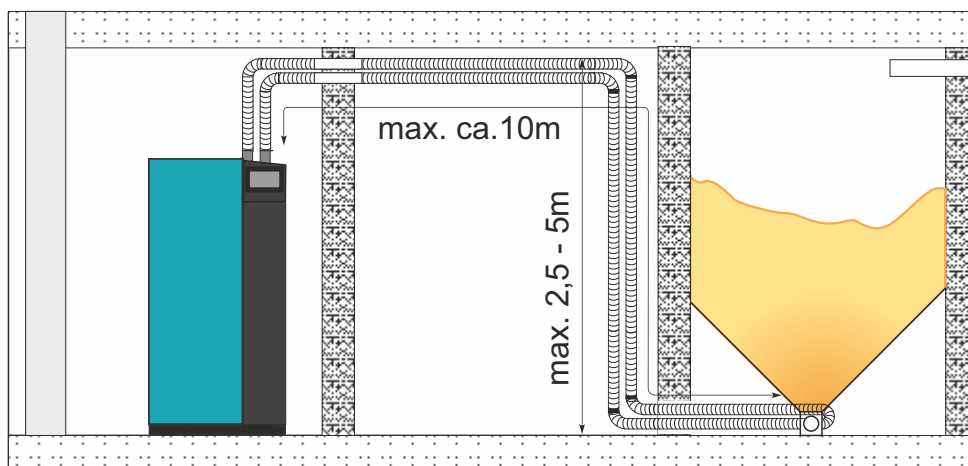
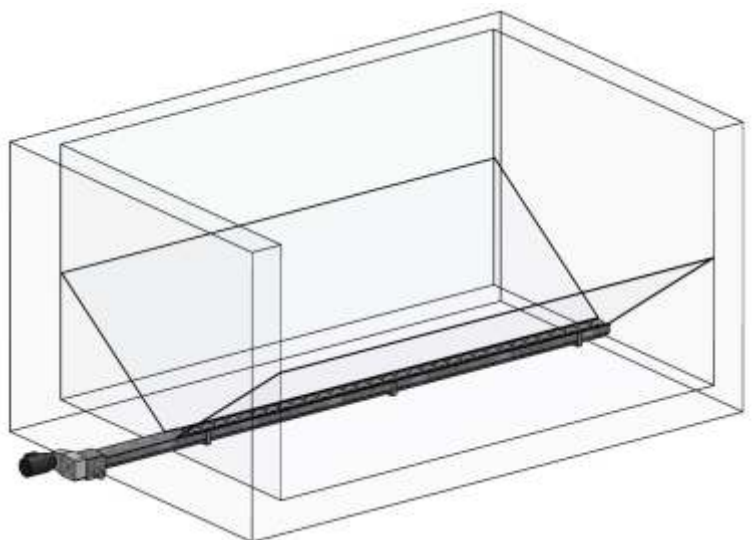

5.4. DELIVERY CONTENT (ADDITIONAL EQUIPMENT FOR CONFIGURATION: Mole)

Mole with electric drive, 5 m flexible antistatic tubes for pellet transportation, rubbed power cable Connector IP 67. Breakthrough (insertation) through the storage wall with 2 connections DN 50 for the suction and return tube - for storage walls thick up to 24 cm. Small material (screws, clamps, ...)



Picture: Mole content

5.5. DELIVERY CONTENT (ADDITIONAL EQUIPMENT FOR CONFIGURATION: Pellet tank)

Picture: CentroPelet Box - content.

Big pellet tank CentroPelet Box



Box for the pellet suction system
Small material (screws, ...)

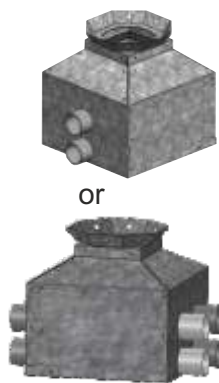

Box for the pellet suction system for up to 4 vacuum suction system

Mounting

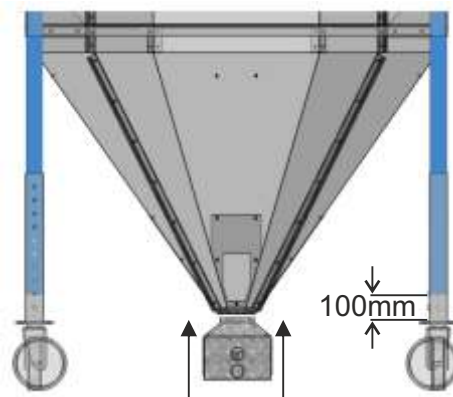

5.6. DELIVERY CONTENT (ADDITIONAL EQUIPMENT FOR CONFIGURATION: Feeder screw)

Picture: Screw feeder content

Screw feeder with gearbox and pellet supply box



If another screw feeder, not from the boiler manufacturer, is used in the "Feeder screw" configuration, it is necessary to check the operation and if the vacuum refill cannot work well (if it is being filled), it is necessary to adjust the *Time ON feeder screw* and *Time OFF feeder screw* times of the screw feeder under 'PIN' in the Installation menu. If the screw feeder does not have a 'End switch' to stop the screw feeder due to filling the screw feeder box, in the 'MODULE CVT' it is necessary to put a bridge (jumper) in place of the end switch (see the electrical scheme).

5.6.1. MOUNTING SCREW FEEDER IN THE PELLET STORAGE ROOM AND ELECTRICAL CONNECTION TO THE BOILER

Mounting screw feeder in the pellet storage room

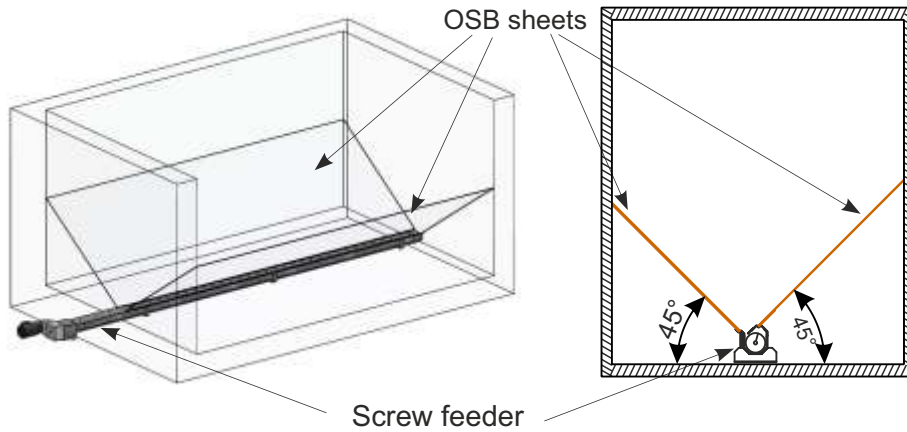

Electrical connection to the boiler

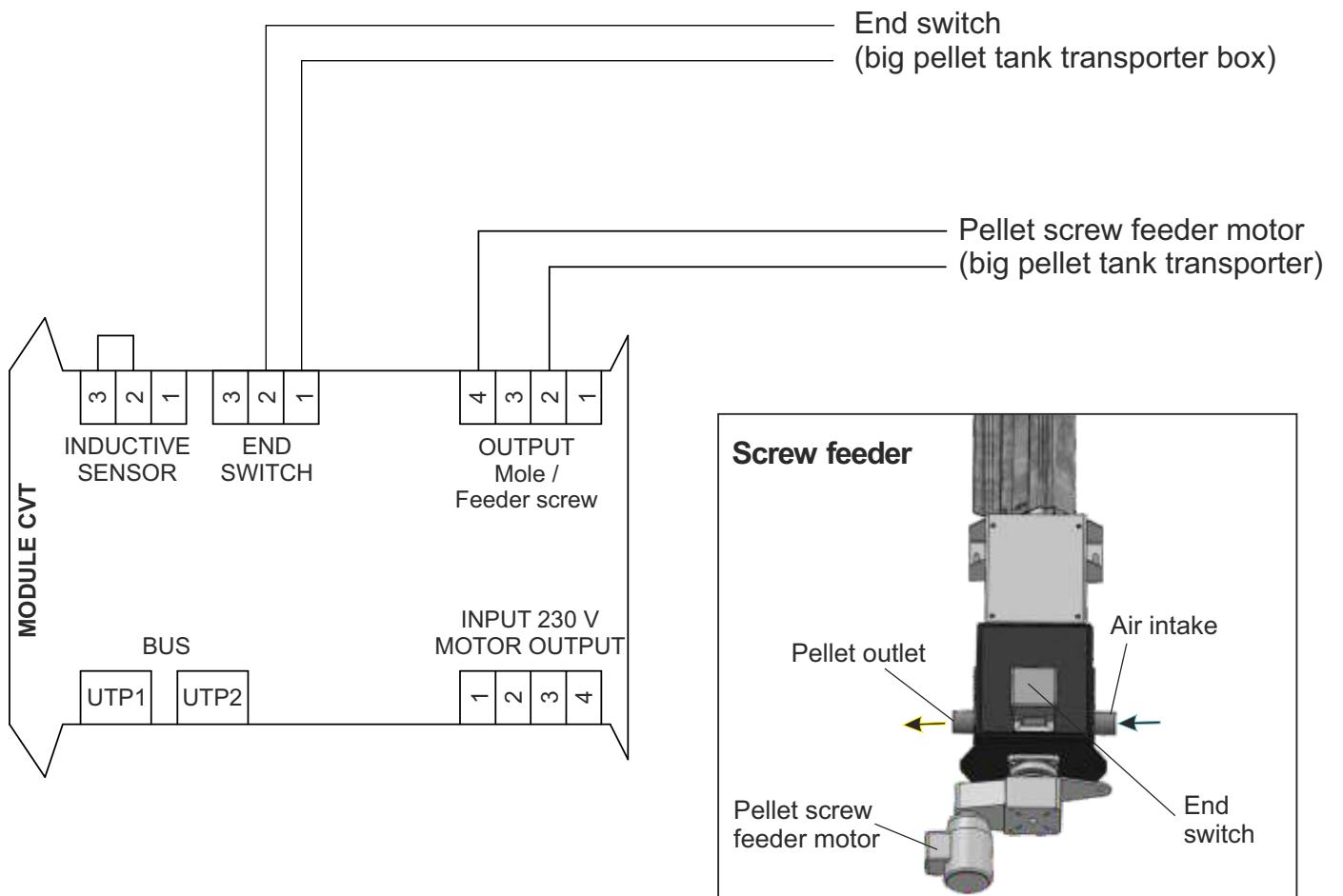

6.0. RECOMMENDED ADDITIONAL EQUIPMENT

Dust extraction cyclone (Type: CVDOP)

The cyclone is used for dust extraction from pellet suction feeding system in order to prevent dust accumulation in seasonal pellet storage through a longer usage period.

Configuration examples (with additional equipment)

1. Mole + CVDOP (Dust extraction cyclone)

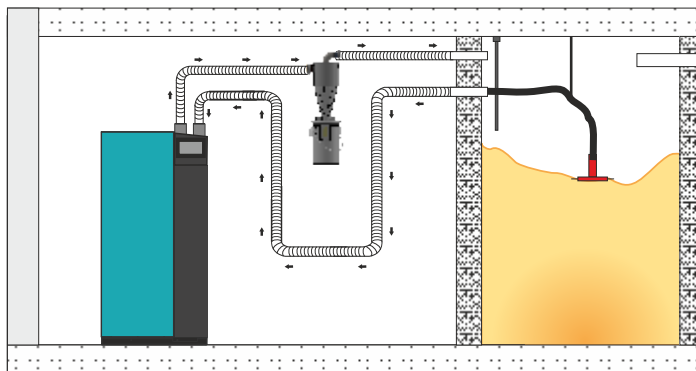

2. Pellet tank + CVDOP (Dust extraction cyclone)

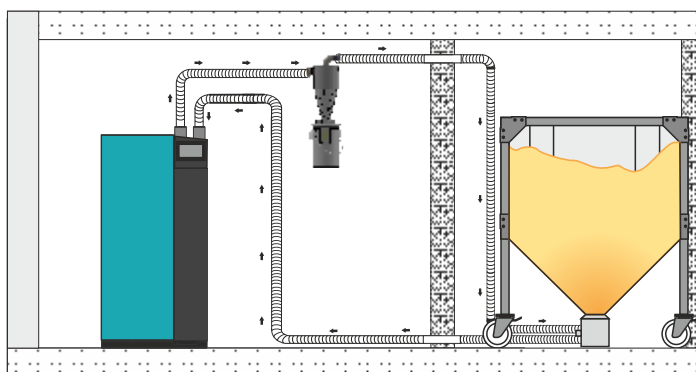

3. Feeder screw + CVDOP (Dust extraction cyclone)

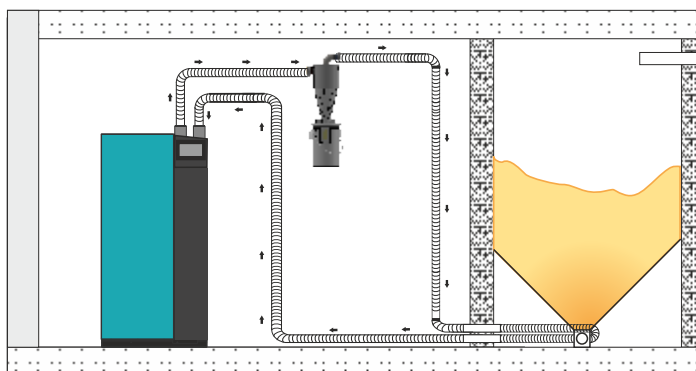

6.1. CONNECTION AND EARTHING OF THE TUBES ON THE VACUUM SUCTION SYSTEM



IMPORTANT!

Before turning on the boiler, it is necessary to earthing the PVC pipe for the pellet inlet and the PVC pipe for the air outlet.

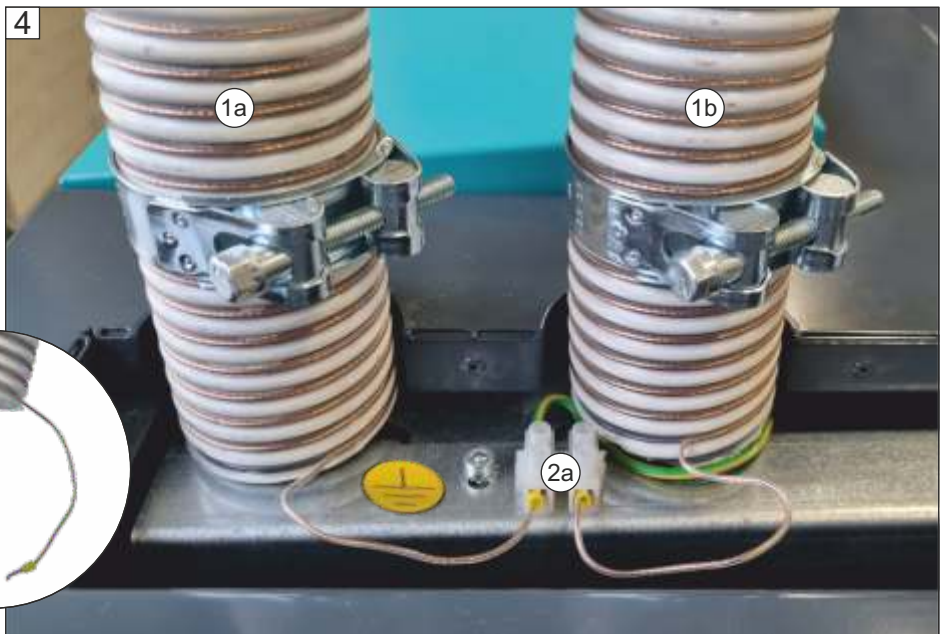
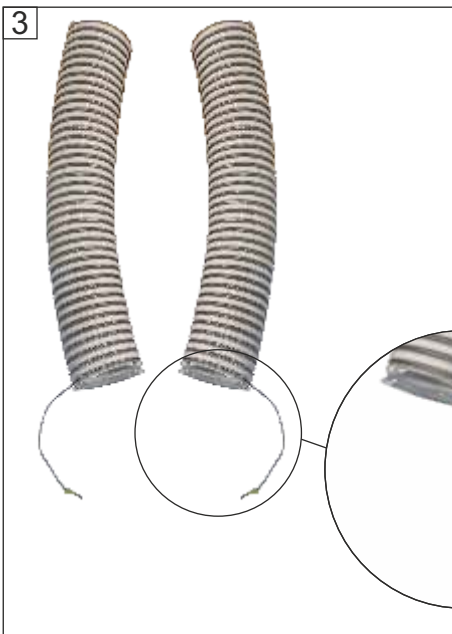
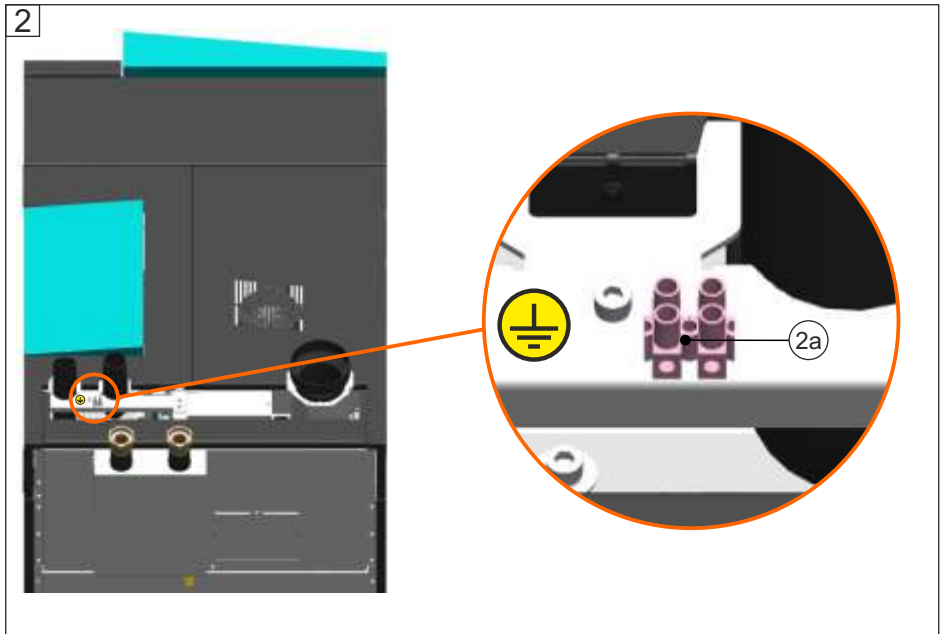

1. PVC pipe for pellet inlet (1a) and air outlet (1b) must be earthing. It is necessary to remove the top cover (1c) to access the earthing connector (2a).
2. The connector (2a) has two inlets, each for one pipe.
3. With the two PVC pipes, it is necessary to separate part of the wire.
4. Earthing the wires as shown in Figure 4.

The pipes on the vacuum suction system are fixed using the hose clamp.

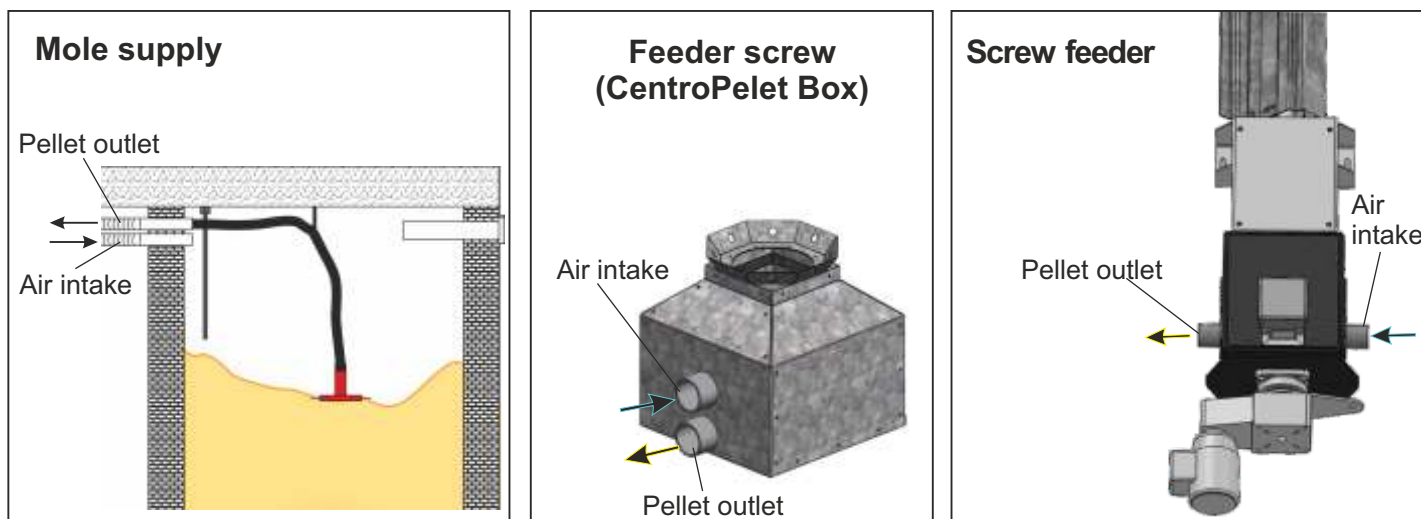

7.0. ELECTRICAL CONNECTIONS



IMPORTANT: Connect the electrical connection of the boiler permanently to the regular clamp of the boiler according to the attached scheme in these technical instructions, it is important to follow the markings of the conductors.

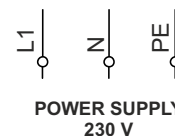

All electrical works must be performed by a certified professional in accordance with valid national and European standards. If the supply cord is damaged, it must be replaced by the manufacturer, its service agent or similarly qualified persons in order to avoid a hazard. A device for switching off all power supply poles must be installed in electrical installation in accordance with the national regulations on electrical installations.



CAUTION: When connecting any electrical part be sure to unplug the boiler at the main switch and disconnect the power supply.

7.1. MAIN FUSES / PCB (PRINTED CIRCUIT BOARD) POSITIONS / MODULE CVT

Main fuses / PCB (printed circuit board) positions:

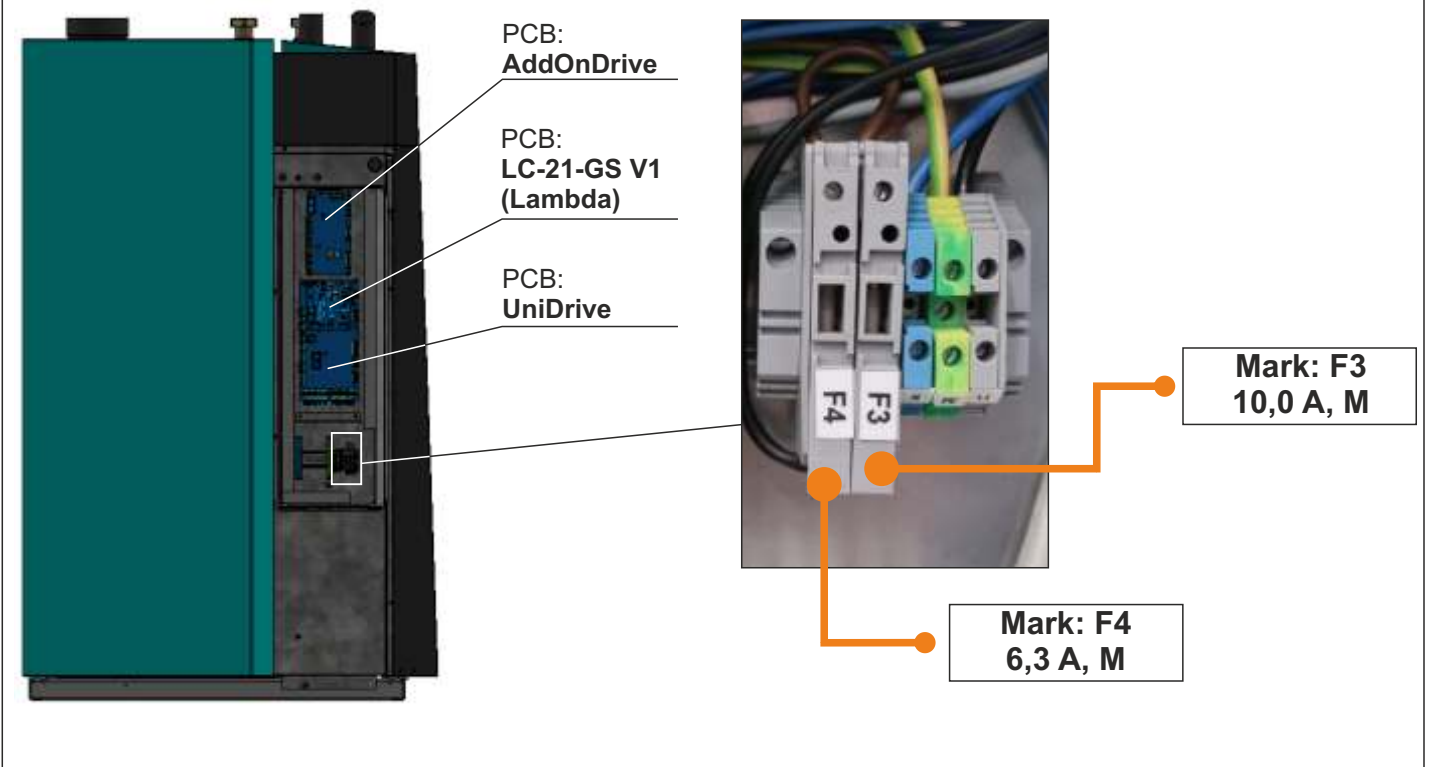

Main PCB: UniDrive

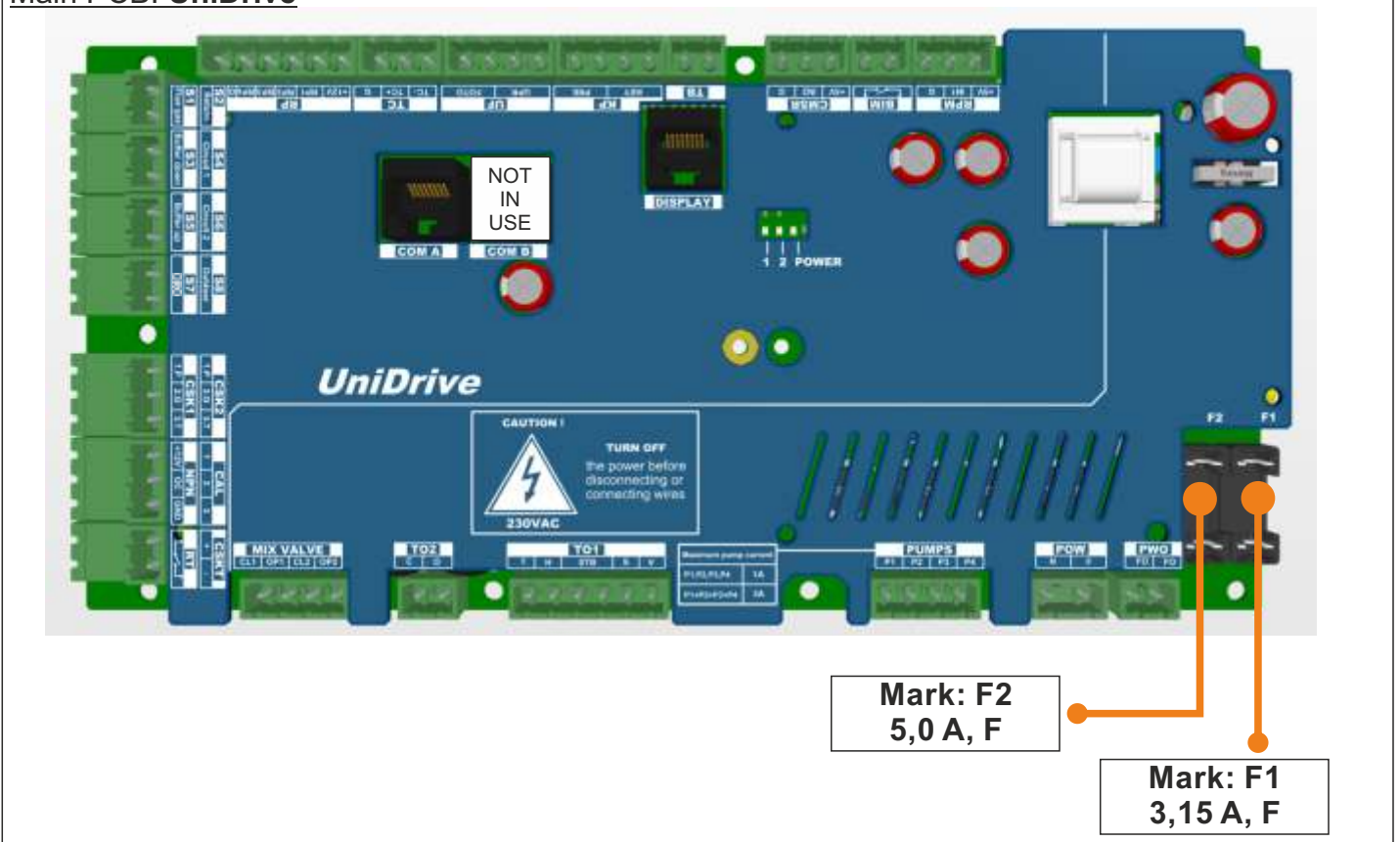

Additional PCB: AddOnDrive

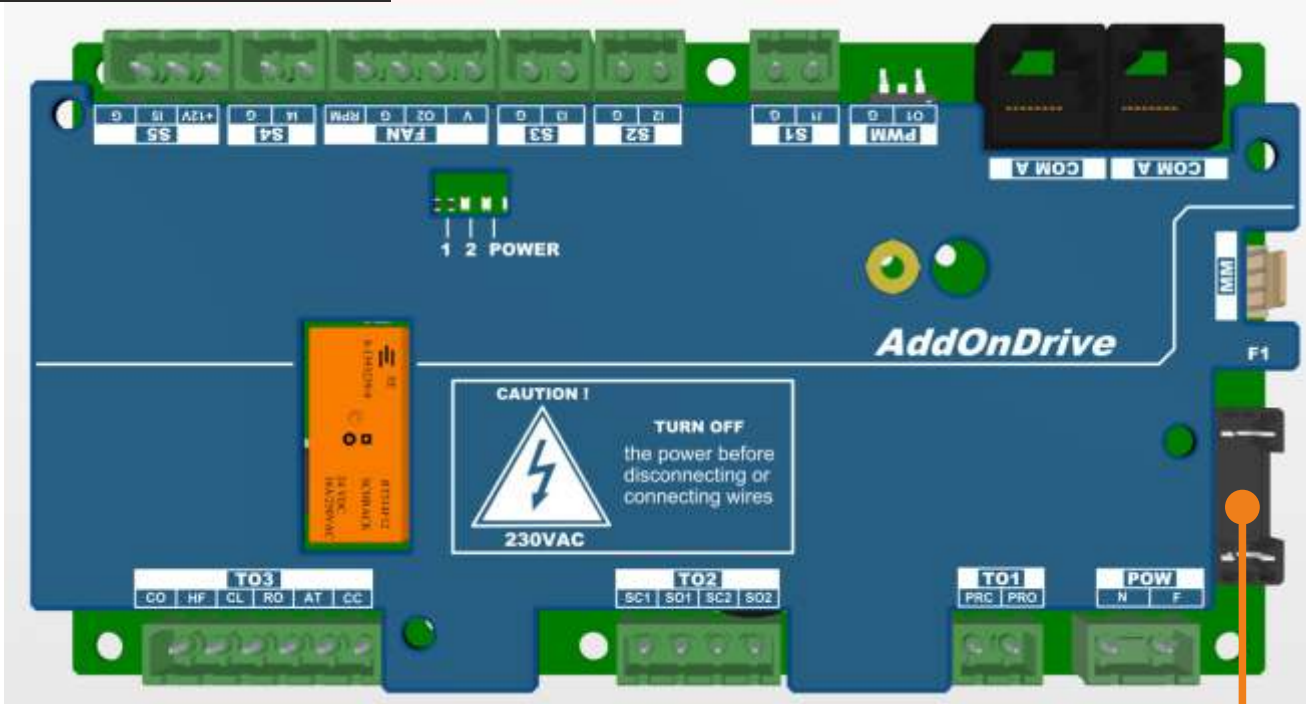

Mark: F1
3,15 A, F

Lambda PCB: LC-21-GS V1 (22995XXXXXXXX "G")

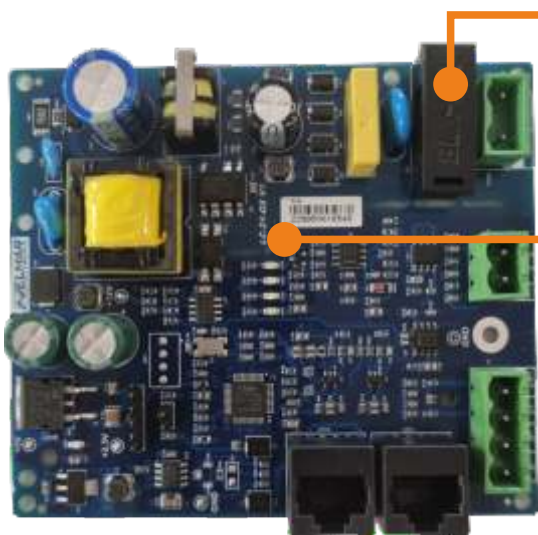

Mark: F1
3,15 A, F

label board:
LC-21-GS V1
(22995XXXXXXXX "G")

MODULE for control of the vacuum suction system: **MODULE CVT** (PCB CMVAC-G)

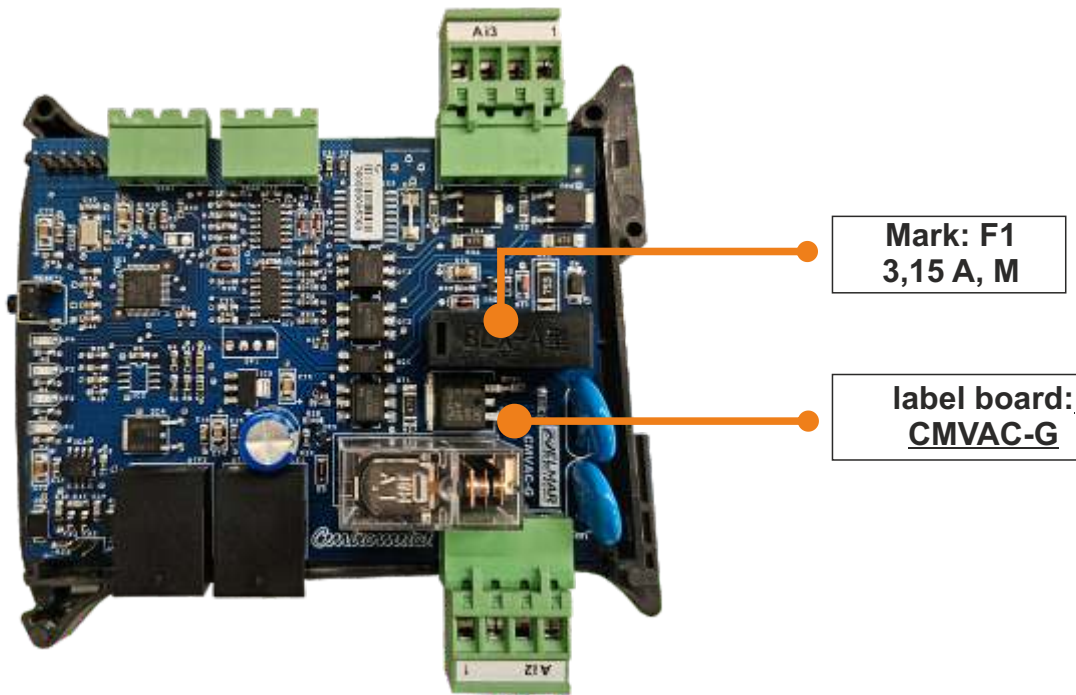

Position of the MODULE CVT for control the Vacuum suction system:

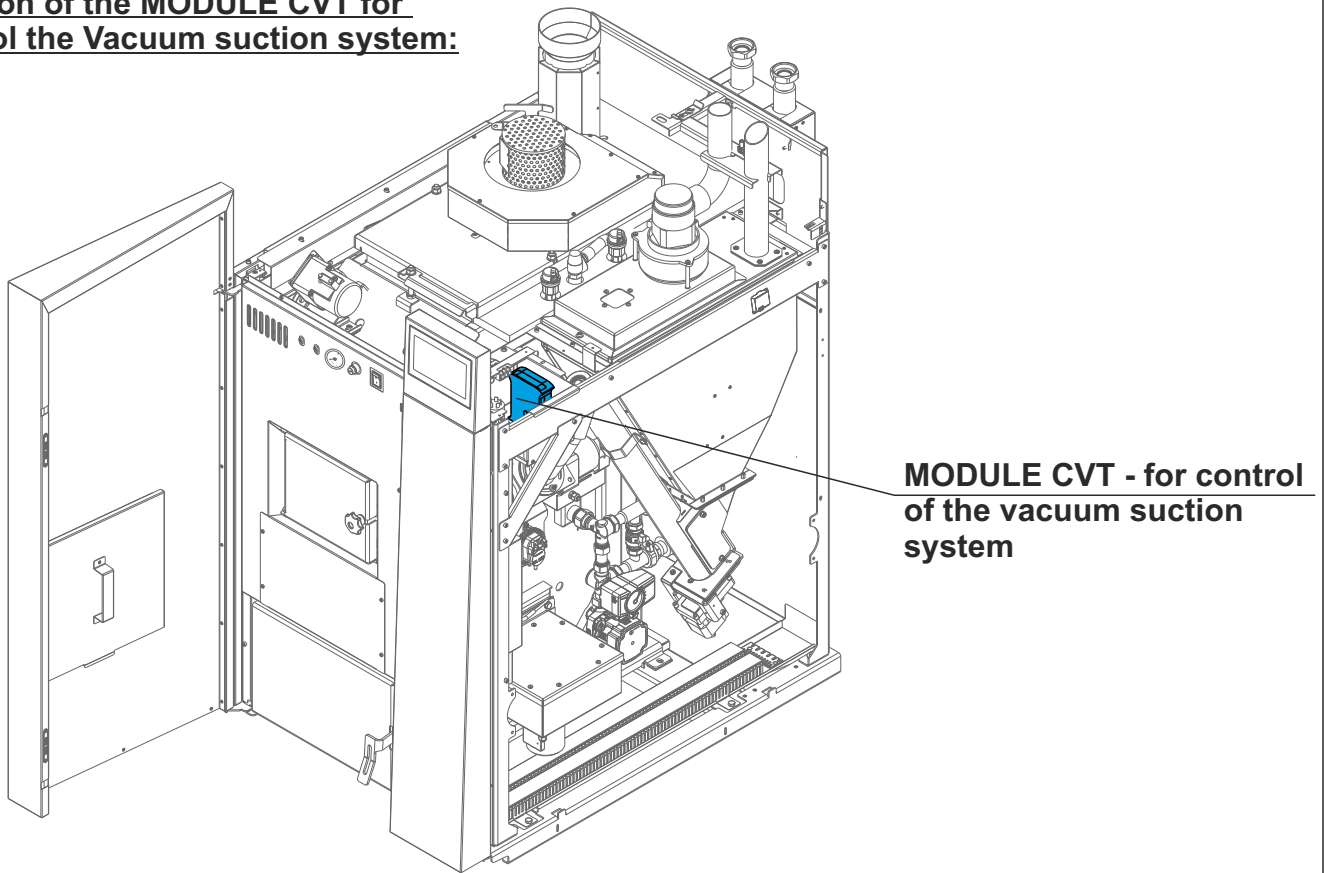

Main fuses / PCB (printed circuit board) positions

Main PCB: UniDrive

MARK	FUSE	DEVICES
F1	3,15 A, F	- Pumps P1, P2, P3, P4 (max = 3 A) - UniDrive PCB power supply
F2	5,0 A, F	- Turbulators motor - Electric heater - Flue gas fan (with RPM sensor) - Mixing valve (boiler circuit) - Grate cleaning mechanism motor - P(PWM) - (Boiler circuit) - Pellet feeder motor - Mixing valve 1

Additional PCB: AddOnDrive

MARK	FUSE	DEVICES
F1	3,15 A, F	- Rotary valve (RSE) - Ash extraction mechanism - motor - AddOnDrive PCB power supply

Lambda PCB: LC-21-GS V1 (22995XXXXXXXX "G")

MARK	FUSE	DEVICES
F1	3,15 A, F	- Lambda probe heater - Lambda probe PCB power supply

MODULE CVT (PCB CMVAC-G):

MARK	FUSE	DEVICES
F1	3,15 A, M	- Pellet feeder screw suction system or Mole suction system

Main fuses:

MARK	FUSE	DEVICES
F3	10,0 A, M	- Main fuse (all PCB with devices)
F4	6,3 A, M	- Pellet suction system

Note:

Acting fuses:

M = Medium Acting Fuse (Mitteltrage)

F = Fast Acting Fuse (Flink)



IMPORTANT: When replacing a fuse, be sure turn OFF the boiler at the main switch and unplug the power cord.

7.2. FASTENING OF INPUT/OUTPUT CABLES

All input/output cables (230 V and low voltage) must be fastened in the "Place for fastening of input cables".

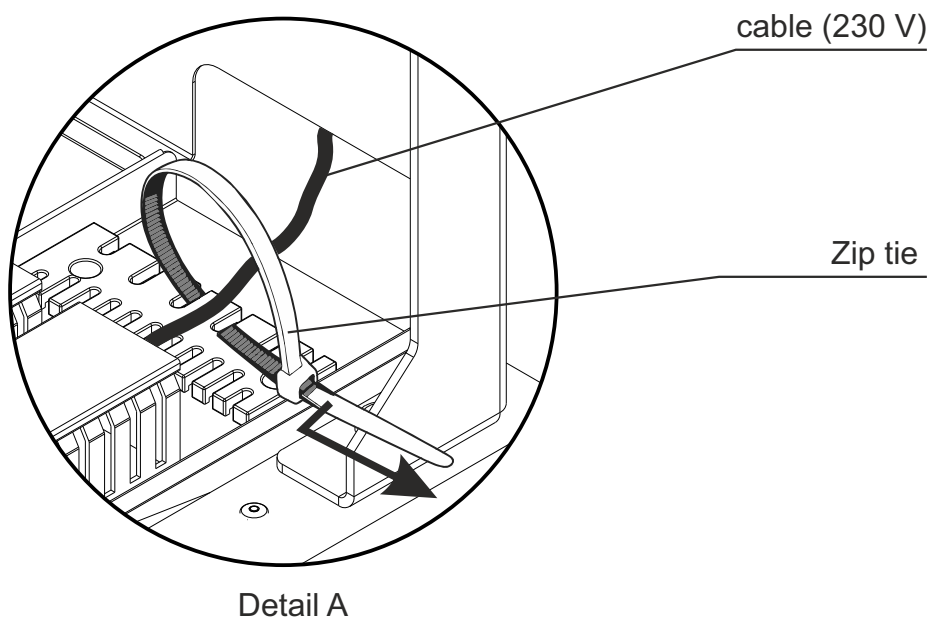
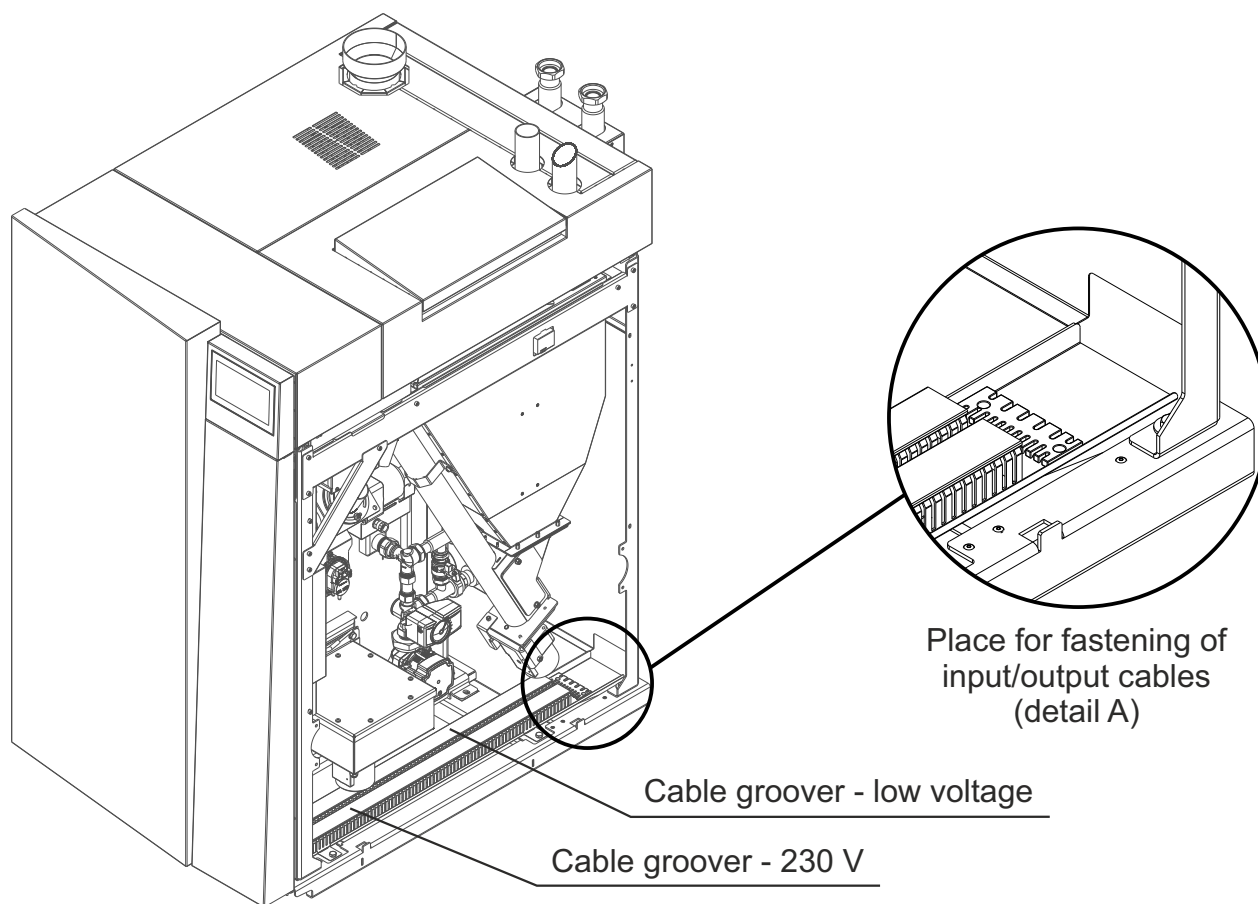

7.3. CONNECTING ADDITIONAL EQUIPMENT CM2K AND CM-NET TO THE BOILER

One of the additional equipment devices (CM2K or CM-NET) is connected with a UTP cable to the UTP connector in the MODULE CVT, and the other devices (if any) are connected with a UTP cable to the previously connected device.

To connect an additional equipment device (CM2K or CM-NET) to the MODULE CVT, you need: (see figure 11):

1. remove the MODULE CVT from its place
2. connect the UTP cable to the place of the free UTP connector
3. return the MODULE CVT to its place.

Figure 11. Remove the MODULE CVT from its place

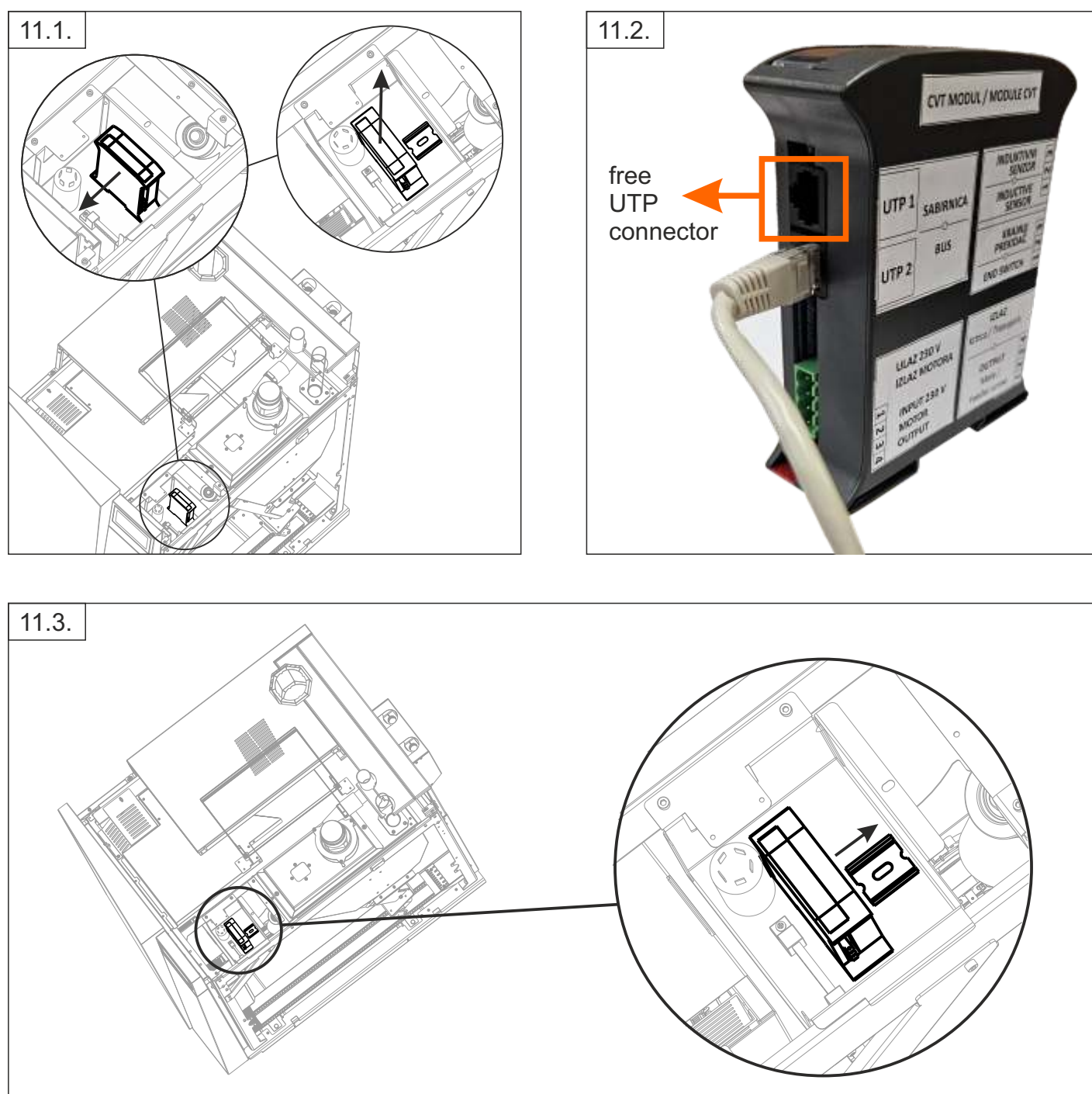

7.4 ELECTRICAL SCHEME INSTALLATION - PelTec-Compact 12

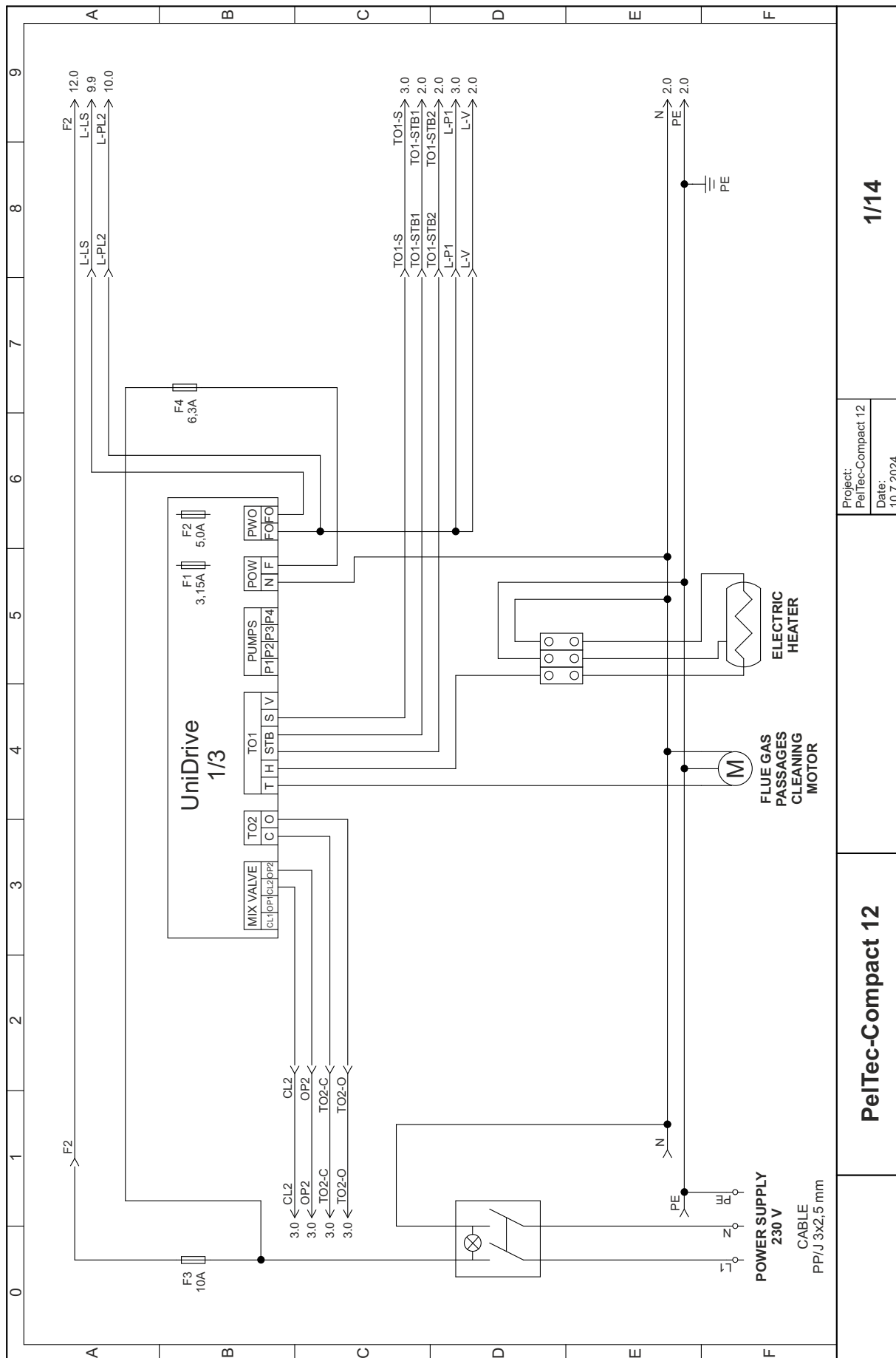

Project:
PelTec-Compact 12
Date:
10.7.2024.

1/14

PelTec-Compact 12

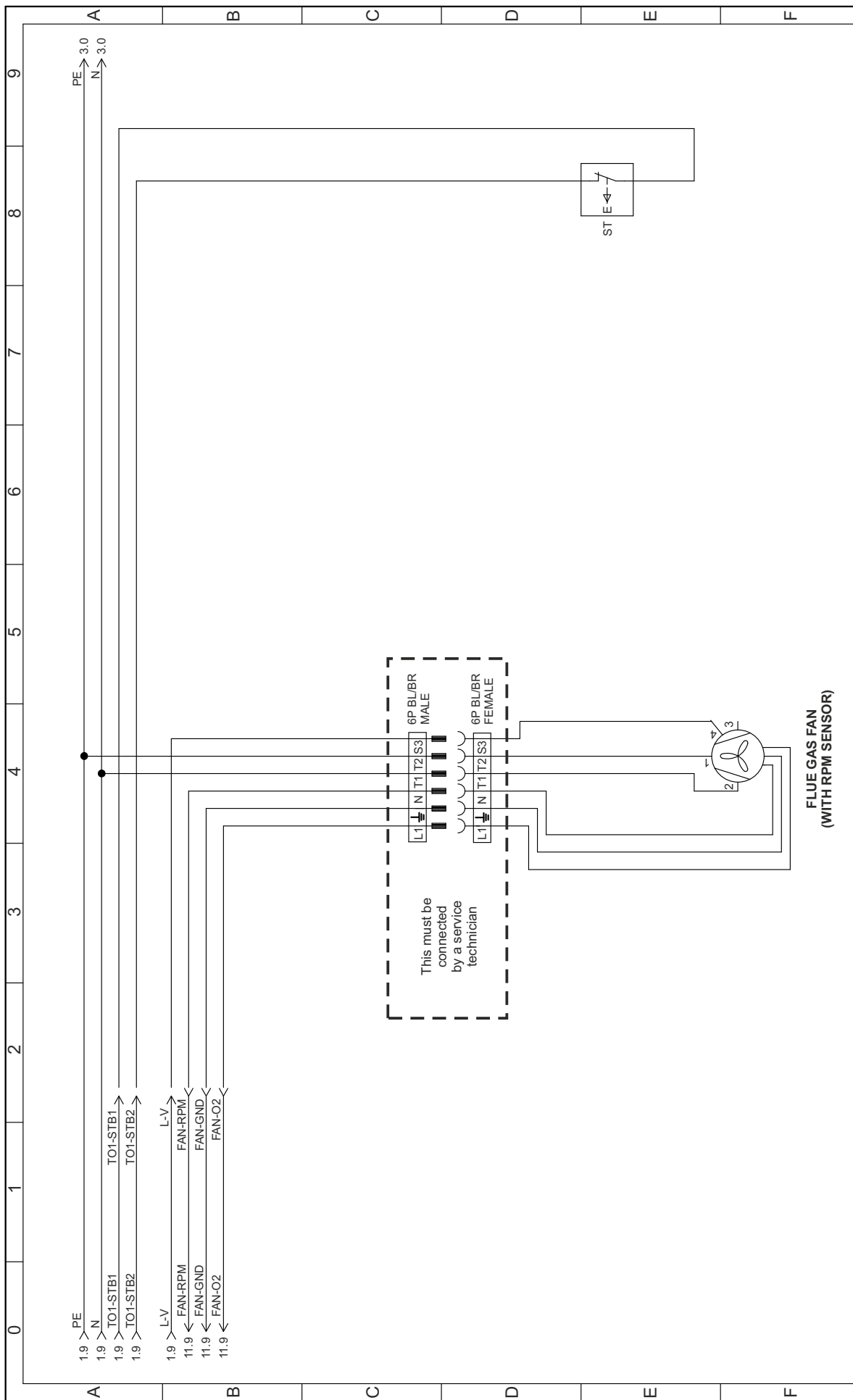

Project:
PeITec-Compact 12
Date:
10.7.2024.

2/14

PeITec-Compact 12

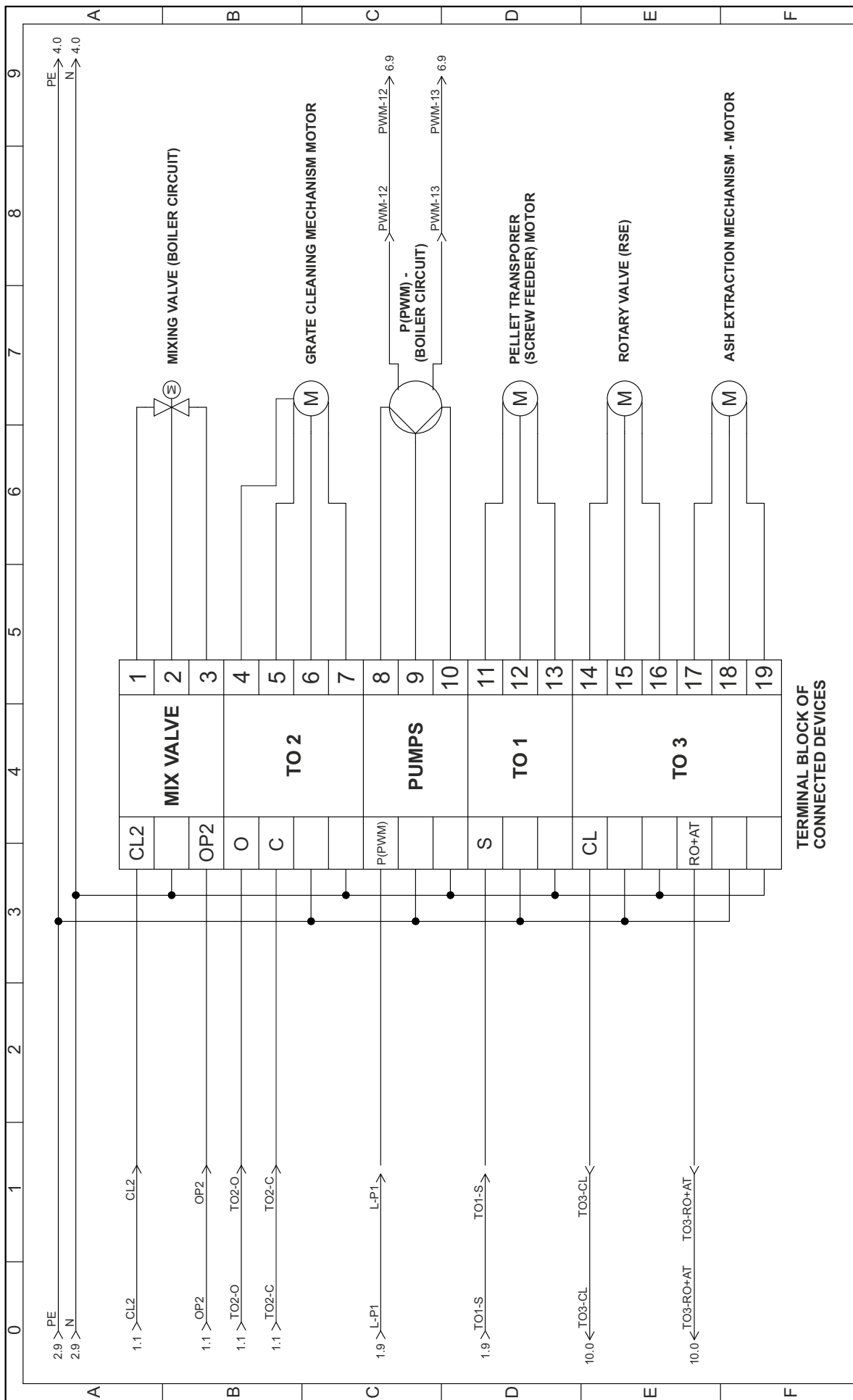

PelTec-Compact 12	3/14
	Projekt: PelTec-Compact 12 Datum: 10.7.2024.

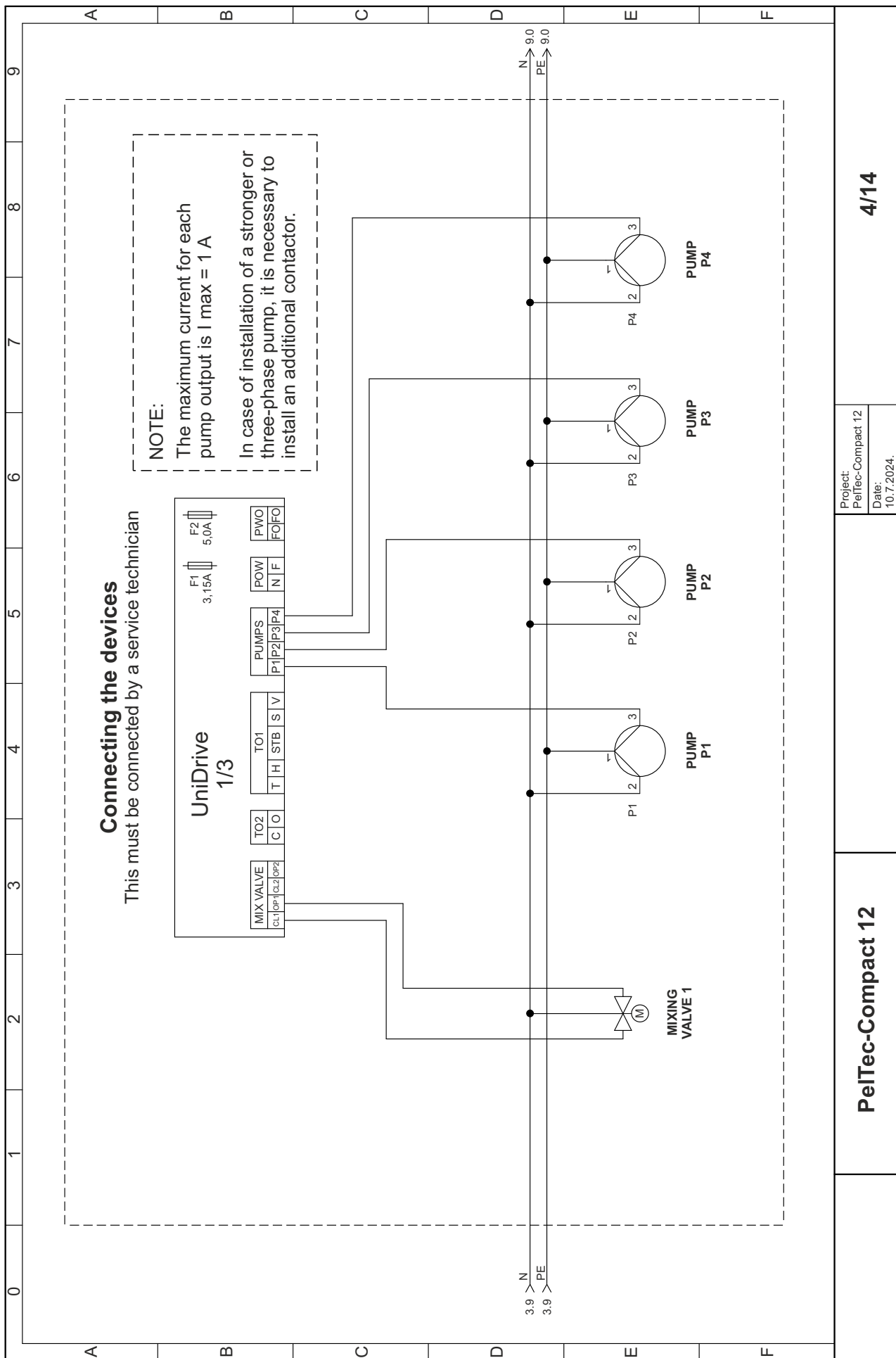

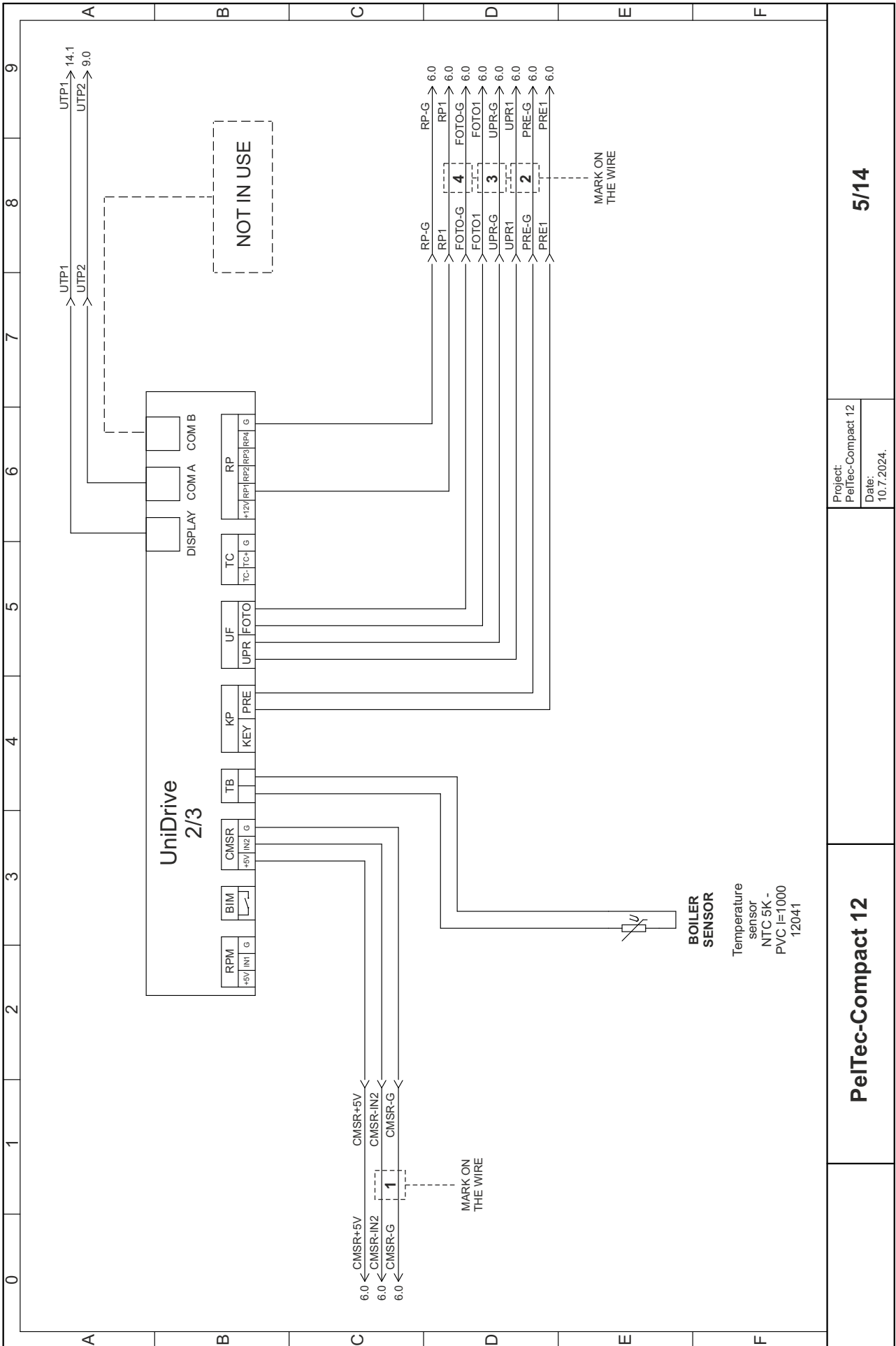

Project:
PelTec-Compact 12
Date:
10.7.2024.

PelTec-Compact 12

5/14

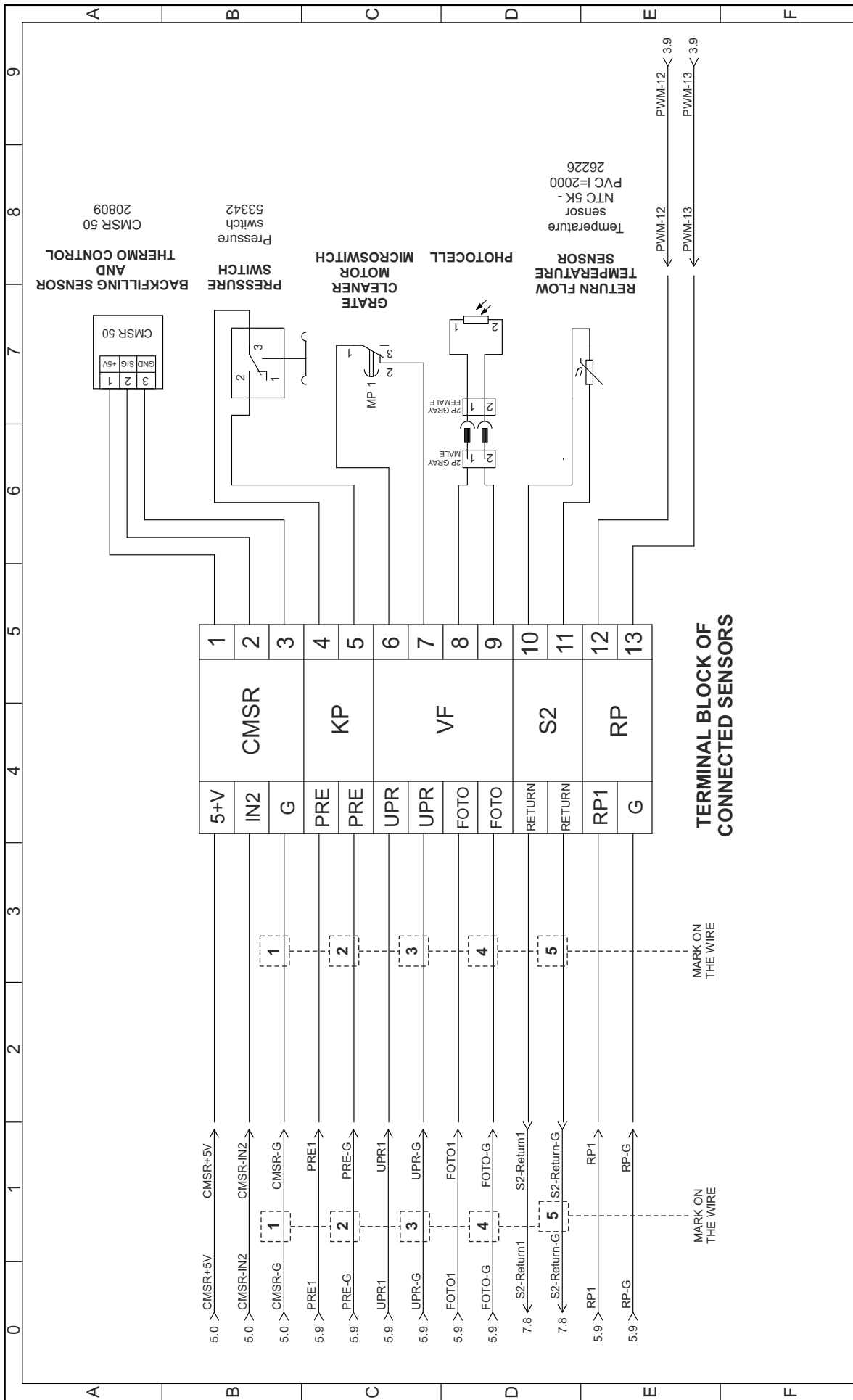

TERMINAL BLOCK OF CONNECTED SENSORS

Project: PeITec-Compact 12
Date: 10.7.2024.

6/14

PeITec-Compact 12

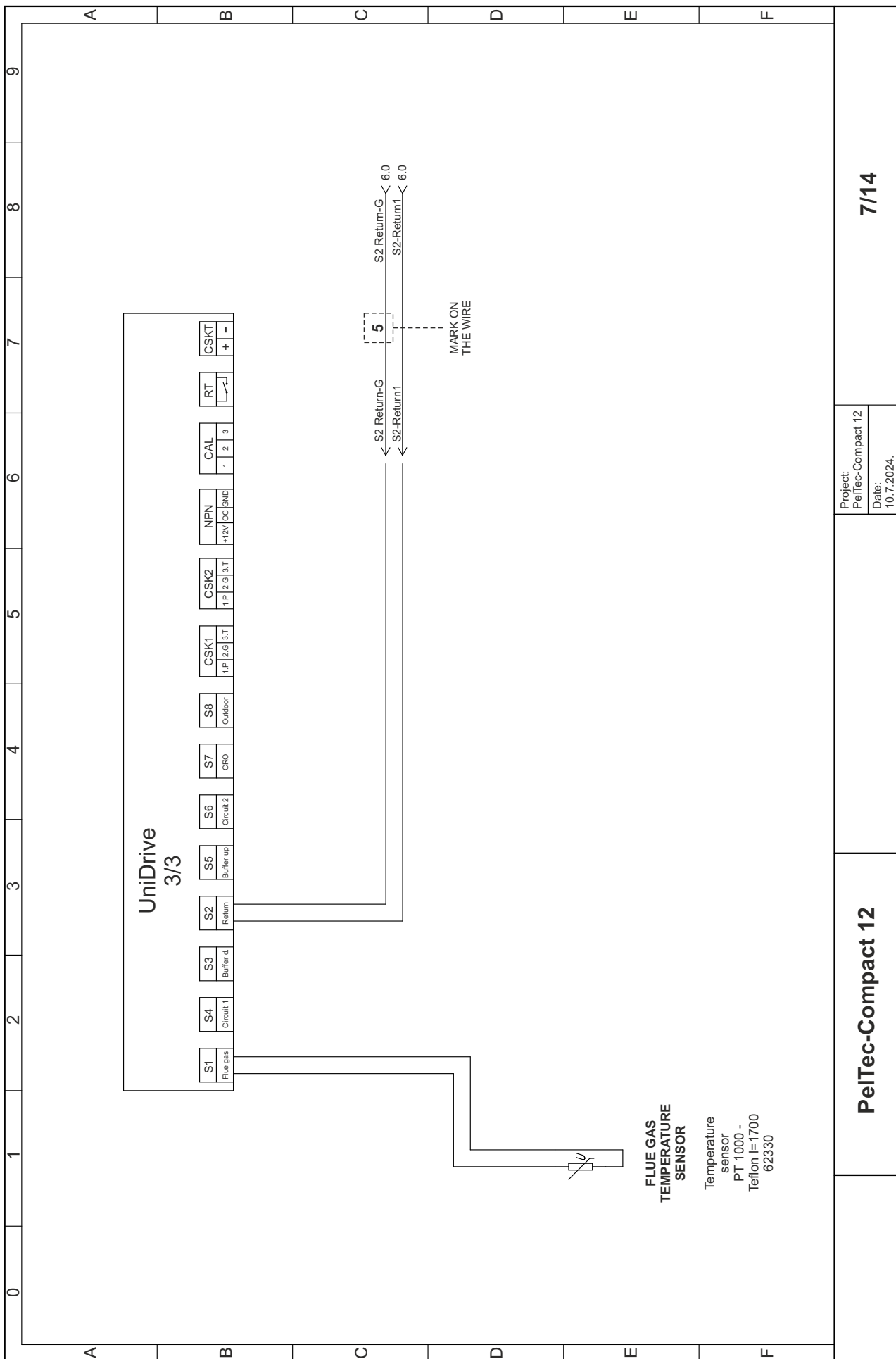

Project:
PelTec-Compact 12
Date:
10.7.2024.

7/14

PelTec-Compact 12

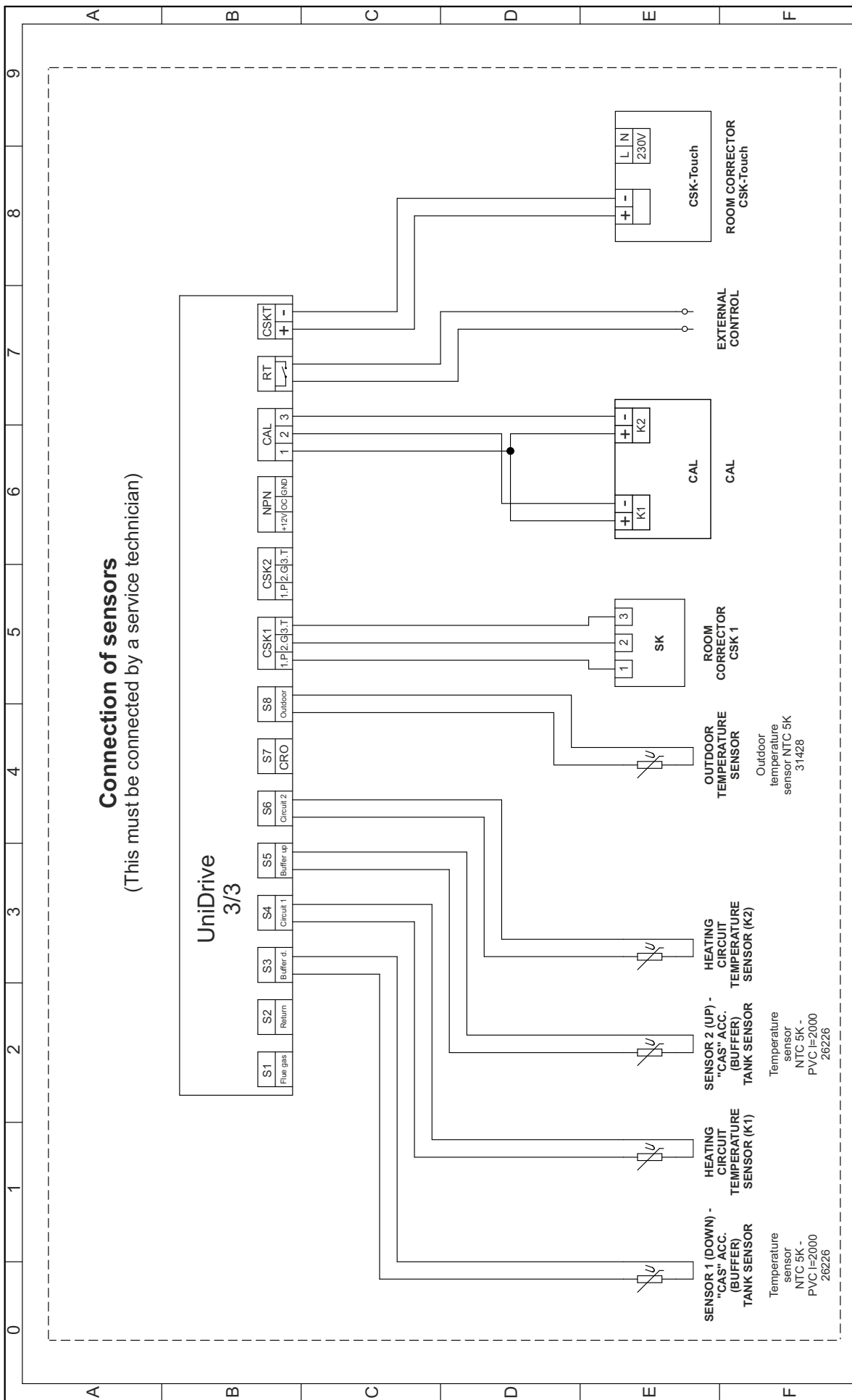

Connection of sensors
(This must be connected by a service technician)

Project: PeITec-Compact 12
Date: 10.7.2024.

PeITec-Compact 12

8/14

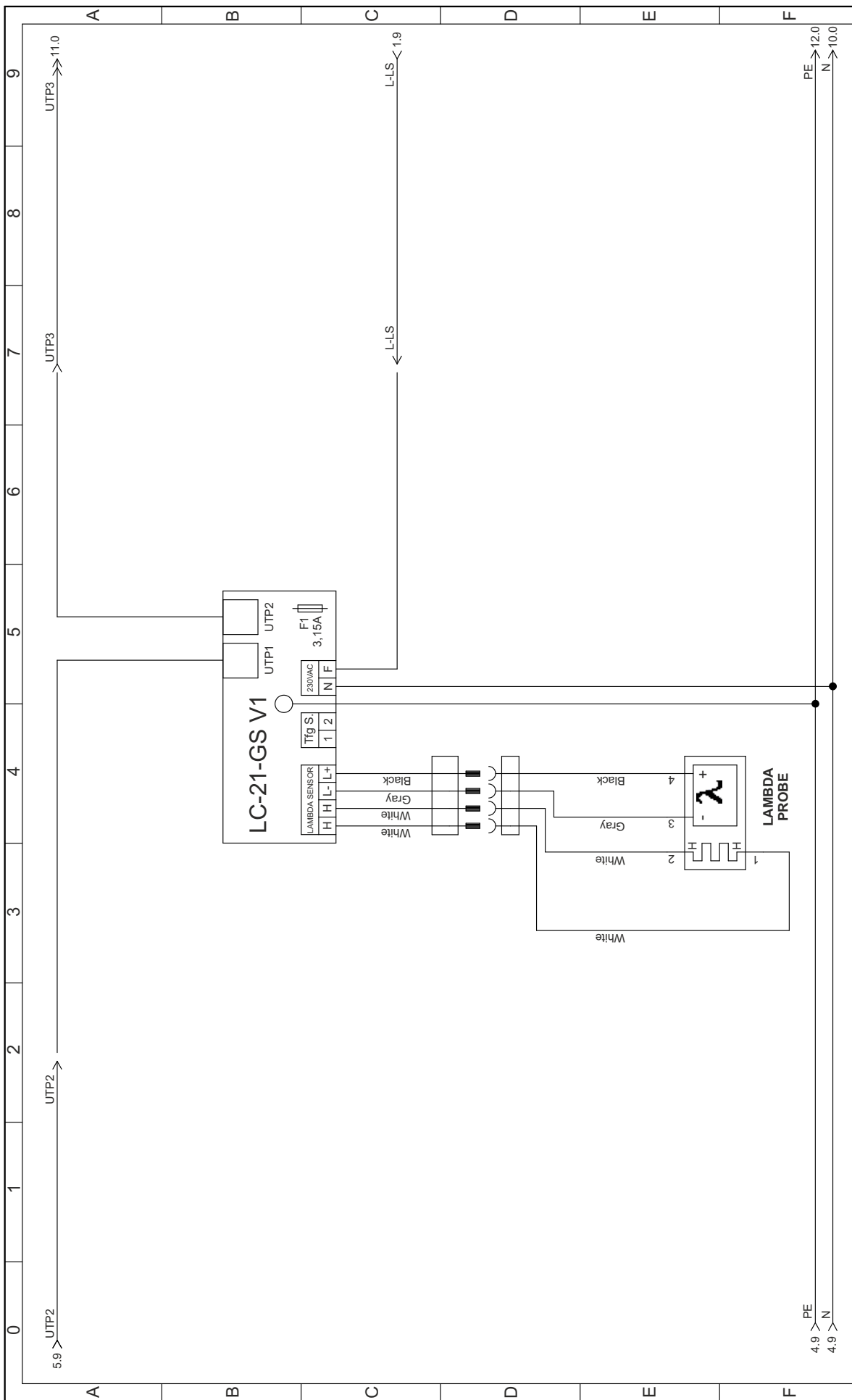

Project:
PeITec-Compact 12
Date:
10.7.2024.

9/14

PeITec-Compact 12

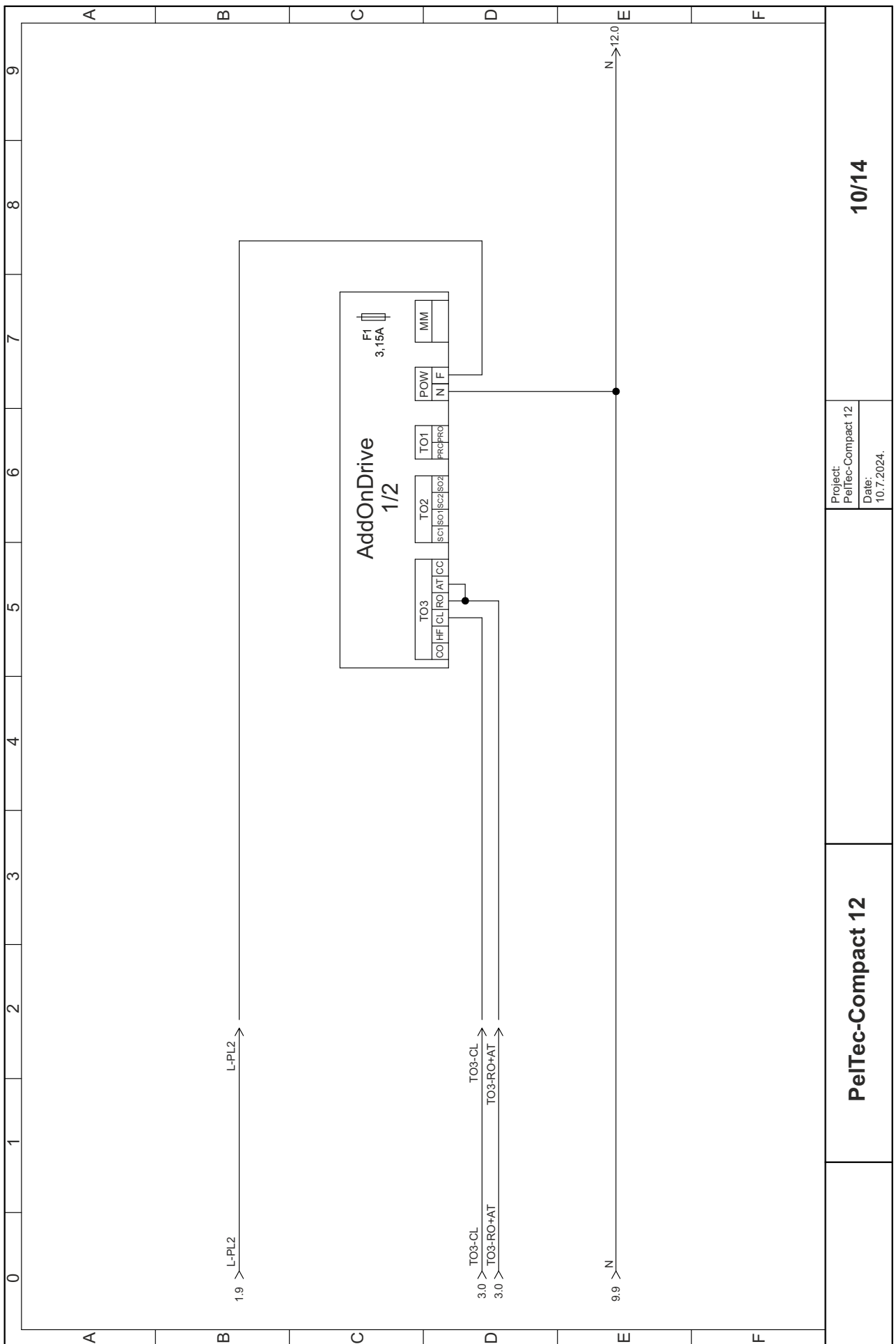

10/14

Project: PeITec-Compact 12
Date: 10.7.2024.

PeITec-Compact 12

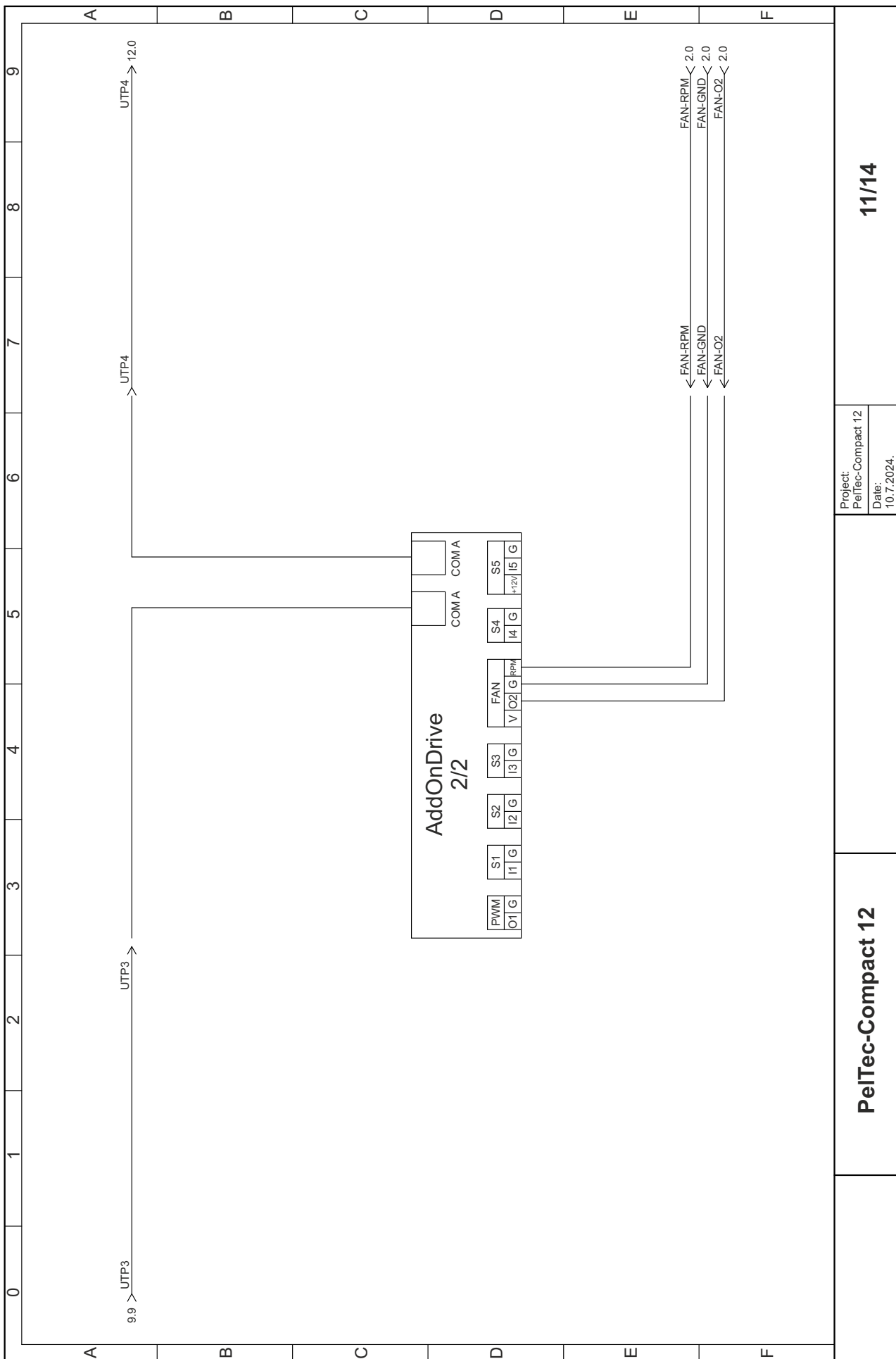

Project:
PelTec-Compact 12
Date:
10.7.2024.

11/14

PelTec-Compact 12

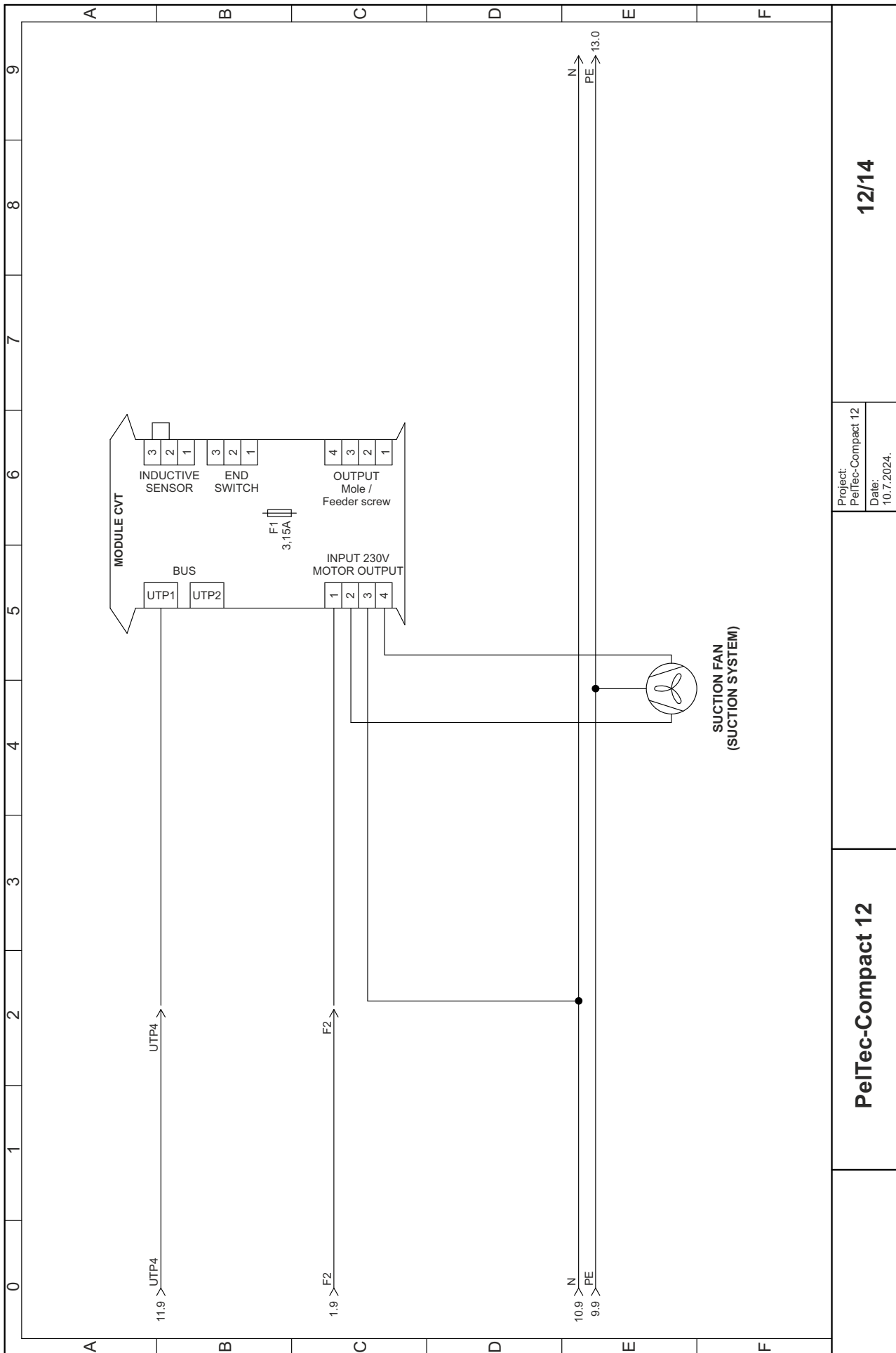

Project:
PeITec-Compact 12
Date:
10.7.2024.

12/14

PeITec-Compact 12

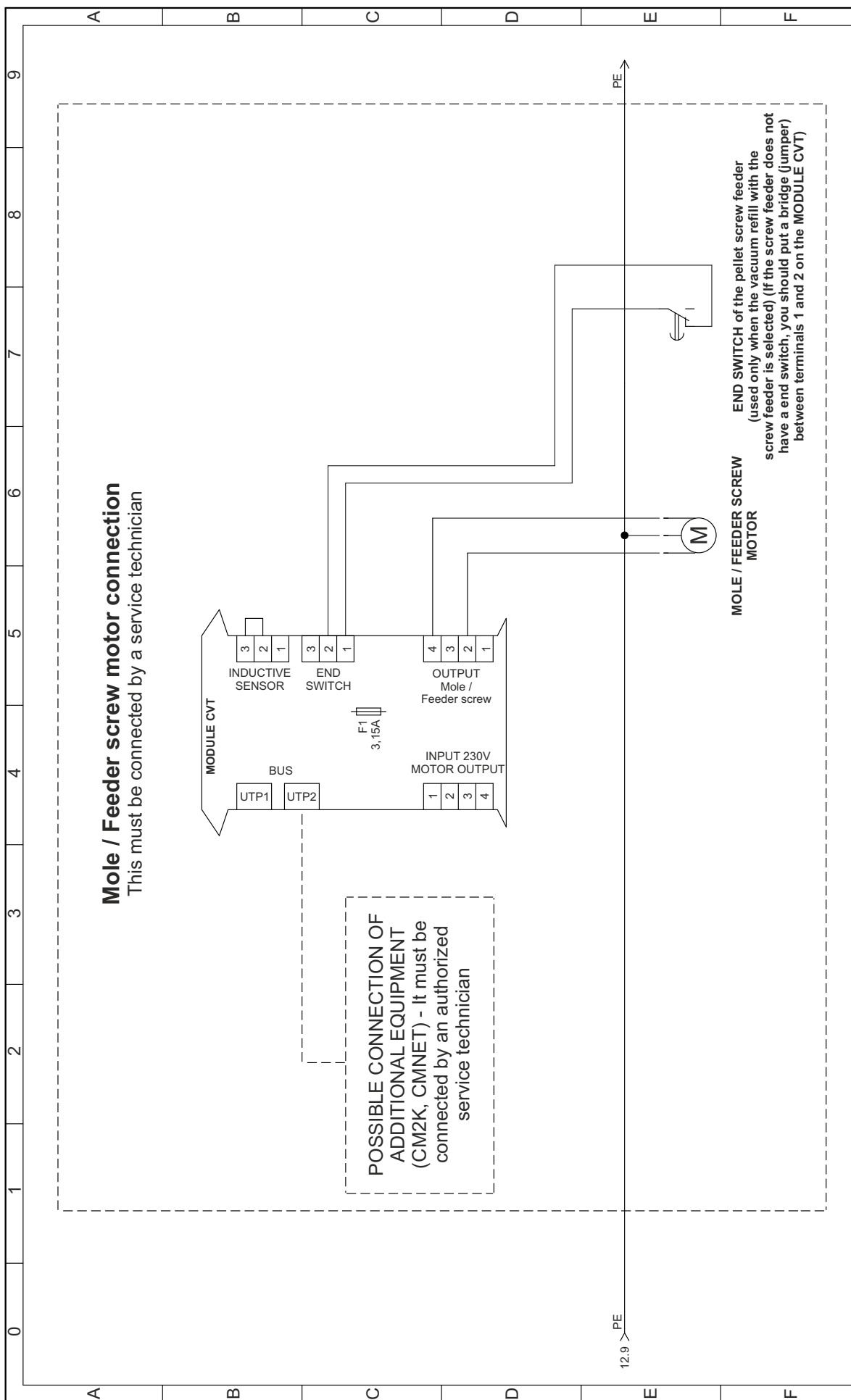

Project:
PelTec-Compact 12
Date:
10.7.2024.

13/14

PelTec-Compact 12

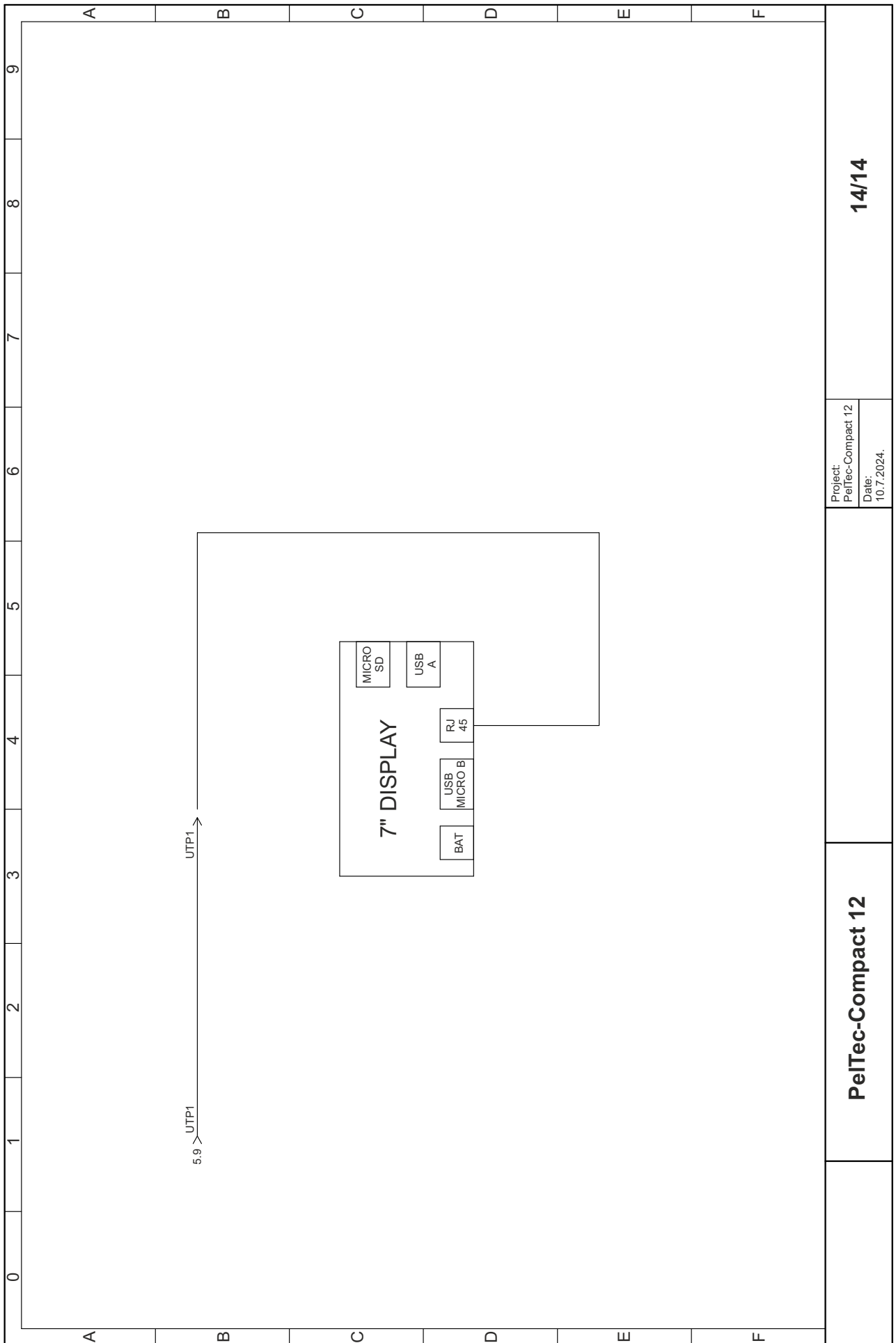

Project:
PeITec-Compact 12
Date:
10.7.2024.

14/14

PeITec-Compact 12

7.5. ELECTRICAL SCHEME INSTALLATION - PeITec-Compact 18/24

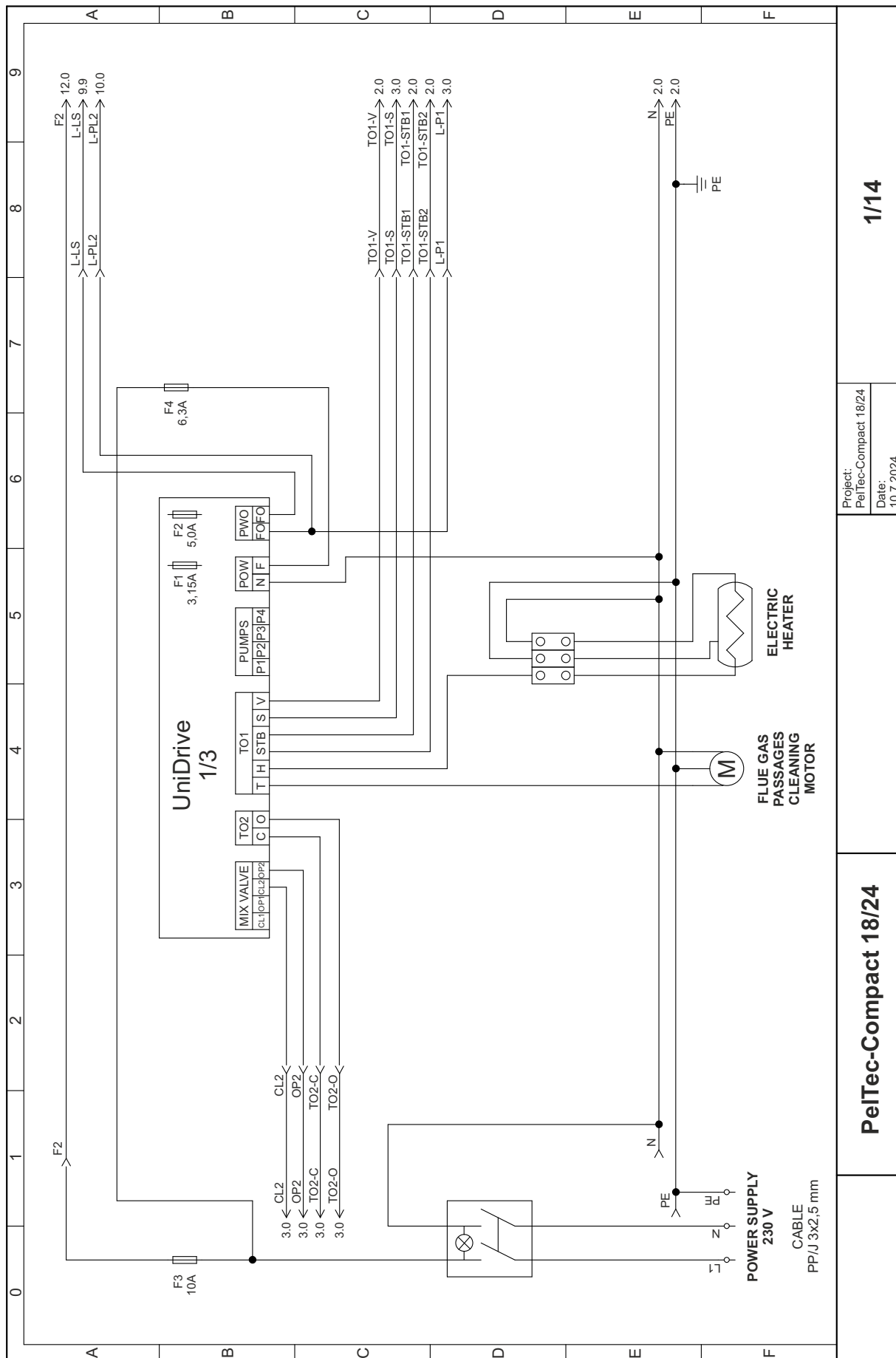

Project:
PeITec-Compact 18/24
Date:
10.7.2024.

PeITec-Compact 18/24

1/14

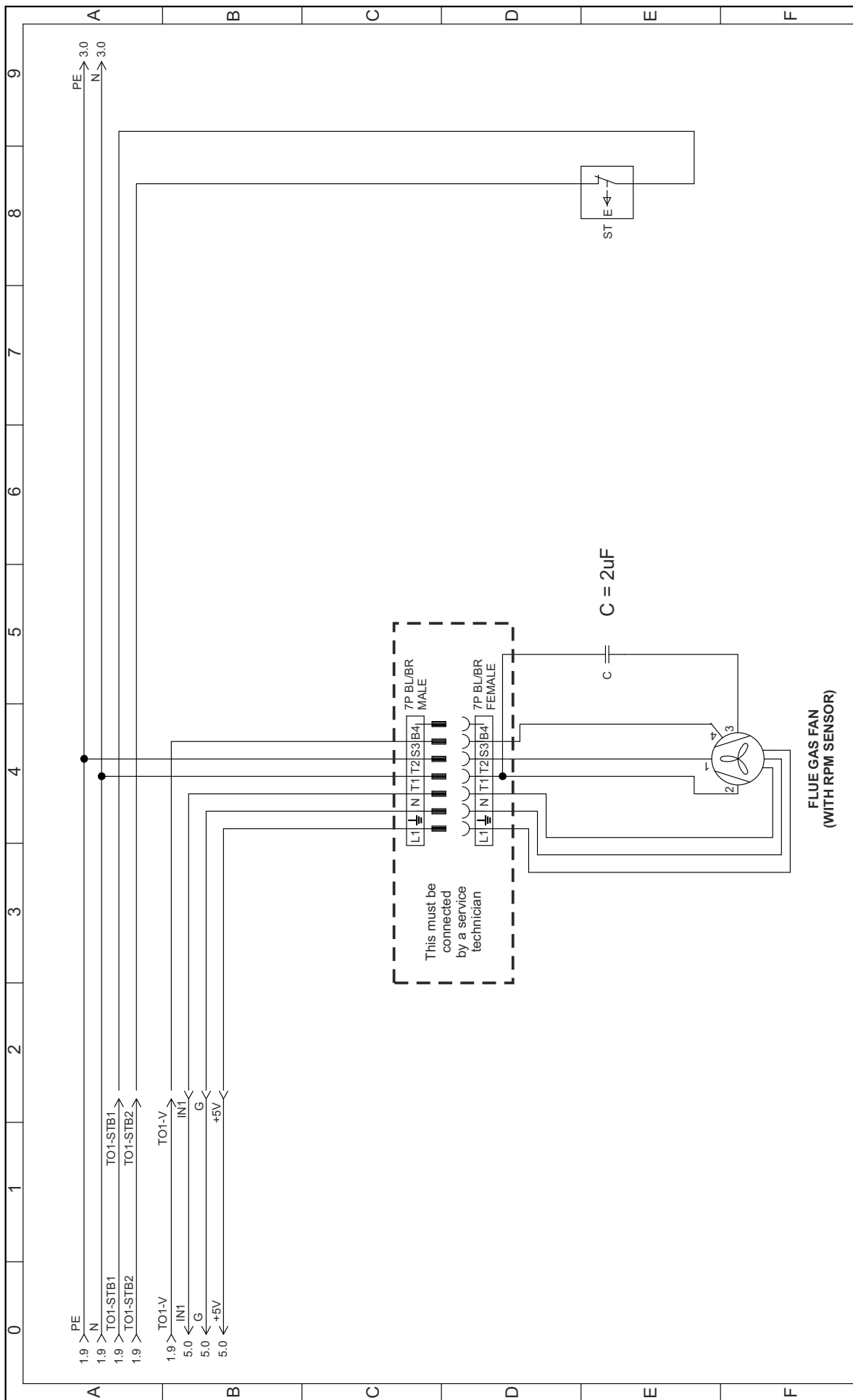

Project:
PeITec-Compact 18/24
Date:
10.7.2024.

2/14

PeITec-Compact 18/24

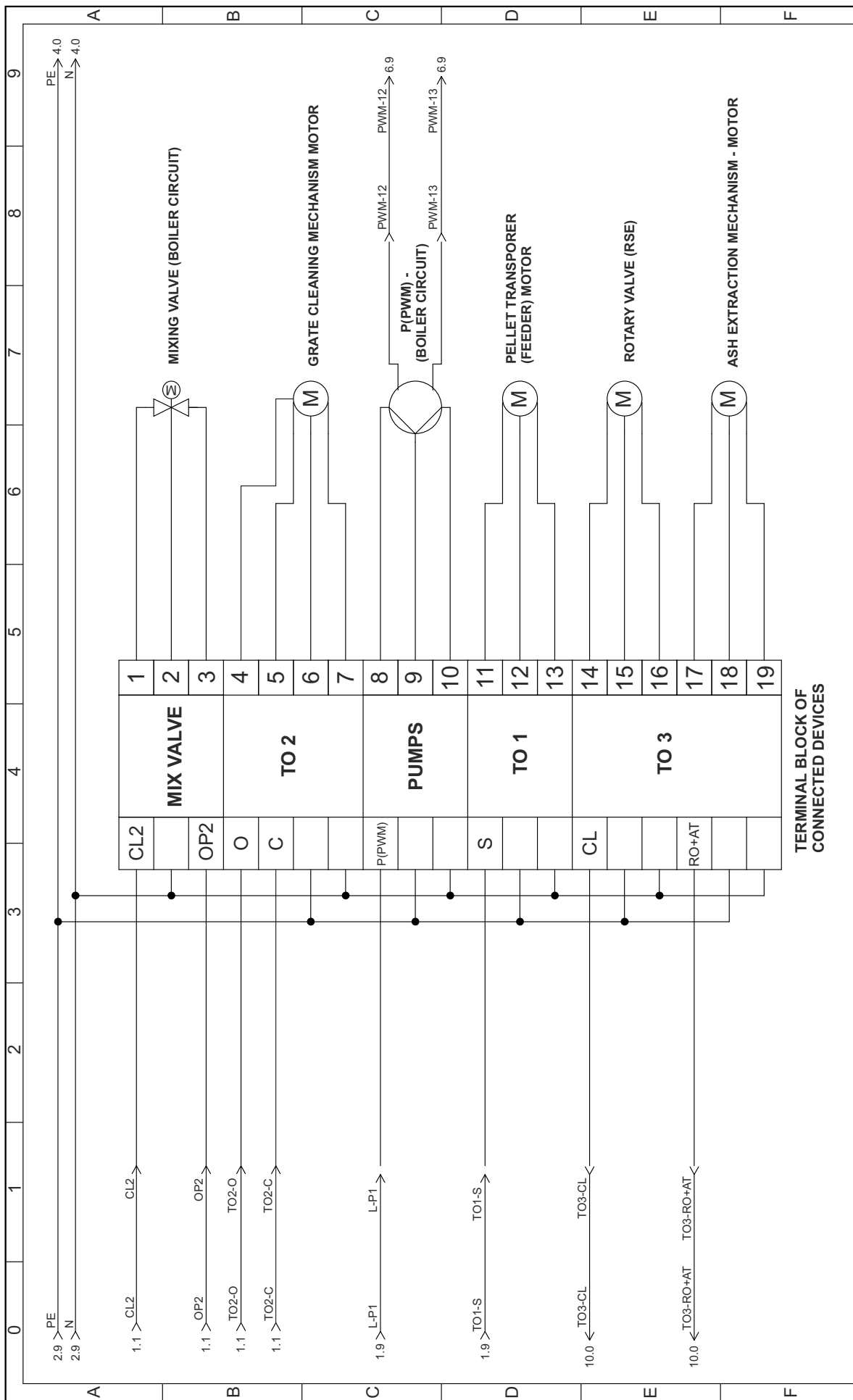

Project:
PelTec-Compact 18/24
Date:
10.7.2024.

3/14

PelTec-Compact 18/24

TERMINAL BLOCK OF
CONNECTED DEVICES

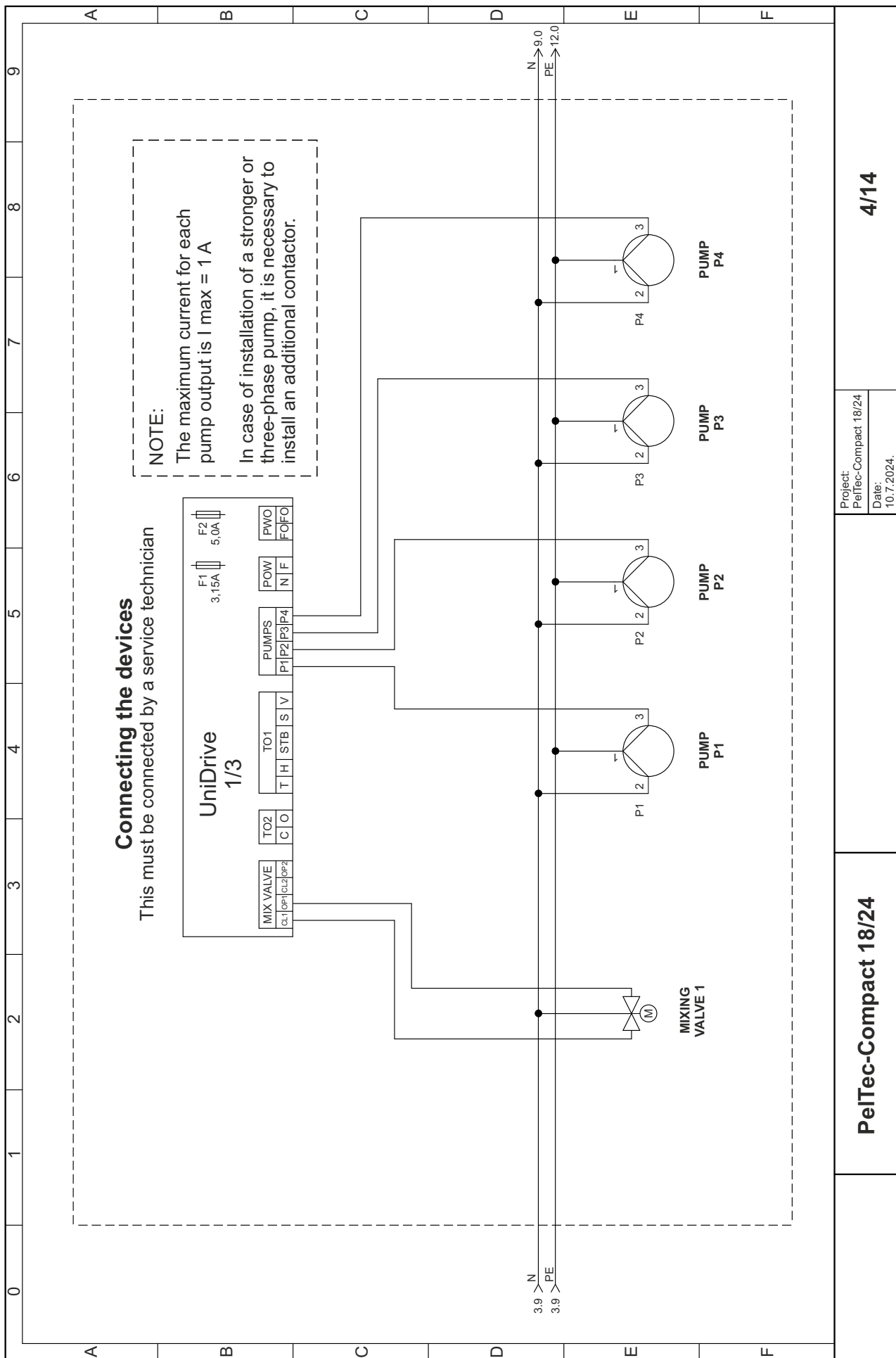

Project:
PeITec-Compact 18/24
Date:
10.7.2024.

4/14

PeITec-Compact 18/24

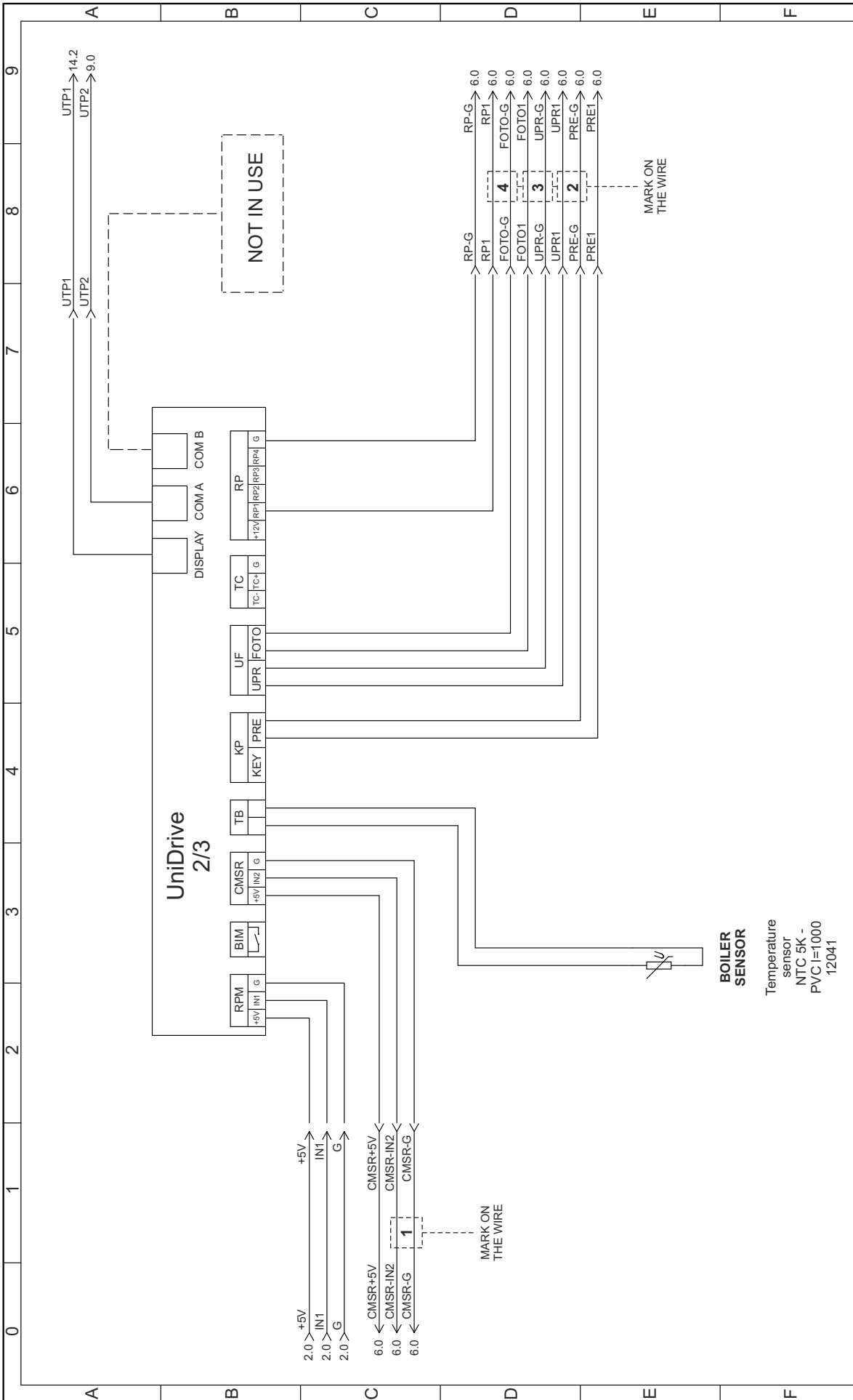

Project:
PelTec-Compact 18/24
Date:
10.7.2024.

5/14

PelTec-Compact 18/24

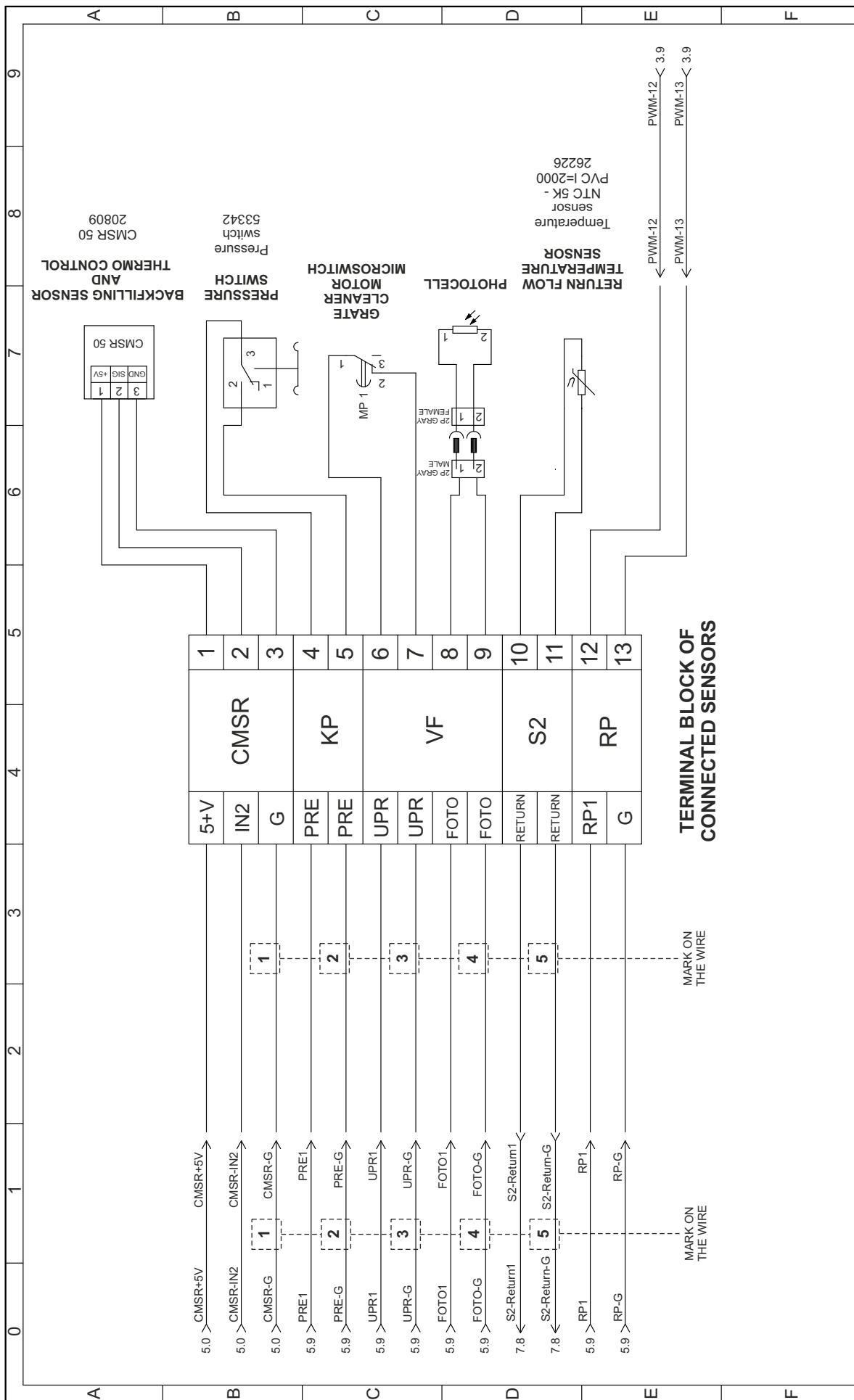

TERMINAL BLOCK OF CONNECTED SENSORS

1	2	3	4	5	6	7	8	9	10	11	12	13
5+V	IN2	G	PRE	PRE	UPR	UPR	FOTO	FOTO	RETURN	RETURN	RP1	G
CMSR			KP		VF			S2		RP		

Project: PeITec-Compact 18/24
Date: 10.7.2024.

6/14

PeITec-Compact 18/24

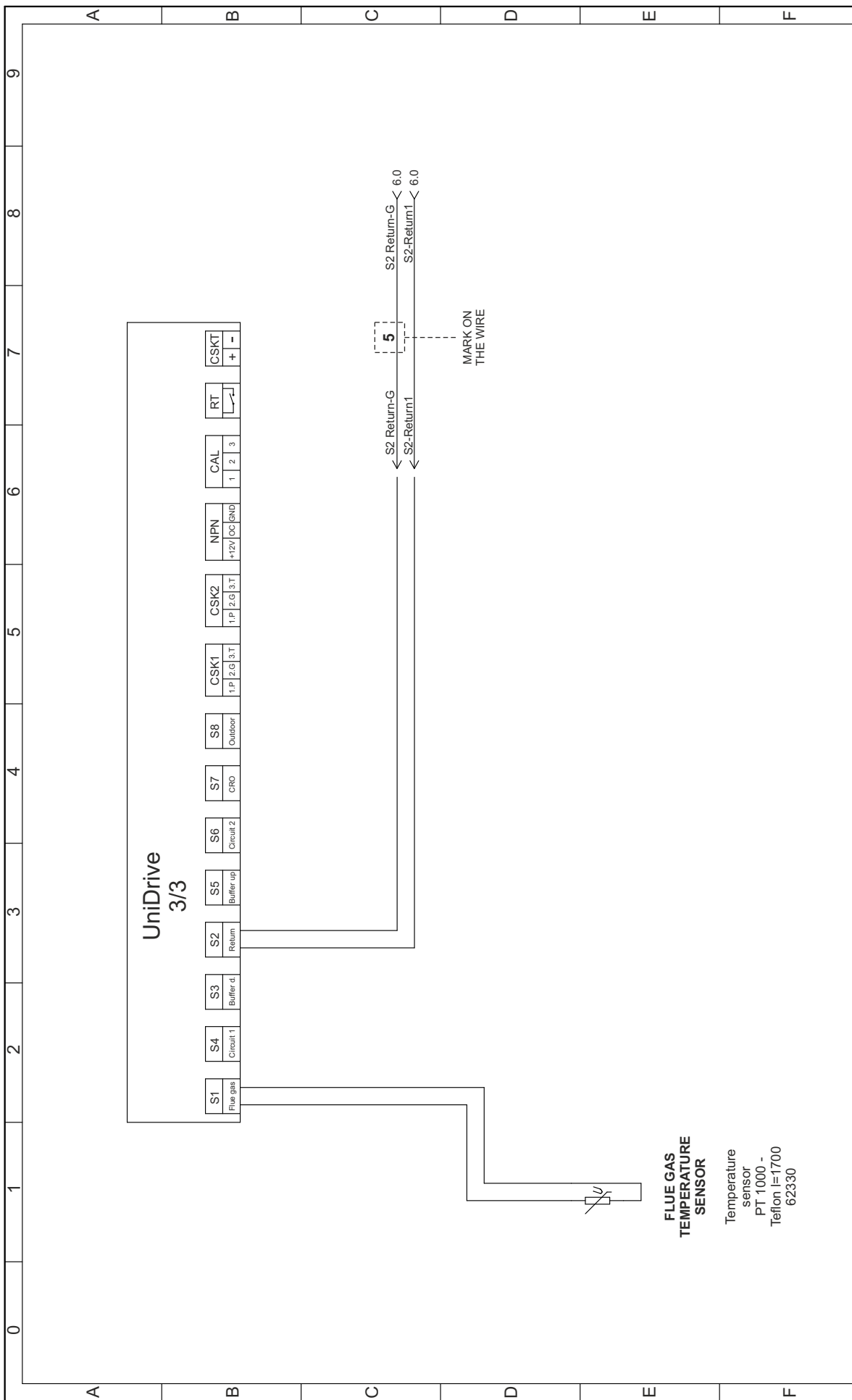

Project:
PelTec-Compact 18/24
Date:
10.7.2024.

7/14

PelTec-Compact 18/24

**FLUE GAS
TEMPERATURE
SENSOR**
Temperature
sensor
PT 1000 -
Teflon I=1700
62330

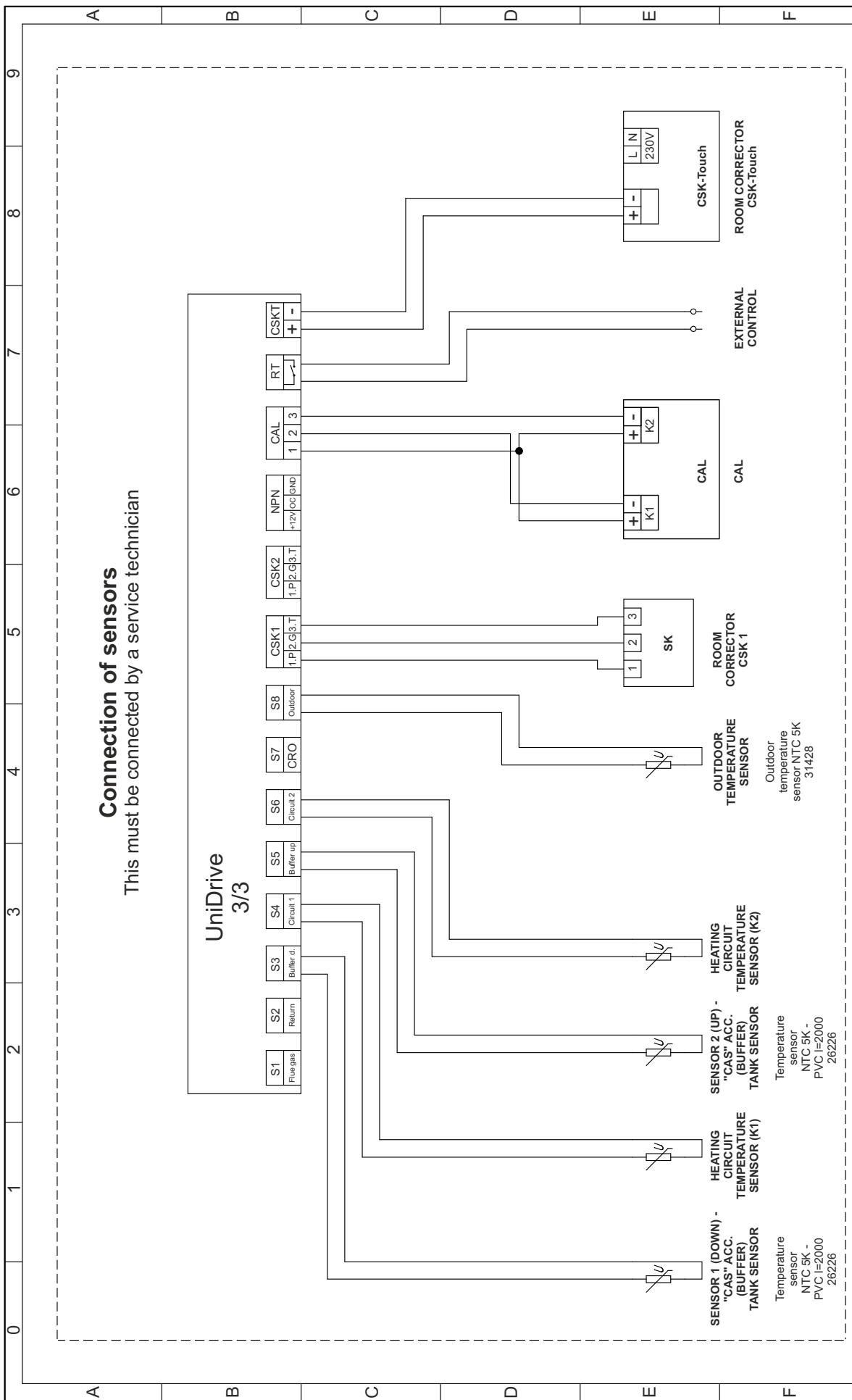

Connection of sensors

This must be connected by a service technician

UniDrive
3/3

8/14

Project:
PelTec-Compact 18/24
Date:
10.7.2024.

PelTec-Compact 18/24

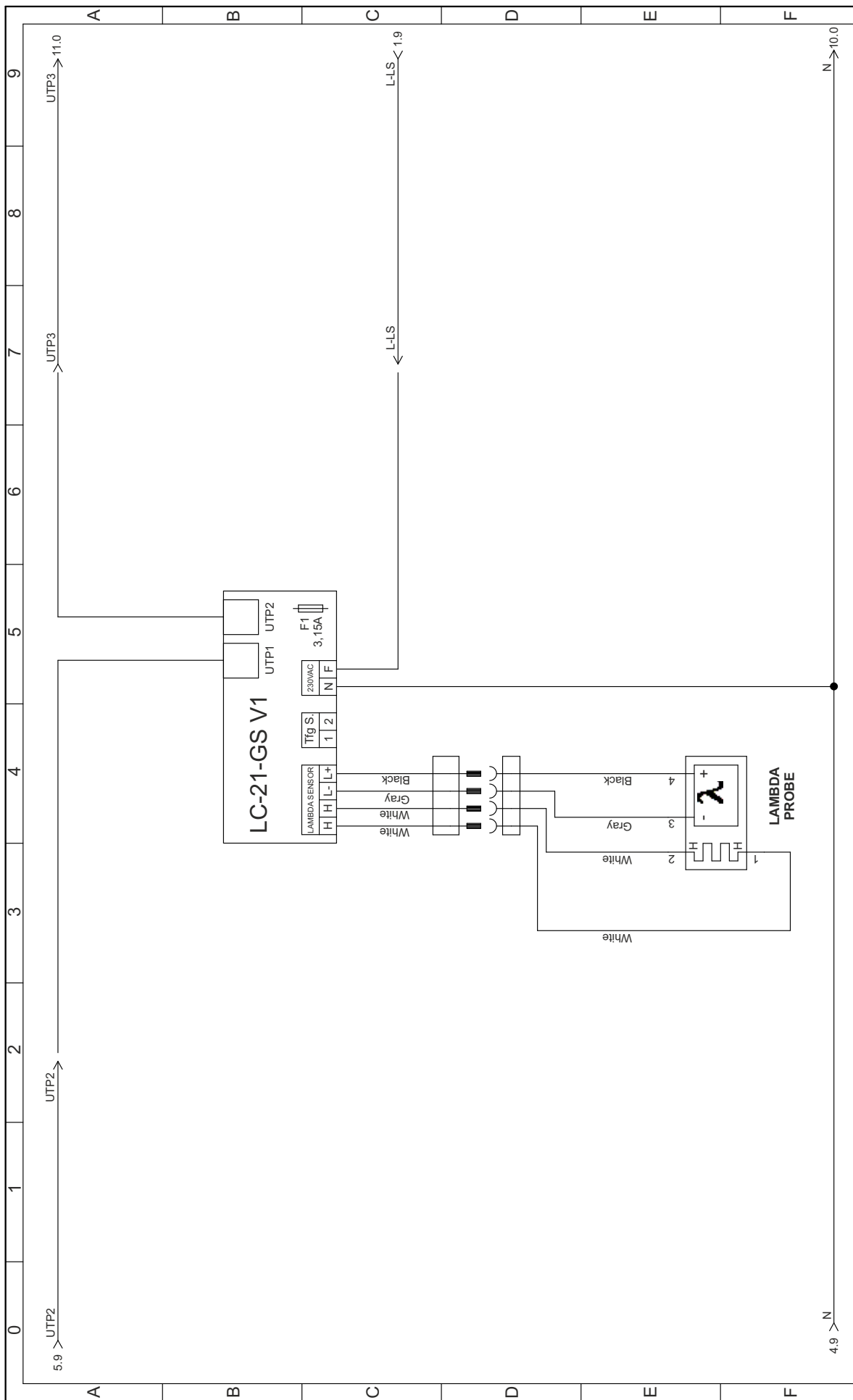

Project:
PeITec-Compact 18/24
Date:
10.7.2024.

9/14

PeITec-Compact 18/24

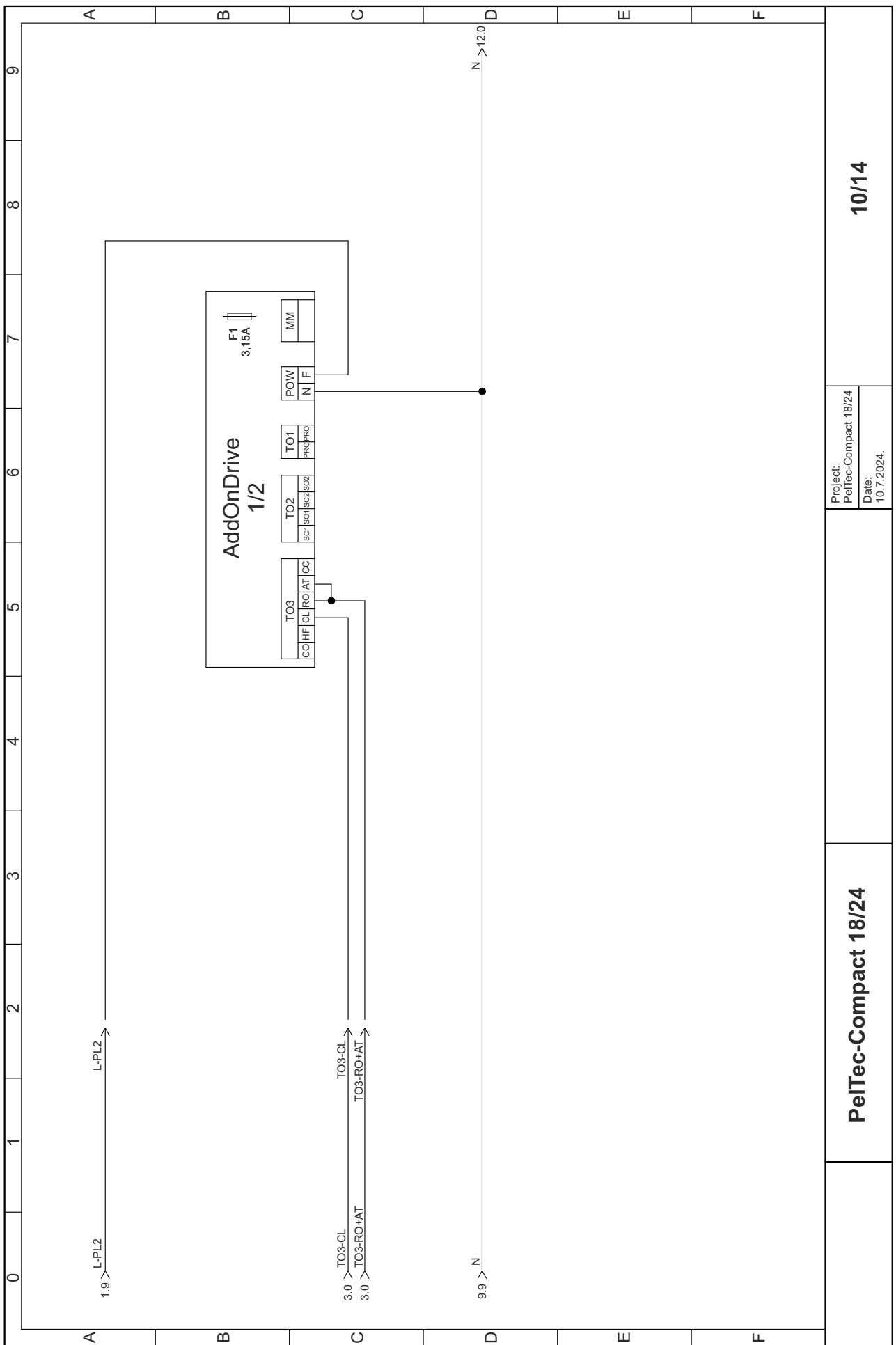

Project:
PeITec-Compact 18/24
Date:
10.7.2024.

10/14

PeITec-Compact 18/24

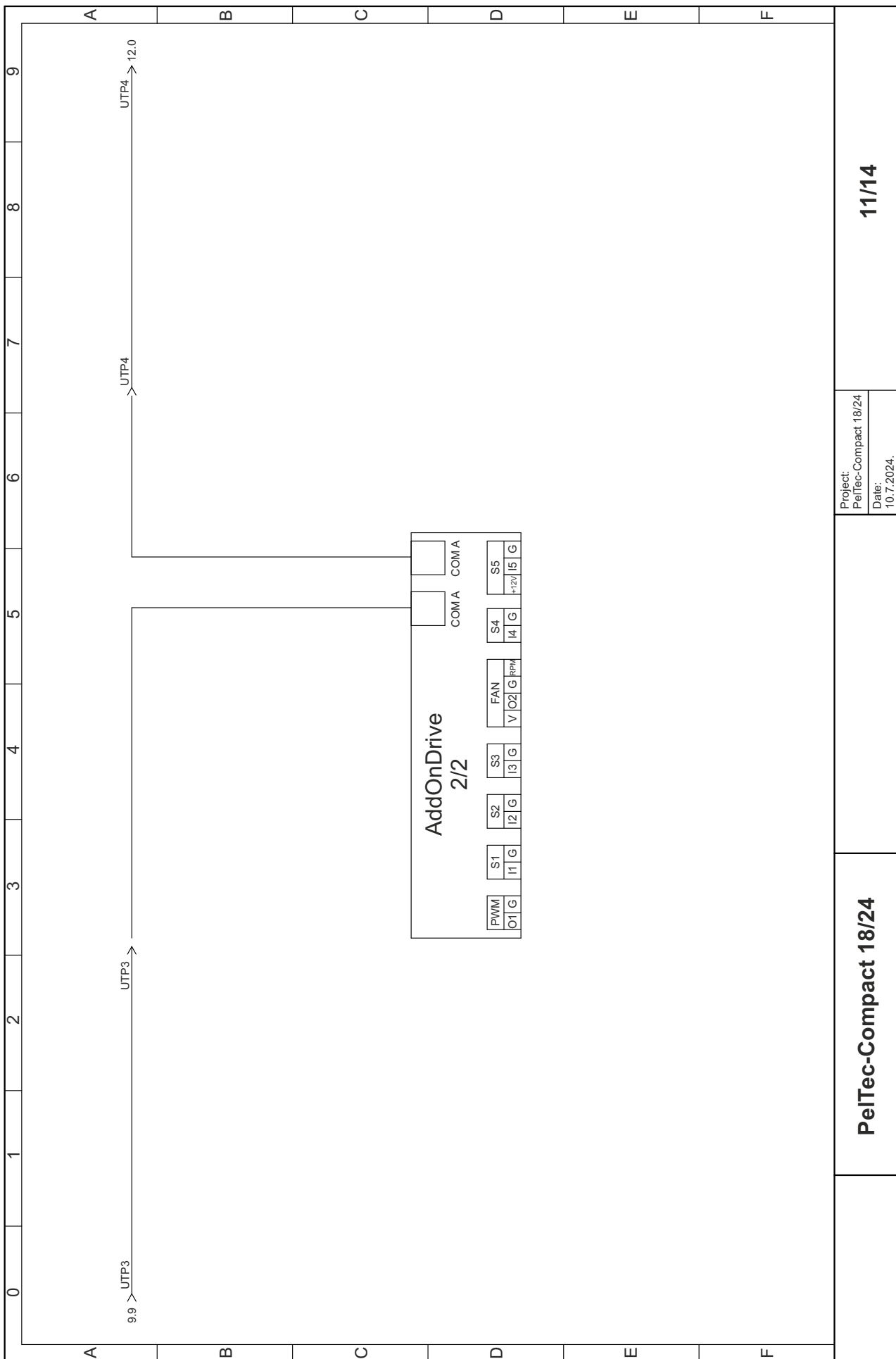

Project:
PeITec-Compact 18/24
Date:
10.7.2024.

11/14

PeITec-Compact 18/24

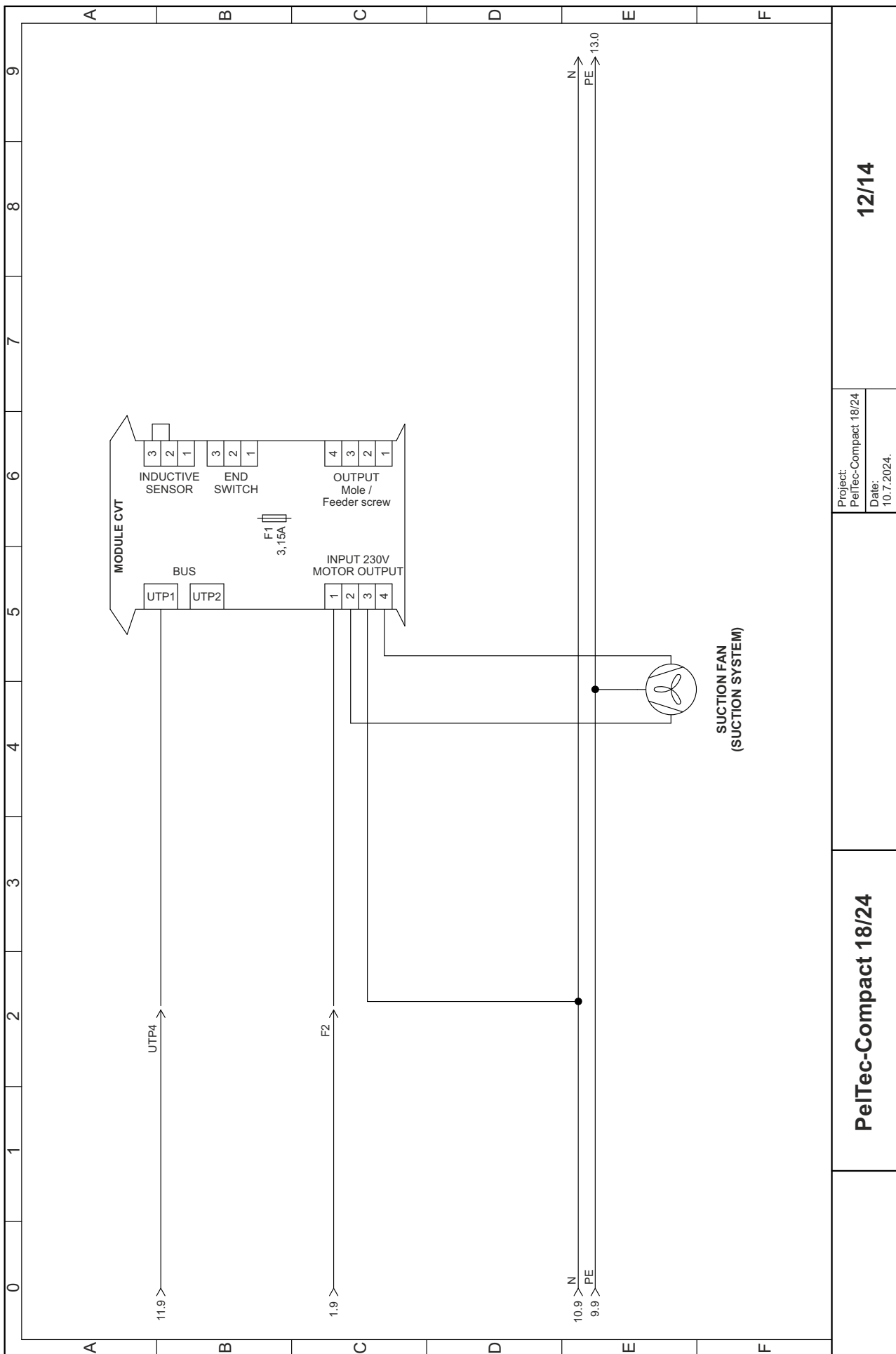

Project:
PeITec-Compact 18/24
Date:
10.7.2024.

12/14

PeITec-Compact 18/24

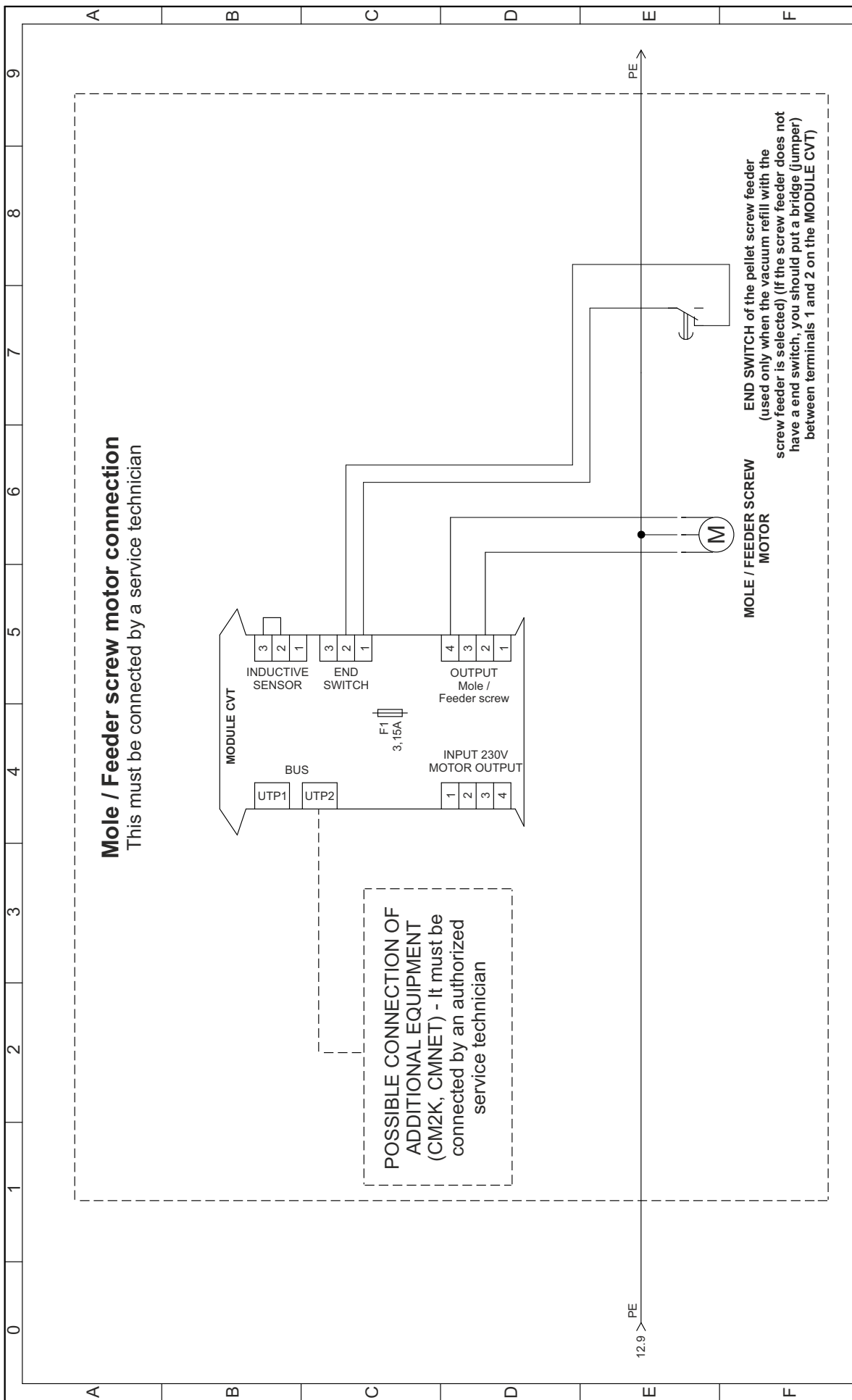

Mole / Feeder screw motor connection
This must be connected by a service technician

POSSIBLE CONNECTION OF
ADDITIONAL EQUIPMENT
(CM2K, CMNET) - It must be
connected by an authorized
service technician

MOLE / FEEDER SCREW MOTOR
END SWITCH of the pellet screw feeder
(used only when the vacuum refill with the screw feeder is selected) (If the screw feeder does not have a end switch, you should put a bridge (Jumper) between terminals 1 and 2 on the MODULE CVT)

Project:
PelTec-Compact 18/24
Date:
10.7.2024.

13/14

PelTec-Compact 18/24

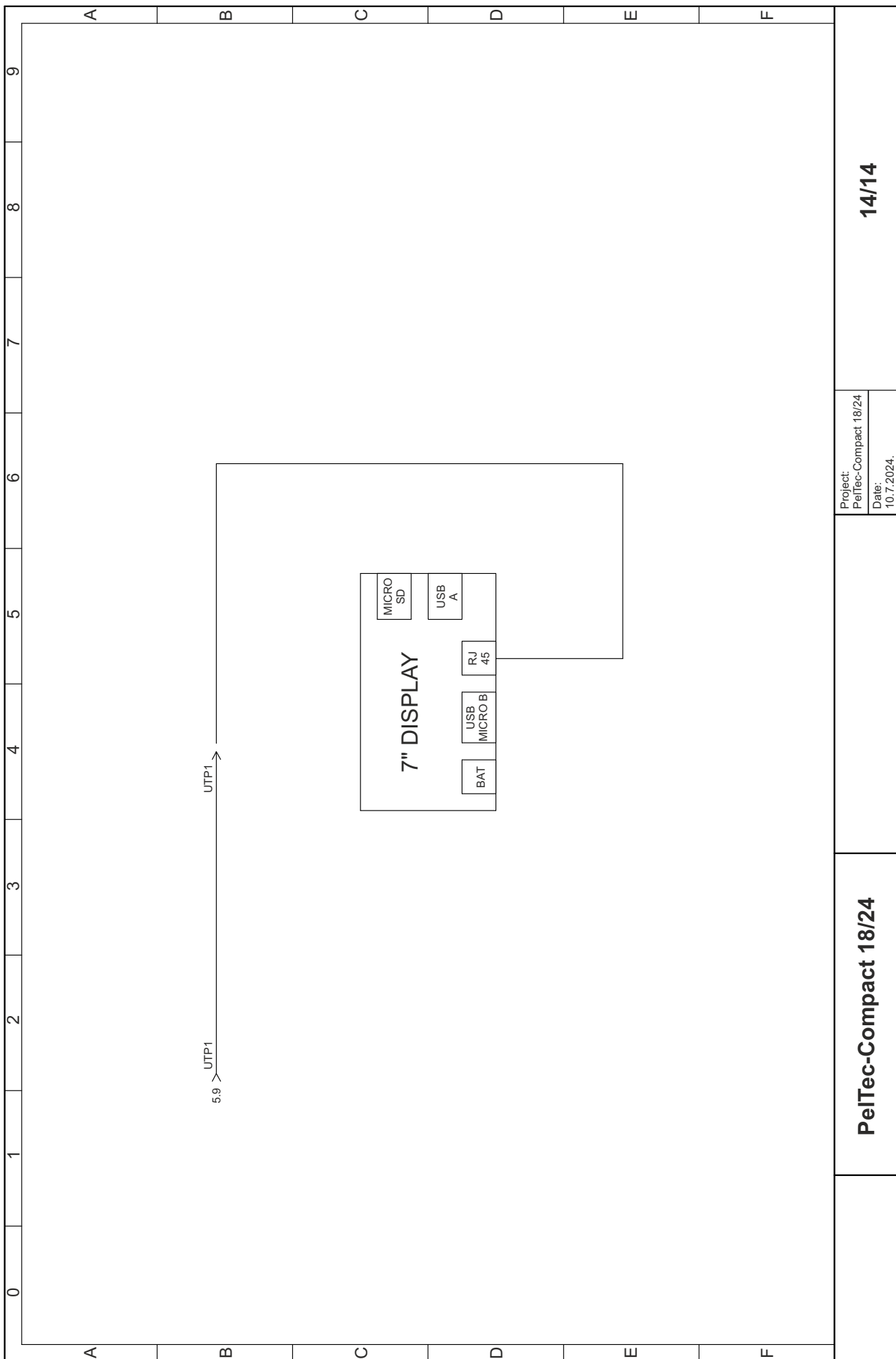

Project:
PeITec-Compact 18/24
Date:
10.7.2024.

14/14

PeITec-Compact 18/24

8.0. OPERATING THE SYSTEM

Boiler must not be used in flammable and explosive environment.

It must not be used by children or disabled persons (either physically or mentally), as well as by person without knowledge or experience, unless they are under control or trained by a person responsible for their safety.

Children must be supervised in the vicinity of the product. If the supply cord is damaged, it must be replaced by the manufacturer, its service agent or similarly qualified.

8.1. SAFETY INSTRUCTIONS FOR THE INSTALLATION ROOM

Boiler room must be frost-proof and well ventilated. Boiler has to be positioned so that it can be properly connected to the chimney (see point 3.0) and simultaneously, enabling tending of boiler and additional equipment, control during operation, and cleaning and maintenance

8.2. INITIAL STARTUP

See technical instructions for PelTec-Compact digital controller where is explained initial startup.

Note:

The start up has to be done by the authorized person, otherwise the warranty for this product is not valid and the product must not be used.

Note:

If condensation escapes during the initial heatup phase, this does not indicate a fault. If this occurs, clean up using a cleaning rag.

8.3. FILLING / REFILLING PELLET TANK WITH FUEL



Use only permitted pellets (see point 1.7. of this technical manual)!

The PelTec-Compact pellet tank is filled automatically via the suction system installed in the boiler.

When the pellet tank is empty, i.e. when the mark on the pellet tank indicates 0% (A), the vacuum supply automatically turns on and fills the pellet tank until the pellets cover the fuel level sensor in the tank (at the top of the side of the tank). When the fuel level sensor is clogged (all green and red LEDs are lit on it), vacuum suction system stops and the mark on the tank starts to show 100% (B). If you don't want to wait until 0% pellets in the tank, the tank can be refilled by pressing the 'x1' button (C) on the KE screen (D). If the boiler is working when the x1 button is pressed, the boiler enters phase F (E), i.e. the boiler shuts down, the pellet tank is filled with pellets, and the boiler automatically turns on again and continues working.

If there are no more pellets in the large tank or vacuum tubes are clogged with pellets and if the vacuum turbine did not manage to cover the fuel level sensor with pellets within the protection time (300 sec + 5x60 sec), the boiler will report an error of empty large pellet tank (E32) and after that an error of no fuel (E22) (F) will appear and the boiler will shut down to the OFF phase.

If the big pellet tank transporter box is filled with pellets, the pellets will press the end switch and the screen will show a image with a red line (G1) and the screw feeder stops working (vacuum turbine continues to work). If the end switch is released (is not pressed anymore) within 30 seconds, a yellow line (G2) will appear and the screw feeder will not run for the next 30 seconds to try to empty the big pellet tank transporter box. If the end switch is not pressed again within the next 30 seconds, the line will be green (G3) and the screw feeder starts working again. If the end switch is not released even after 30 seconds (if it remains pressed) the line will be red, the screw feeder and the vacuum turbine stop working and the error "E52 - Overfilled big pellet tank transporter box" (H) appears.



Filling/refilling

When error E-52 occurs, the vacuum turbine is automatically turned OFF. After cleaning the big pellet tank transporter box, it is necessary to manually turn on the vacuum turbine again (suctiony system).

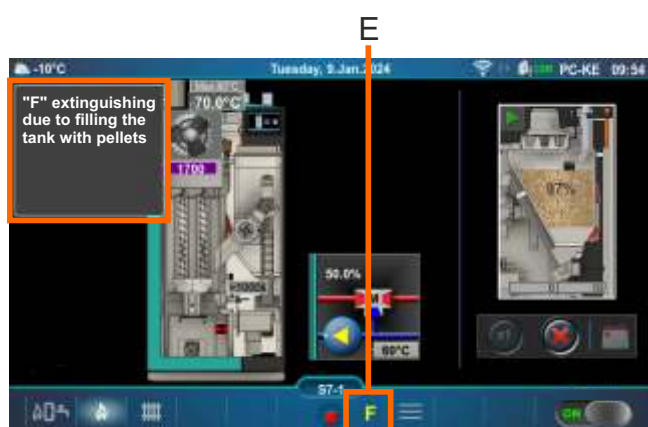
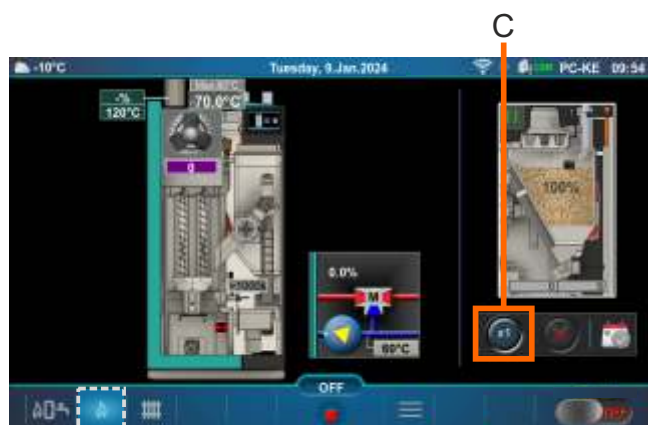
In case of emergency, when the suction system does not work, the tank can also be filled manually. The suction system must be turned off (software - *Operation/Suction system/Suction system: OFF*) (I), remove the lid of the pellet tank with the vacuum turbine (J). The tank must be filled to the top with pellets and the '100%' button (K) must be pressed on the KE screen. By pressing the '100%' button, the number 100% is displayed in the tank. When the tank is 20% empty, the warning 'W1 Fuel level' appears on the screen. This is the time when the tank must be manually filled again. When the tank is emptied to 0%, the error 'E22 Fuel level' appears on the screen and at that moment the boiler goes into the shutdown phase and waits for the tank to be filled with pellets and the '100%' button is pressed.





- G1  Red line: (end switch is pressed - the screw feeder does not work)
- G2  Yellow line: (end switch not pressed - the screw feeder does not work, waits 30 seconds)
- G3  Green line: (end switch is not pressed for more than 30 seconds - the screw feeder is working)

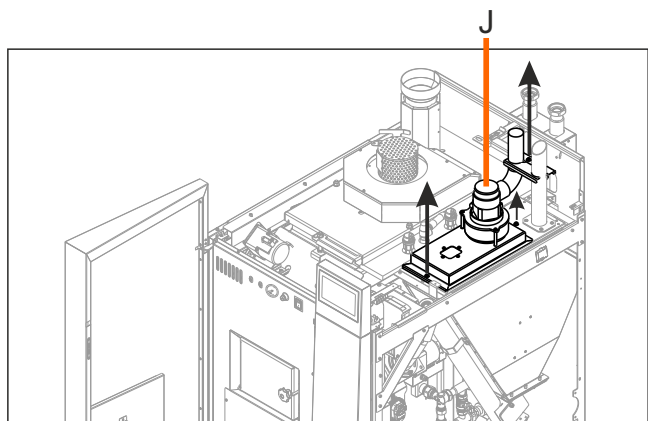
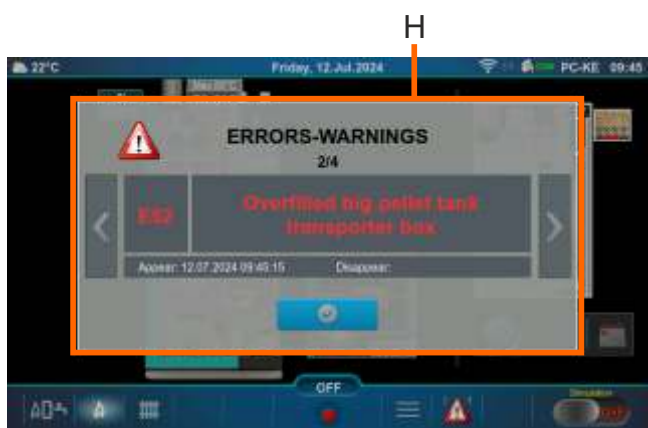

8.4. BOILER USE

Boiler must not be used in flammable and explosive environment.

It must not be used by children or disabled persons (either physically or mentally), as well as by person without knowledge or experience, unless they are under control or trained by a person responsible for their safety. Children must be supervised in the vicinity of the product. If the supply cord is damaged, it must be replaced by the manufacturer, its service agent or similarly qualified persons in order to avoid a hazard. Protective gloves are obligatory.

Check whether boiler and equipment are installed and connected in accordance with these Technical instructions. Check whether chimney meets requirements of point 3.0 therein. Check whether boiler room meets all requirements therein. Check if fuel fulfils all requirements therein. Check whether the boiler and the entire heating system are filled with water and vented.

Note:

Before every use check if the boiler doors and cover door are closed (Figure 12).

If you smell flue gas:

- Shut down the heating system
- Ventilate the boiler room
- Close all doors leading to the living space



Flue gas can lead to life-threatening poisoning!

Figure 12. PelTec-Compact boiler doors

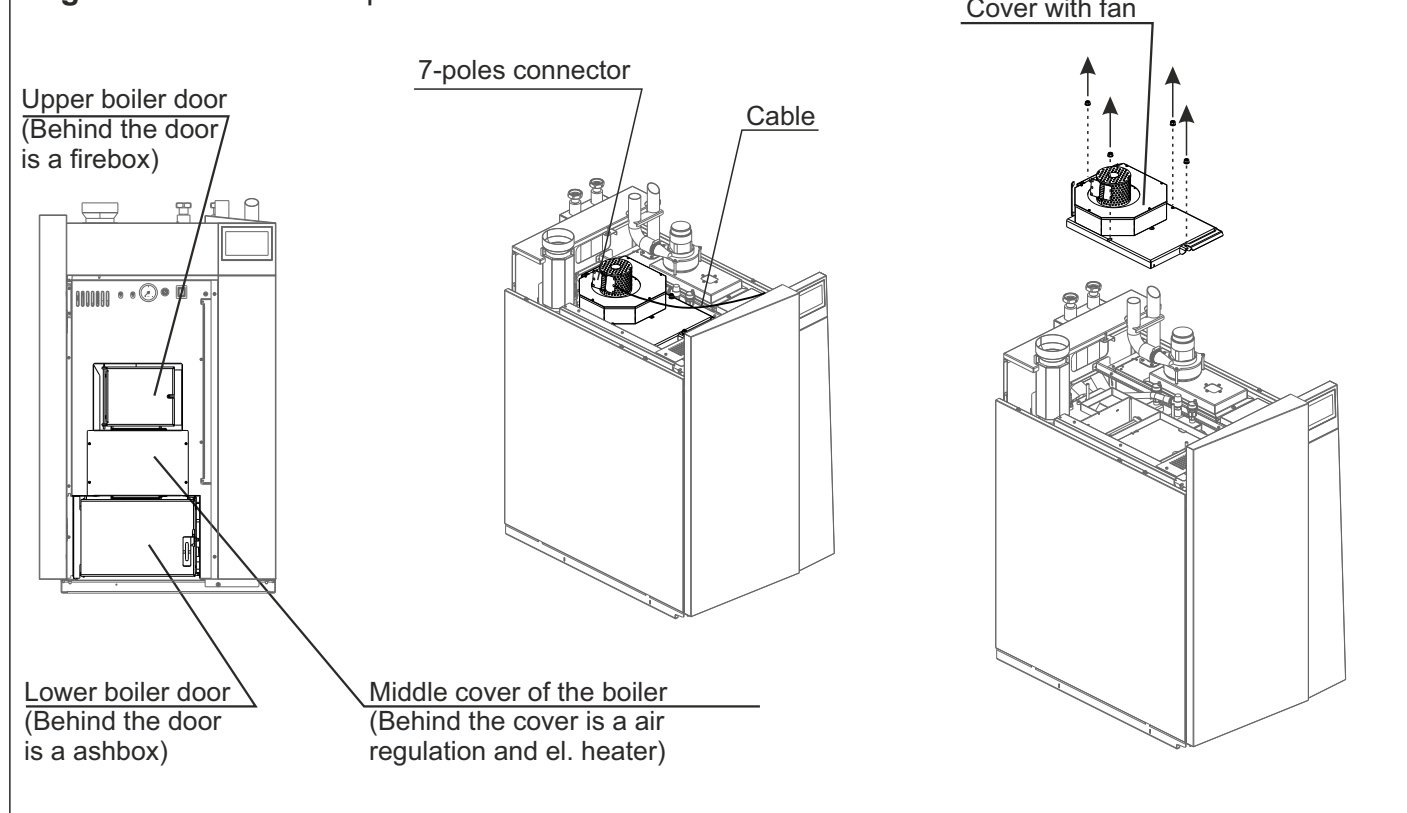

Important!

You must use this boiler in accordance with these technical instructions, the technical instructions of the PelTec-Compact control unit and the technical instructions that came with the additional equipments.

9.0. CLEANING AND MAINTENANCE

Every millimeter of soot on the exchange surfaces and in the flues means about 5 % more fuel consumption. A clean boiler saves fuel and protects the environment.

Save fuel – always clean the boiler in good time!

PROTECTIVE GLOVES ARE OBLIGATORY!



ACCORDING TO NEED, THE RIGHT SIDE OF THE COVER CAN BE REMOVED.

1. Take the cover on the right side of the boiler (1A) by the handles (1B) and pull it out (1C).

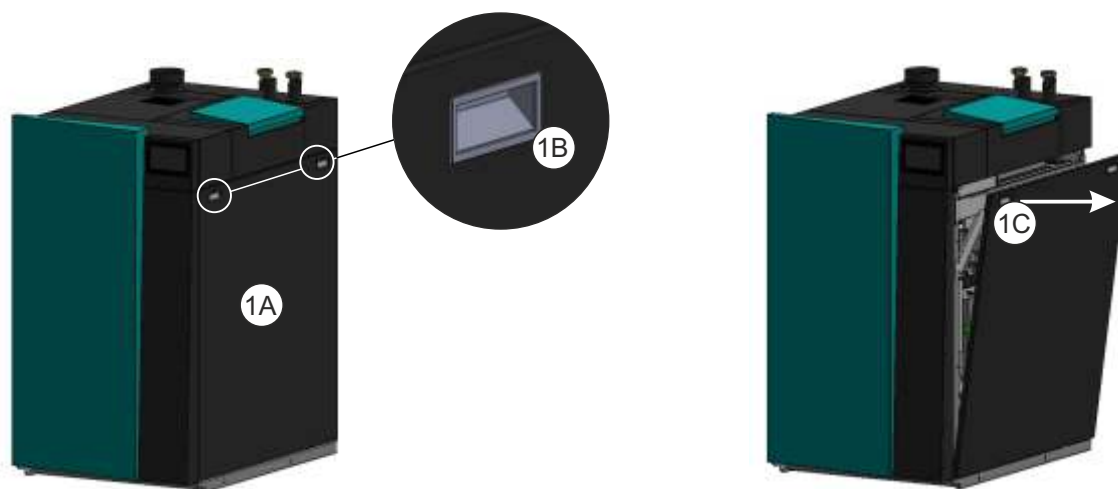

2. Lift the cover slightly upwards (2A), to separate it from the hooks (2B) and pull it to you. Once the cover has been lifted and separated, it can be removed (2C).

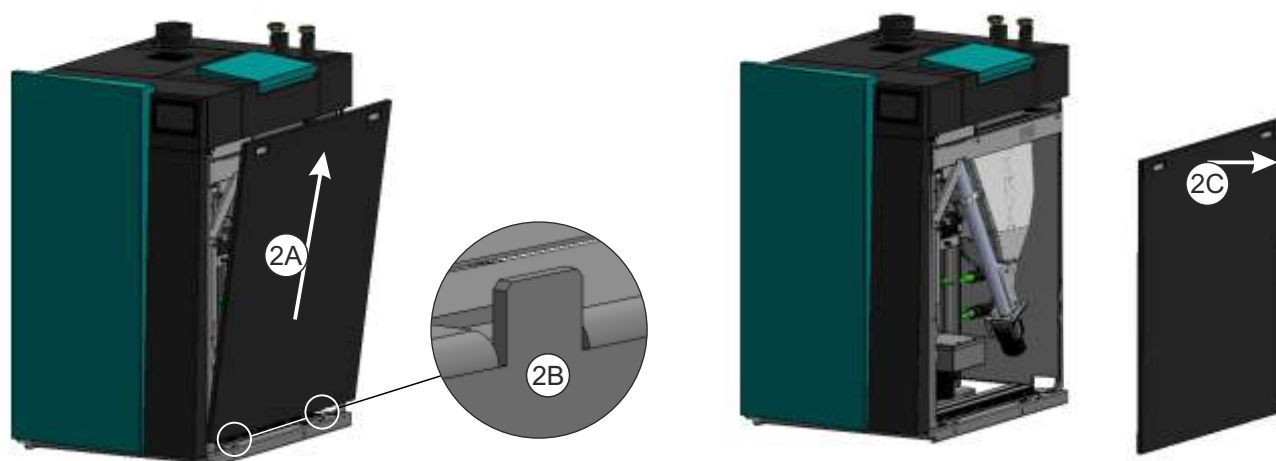

9.1. CLEANING AND MAINTENANCE - PERIODICALLY

9.1.1. EMPTYING THE ASH BOX

Cleaning interval	Boiler type	Description
After spent 150-500 kg of pellets	12kW	Discharge ash boxes
After spent 250-750 kg of pellets	18kW	Discharge ash boxes
After spent 250-750 kg of pellets	24kW	Discharge ash boxes

Emptying the ash box:

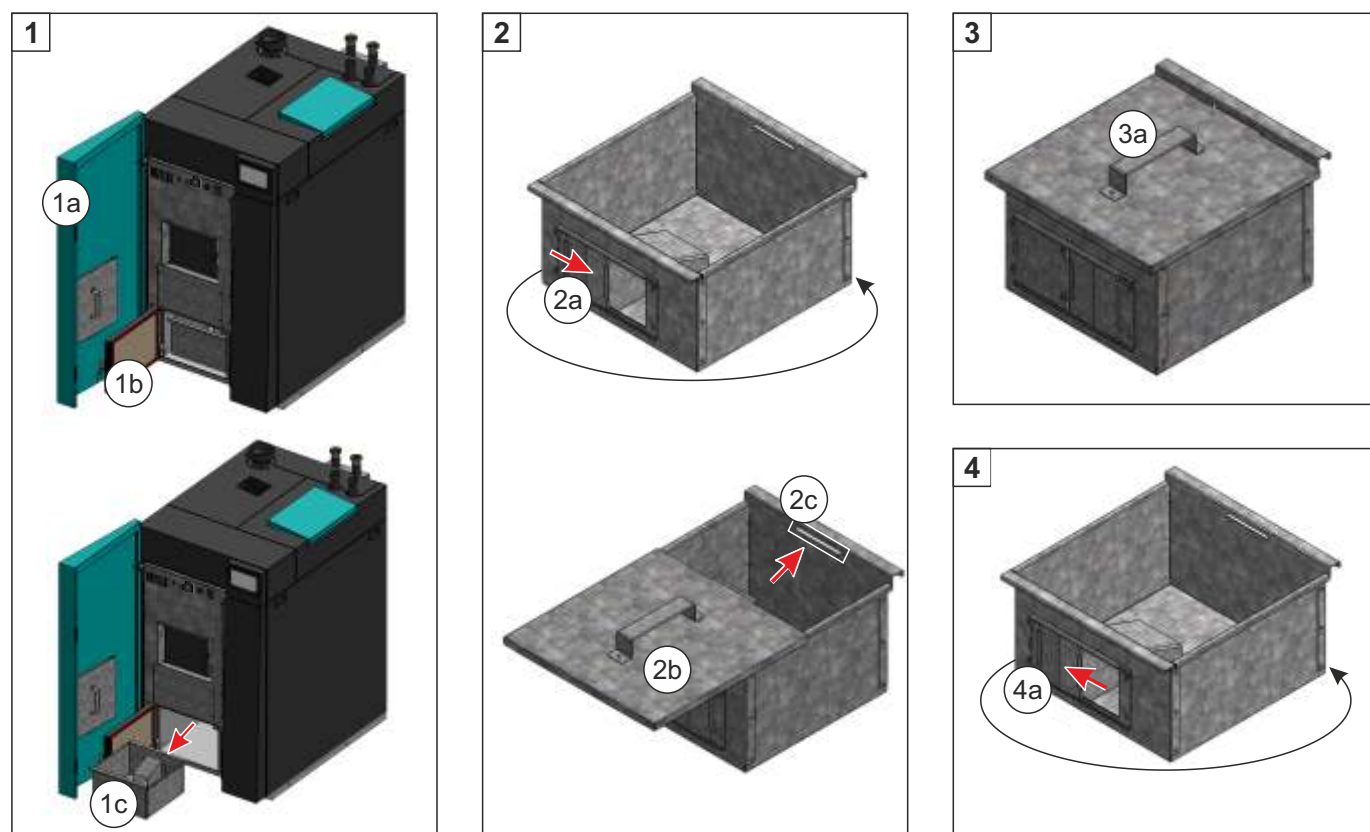

1. Open the front left boiler cover door (a1) and the lower boiler door (1b) and take out ash box (1c).
2. Turn the box over and close the small door (2a). Place the lid of the box (2b) in the hole (2c) so that it can be carried.
3. The closed box can be carried using the handle (3a).
4. After the ash box has been emptied, remove the lid, open the small door (4a) and return the ash box to its original position in the boiler.

IMPORTANT! The ash can be disposed only in a metal container!

9.1.2. CLANING OF EXCHANGING SURFACES (ABOVE THE BURNER)

Cleaning interval	Boiler type	Description
At least once per year (This procedure is very simple and is recommends even more often)	12-24 kW	Cleaning of exchanging surfaces (above the burner)

Clanling of exchanging surfaces (above the burner)

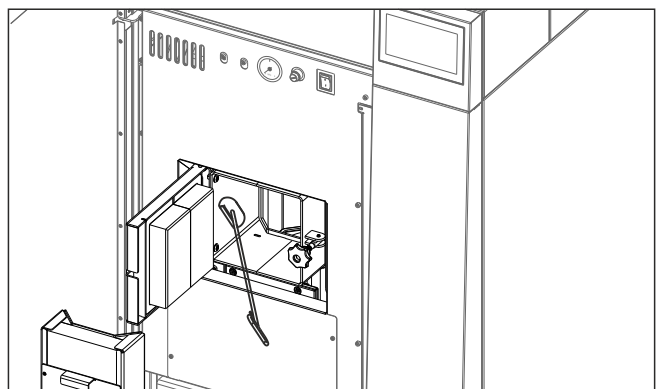
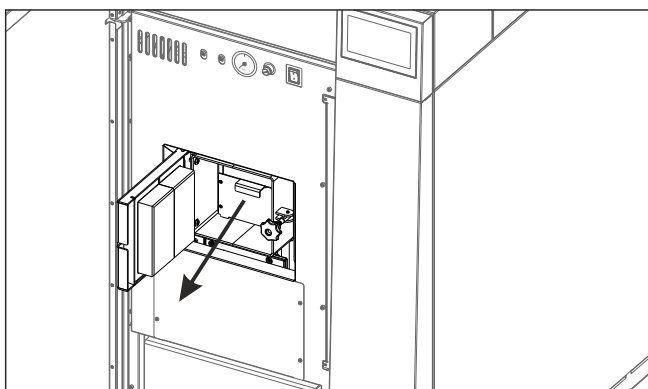
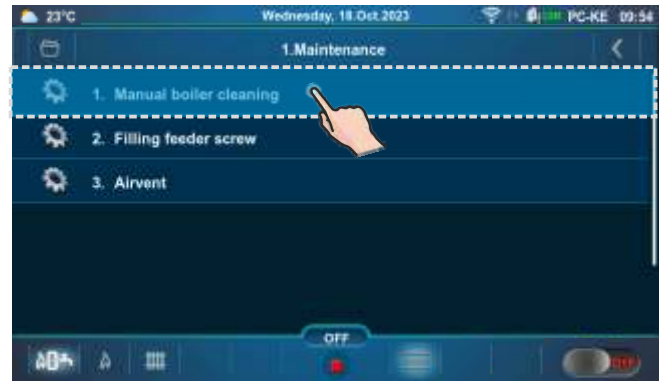
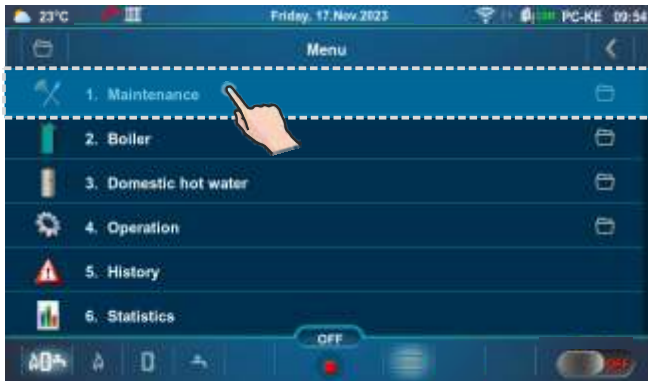

- 1 - Press the "Maintenance" on the controller and then "Manual boiler cleaning".
- 2 - Press the "ON" button with the desired fan speed.
- 3 - The fan turns on and the grate cleaning mechanism opens - (in the example 800 rpm).
- 4 - Take out "Insert - upper door opening"
- 5 - By using scraper, brush or vacuum cleaner, through the door clean exchanging surfaces.
- 6 - After you finish cleaning, put the "Insert - upper door opening" back in its place, press "Back" () on controller to control the boiler back to normal mode and close the upper boiler door.

9.1.3. CLEANING THE BLADES AND BOX OF THE FAN

Cleaning interval	Boiler type	Description
When needed	12-24 kW	Cleaning the blades and box of the fan

Cleaning the blades and box of the fan

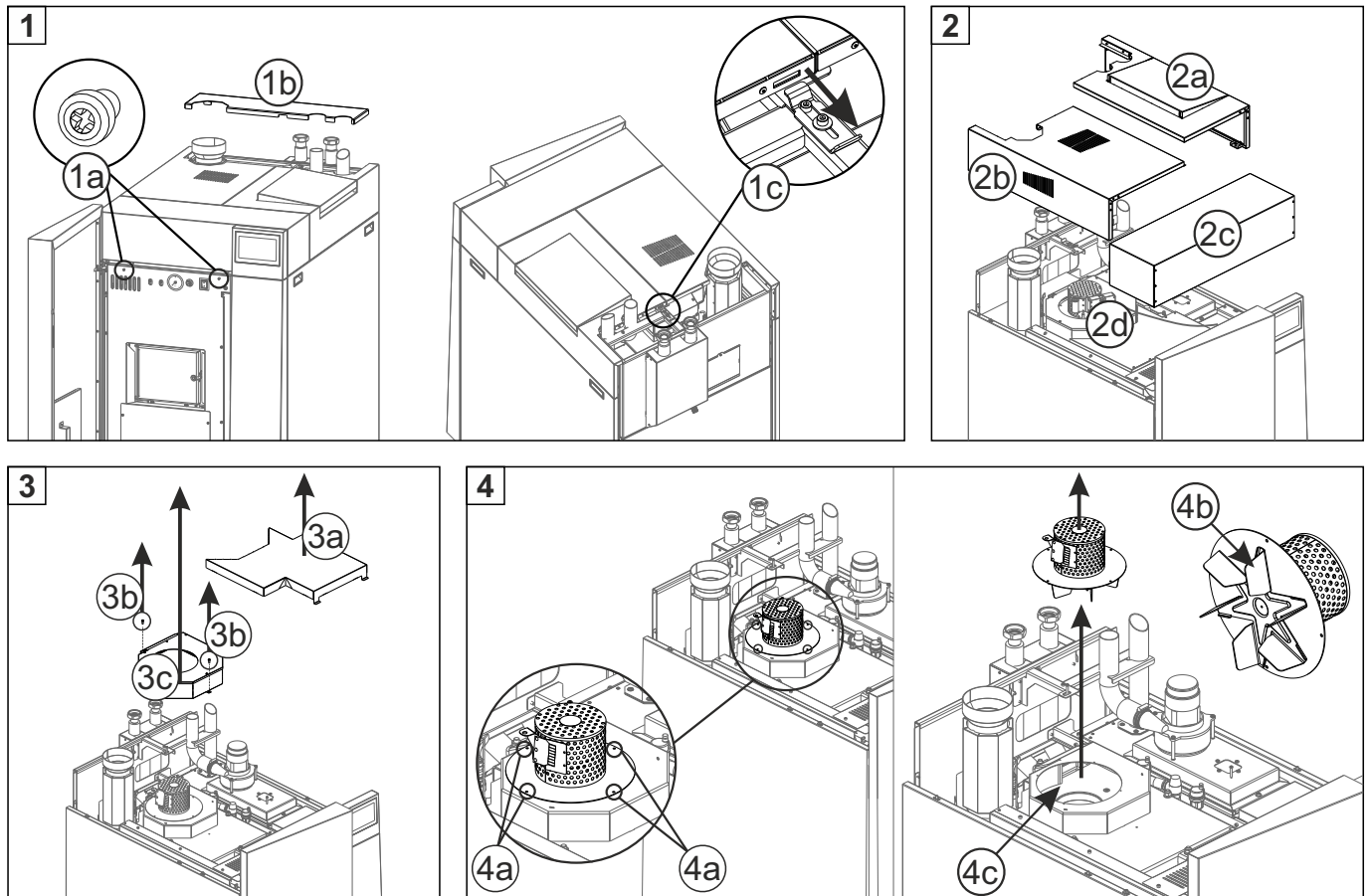

Switch the boiler OFF and disconnect it from electric power.

- 1 - Open the front boiler cover and unscrew the 2 screws (1a). Remove the upper rear cover (1b). On the back of the boiler, unscrew the screw that holds the hook and pull the hook out (1c).
- 2 - Remove the upper lids from the boiler cover (first 2a, then 2b, and finally 2c). Disconnect the cable from the connector (2d).
- 3 - Remove the thermic insulation of the upper boiler cover (3a) and unscrew the 2 screws (3b) and remove the cover of the fan box (3c).
- 4 - Unscrew the 4 screws (4a) and separate the fan, clean the fan blades (4b), check the condition of the fan box (4c) and clean it when is necessary by using vacuum cleaner.

NOTE:

Place all the parts back in the same way but in the reverse order!

PROTECTIVE GLOVES ARE OBLIGATORY!



9.1.4. CLEANING OF EXCHANGING SURFACES (AROUND THE ENTIRE BOILER)

Cleaning interval	Boiler type	Description
At least once per year	12-24 kW	Cleaning of exchanging surfaces (around the entire boiler)

Switch the boiler OFF and disconnect it from electric power.

- 1 - Open the front boiler cover and unscrew the 2 screws (1a). Remove the upper rear cover (1b).
- 2 - On the back of the boiler, unscrew the screw that holds the hook and pull the hook out (2a).
- 3 - Remove the upper lids from the boiler cover (first 3a, then 3b, and finally 3c). Disconnect the cable from the connector (3d).
- 4 - Remove the upper thermal insulation cover (4a). Unscrew the 4 nuts and washers (4b) from the fan casing.
- 5 - Grab the handles (5a) to lifting/removing the fan casing cover. Using the handles (5b), remove the flame protection (5c).

By using scraper, brush and vacuum cleaner, clean exchanging surfaces. When you have finished cleaning, set upper cover back to original position and tighten them well.

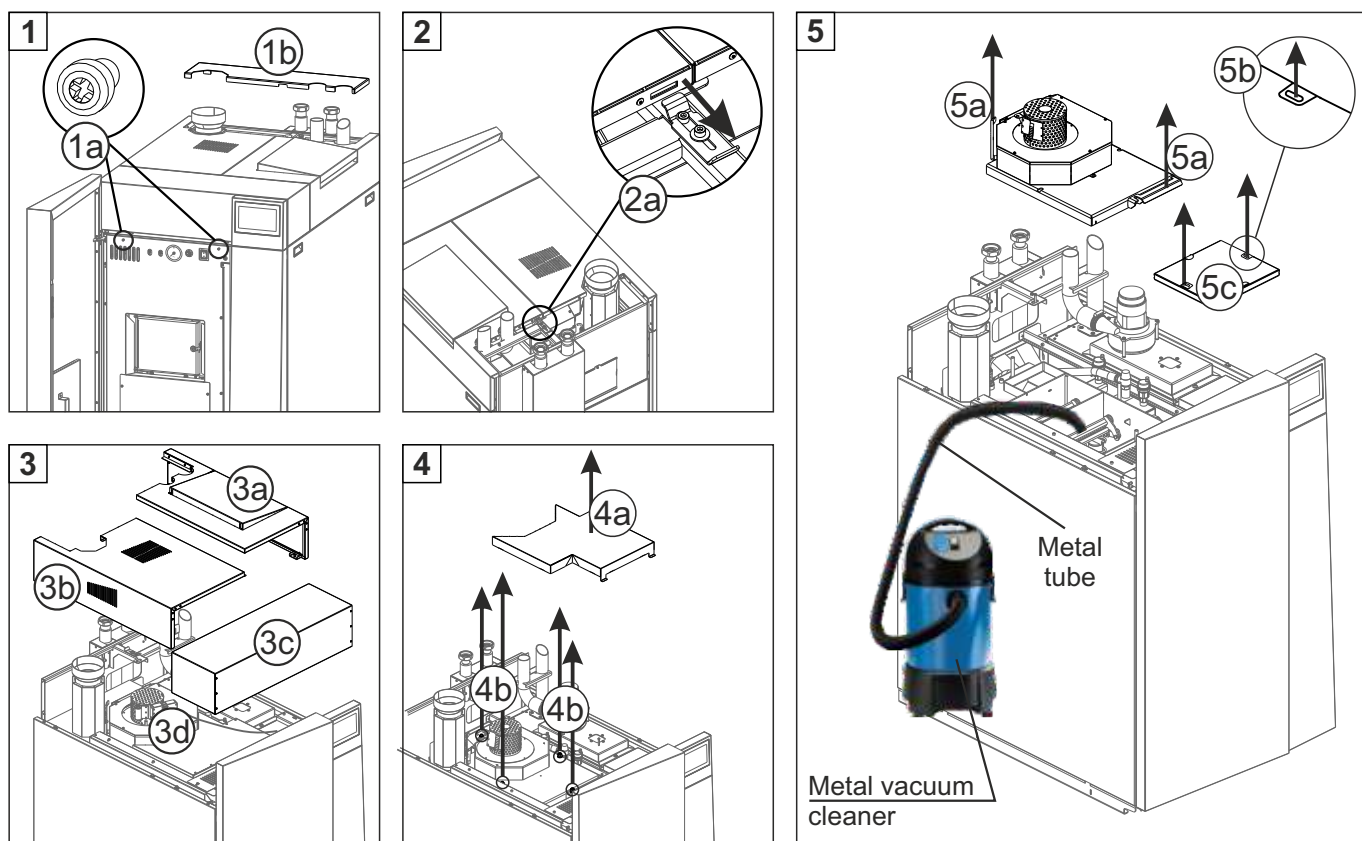

9.1.5. CHECKING THE CORRECTNESS OF SAFETY VALVE

Cleaning interval	Boiler type	Description
Every 6 months	12-24 kW	Check the correctness of safety valve



Checking the correctness of safety valve



By briefly turning the cap of safety valve check whether water coming out from the safety valve. If no water comes out after several repeated checks, then is necessary to replace the safety valve.



9.1.6. PHOTOCCELL CLEANING

Cleaning interval	Boiler type	Description
At least once a year (or if you have problems with the ignition)	12-24 kW	Photocell cleaning
		
<p>Dirty photocell which can result error in ignition or flame dissapear error</p>		<p>Valid photocell</p>

Carefully remove the photocell from the box and then gently with a cotton swab clean the body and lens of photocell. After cleaning, carefully return photocell to work position.

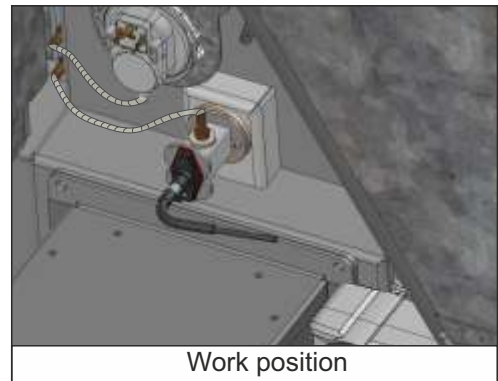

Work position

Return the covers back in the same way but in the reverse order.

Cleaning interval	Boiler type	Description
At least once per year	12-24 kW	Cleaning and checking the flue installation sealing

Cleaning and checking the flue installation sealing

Clean flue installation between the boiler and the chimney through the revision openings for cleaning or if not incorporated revision opened by removing the flue installation. After cleaning, inspect flue installation good sealing and seal it if the seal is not satisfactory.



The ecological rules and standards must be applied for disposal of changed spare parts, wrapping material, all parts of the boiler after it's expire.

1. Electric heater
2. Failure on distribution power box with digital boiler control unit
3. Fan failure
4. Pellet feeder Motor failure
5. Temperature sensors failure
6. Photocell failure

Every seven years to call an authorized service provider for routine maintenance and control!

9.2. CLEANING AND MAINTENANCE - IF NEEDED

9.2.1. EXTRACTION OF TURBULATORS

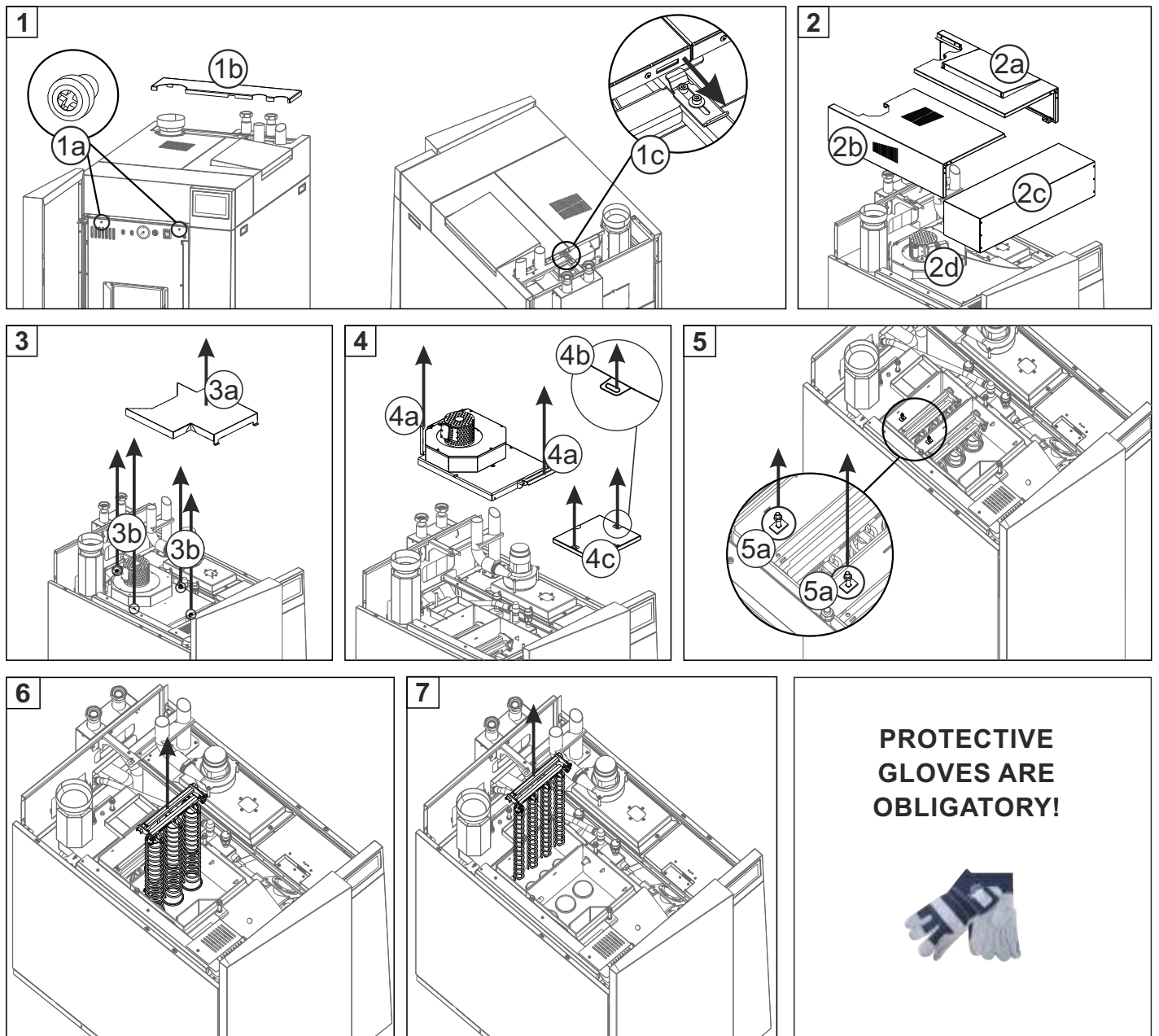

Switch the boiler OFF and disconnect it from electric power.

1 - Open the front boiler cover and unscrew the 2 screws (1a). Remove the upper rear cover (1b).

On the back of the boiler, unscrew the screw that holds the hook and pull the hook out (1c).

2 - Remove the upper lids from the boiler cover (first 2a, then 2b, and finally 2c). Disconnect the cable from the connector (2d).

3 - Remove the upper thermal insulation cover (3a). Unscrew the 4 nuts and washers (3b) from the fan casing.

4 - Grab the handles (4a) to lifting/removing the fan casing cover. Using the handles (4b), remove the flame protection (4c).

5 - Unscrew the 2 screws (5a).

6 - Lift turbulators of first pass with bracket as shown in picture.

7 - Lift turbulators of second pass with bracket as shown in picture.

NOTE:

Place turbulators back in the same way but in the reverse order!

9.2.2. REPLACEMENT OF THE ELECTRIC HEATER



Electric heater with a diameter of \varnothing 20 mm

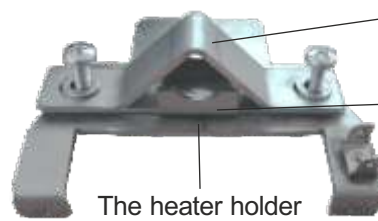

The heater holder with clamp for electric heater with a diameter of \varnothing 20 mm

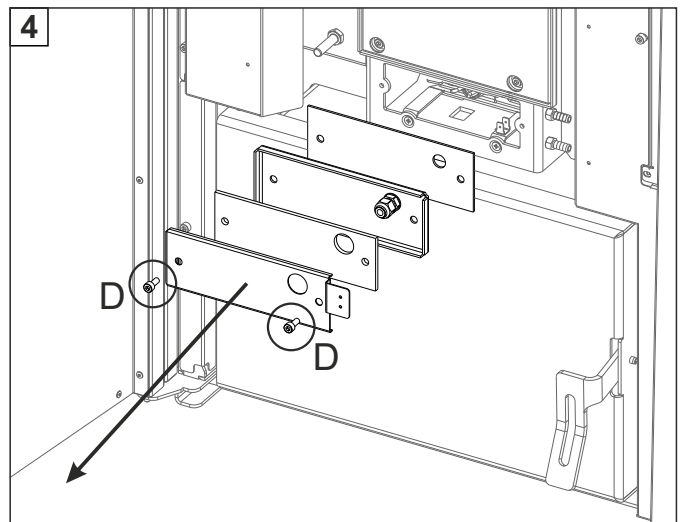
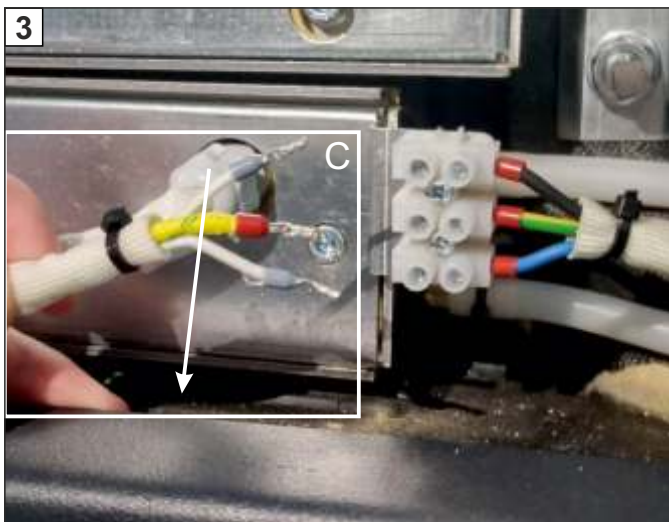
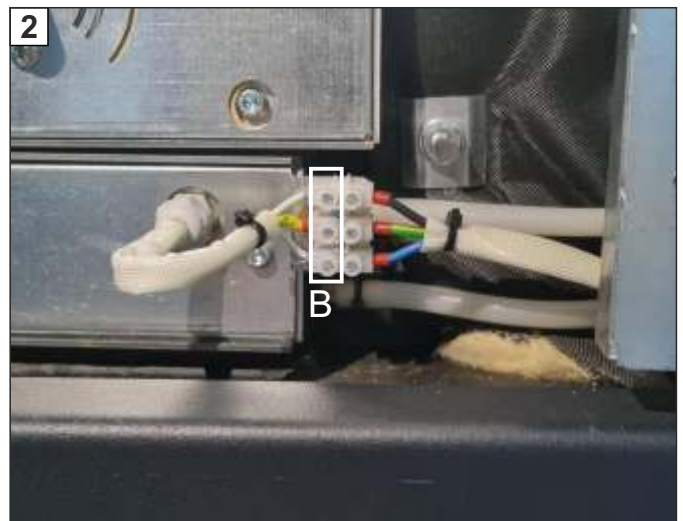
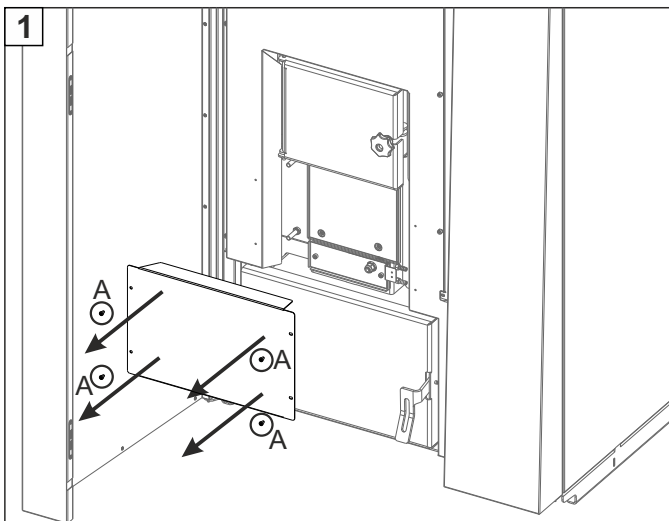

1. Open the door and remove the middle cover (unscrew A x4).
- 2.,3. Disconnect the wires of the electric heater from the terminal block (B) and remove it (C).
4. Unscrew the 2 screws (D) which holding the 4 covers, remove the 4 covers.

Replacement of the electric heater

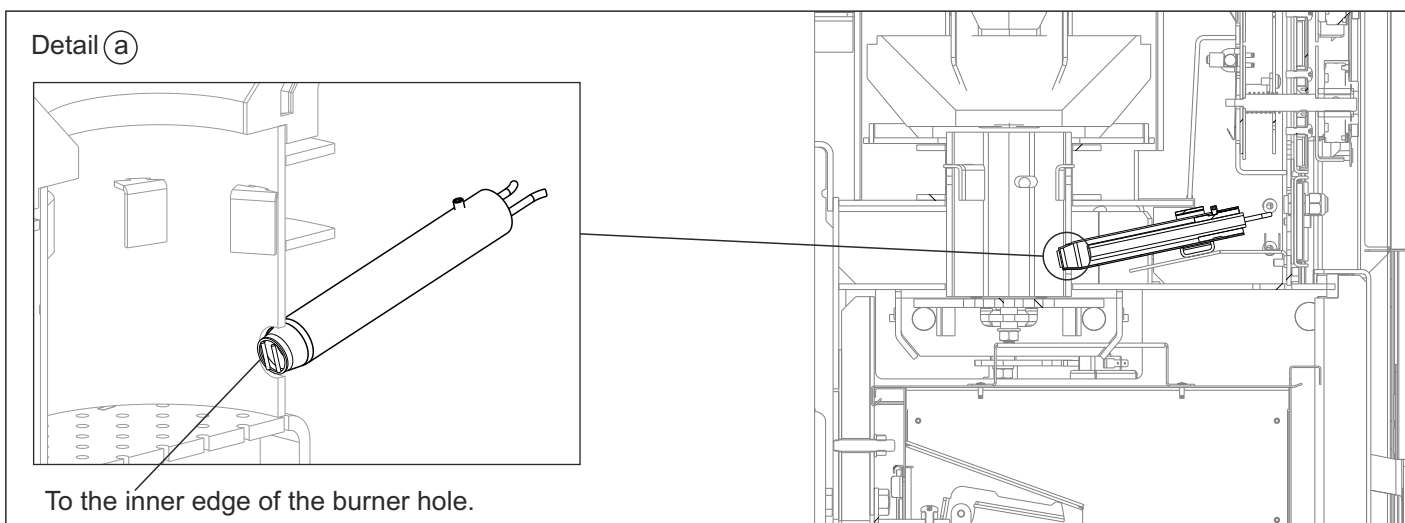
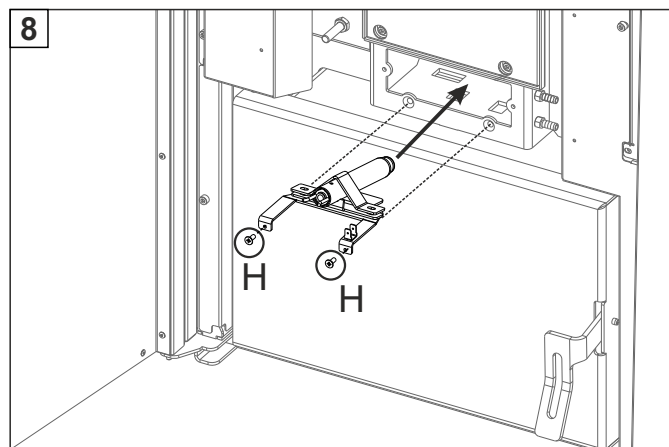
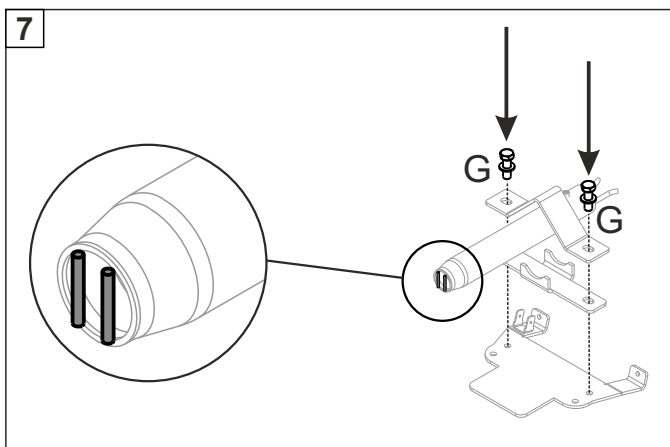
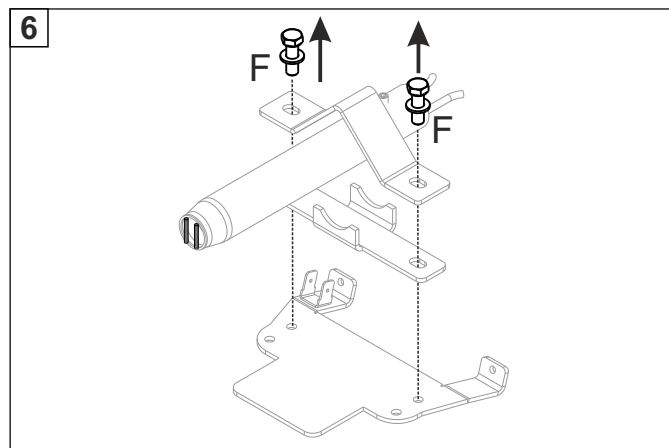
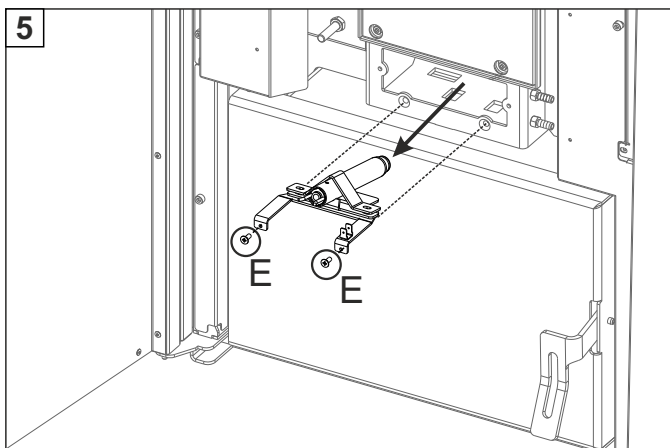

To the inner edge of the burner hole.

5. Unscrew the 2 heater holder screws (E) and pull out heaters holder together with the el. heater.
6. Unscrew the 2 screws (F) and remove the heater clamp.
7. Insert the new el. heater, turn it so that the shaft at the front part of the el heater is turned vertically and gently attach it to the heater holder with 2 screws (G) (still not fully tightened and shafts at the front part of the el. heater are placed vertically).
8. Place the el. heater with the holder in place and fasten it with two screws (H). The heater set to the inner edge of the burner hole (detail a). If necessary, loosen the clamp of the heater holder and push the holder until the edge of the burner hole and then tighten the clamp.

NOTE:

Place all others parts back in the same way but in the reverse order!

9.2.3. CLEANING THE FLUE BOX

1. Unscrew the cover lid (a) of the boiler body on the back side.
 2. Move the wool insulation and unscrew the cover of the flue box using two screws (b) and remove the washers (b). Remove the flue box cover (c) together with the rubber seal (d).
 3. Clean the flue box with an ash vacuum cleaner (e).
- After cleaning, put all parts back in place in reverse order.

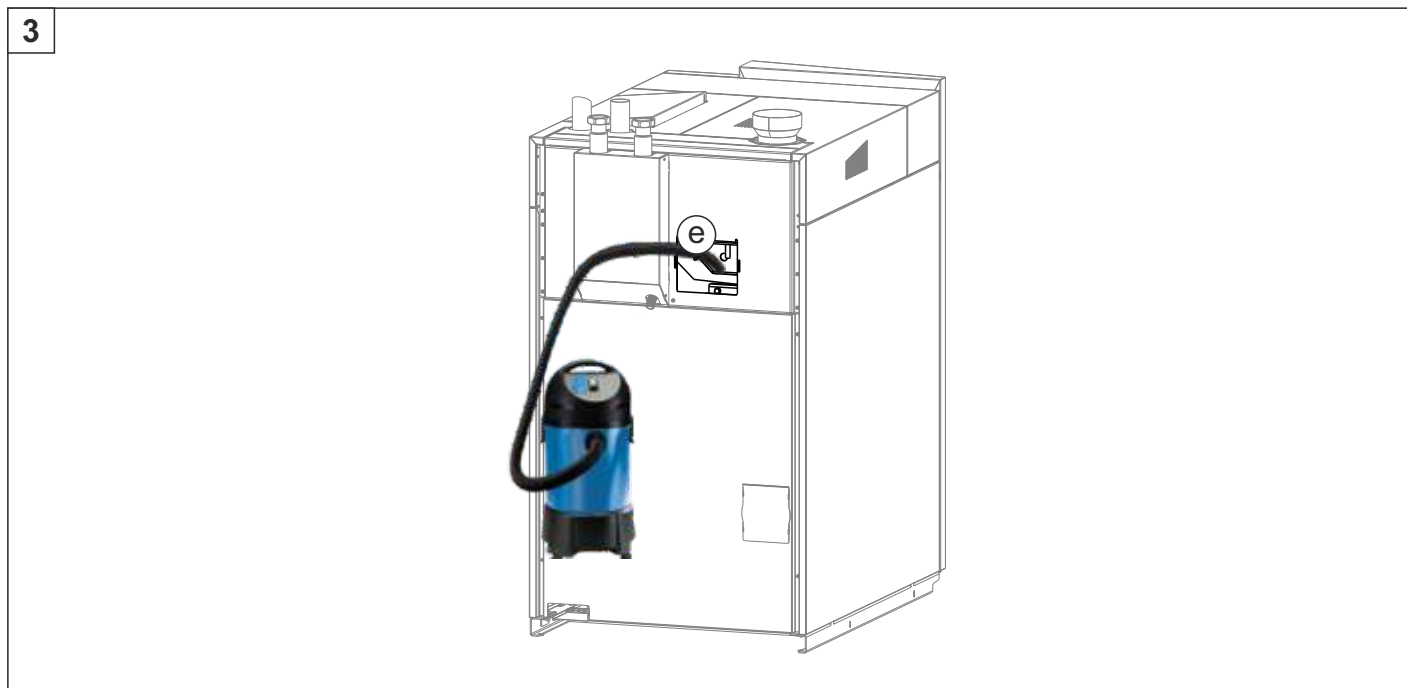
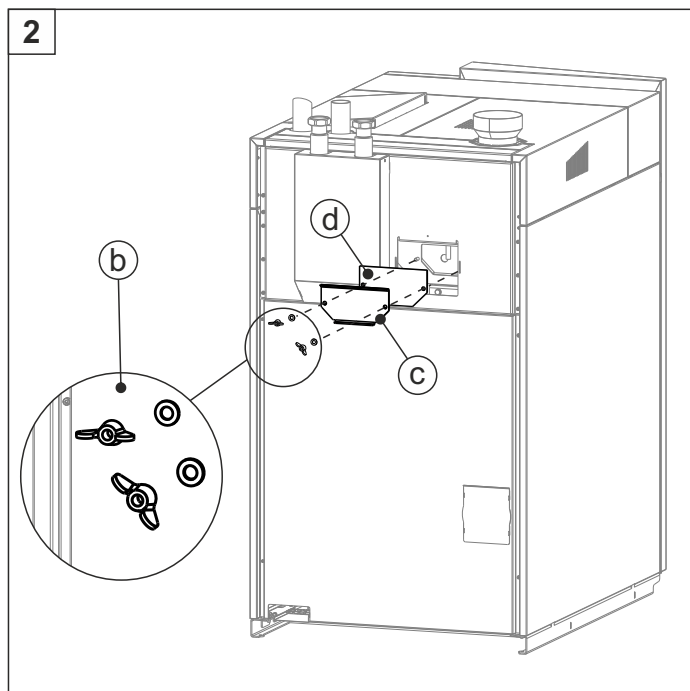
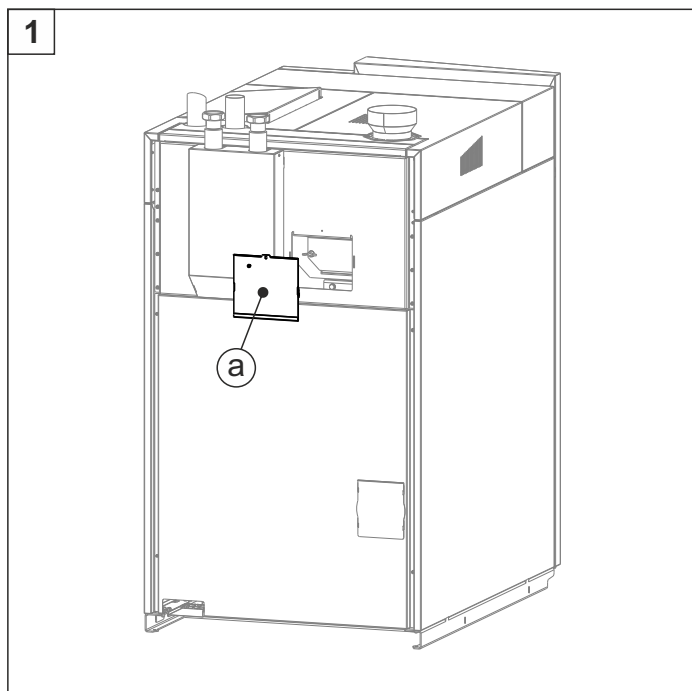

9.2.4. CLEANING OF PELLET TANK

Empty the pellet tank as you can with feeder screw with Manual test.

Note: Switch off the boiler and disconnect it from electric power.



1. Open right cover.



2. Unscrew 2 screws and open side cleaning lid of the pellet tank.



3. With vacuum cleaner vacuum all the dust and residues from pellet tank.



4. Close back cleaning lid of the pellet tank airtight with screws.

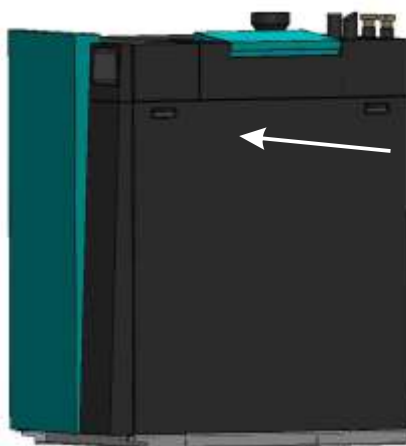

5. Put back right casing lid and start the boiler back on.

9.2.5. DRAINING WATER FROM THE BOILER

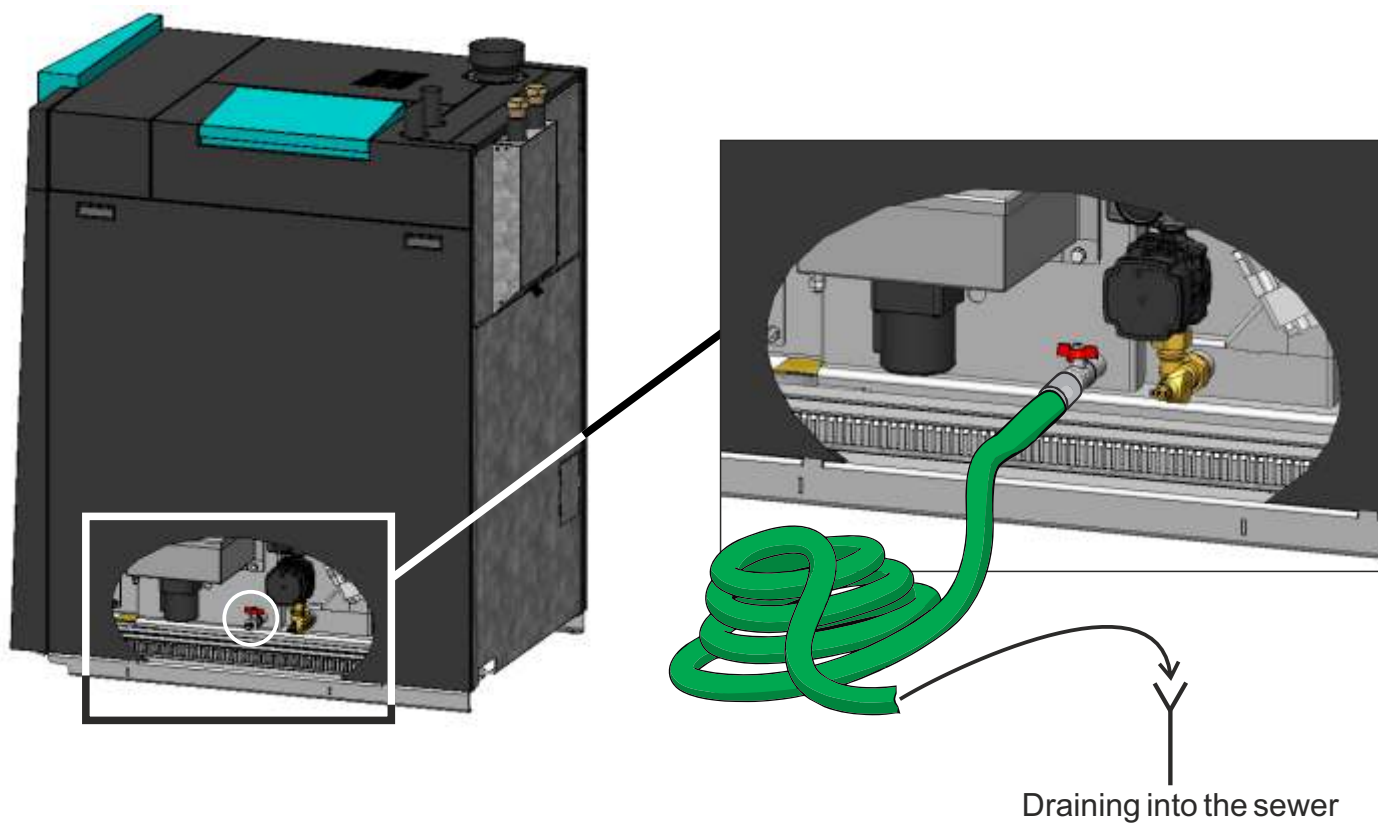

9.2.6. DISASSEMBLY / RETURN TO ITS PLACE ASH EXTRACTION SCREW

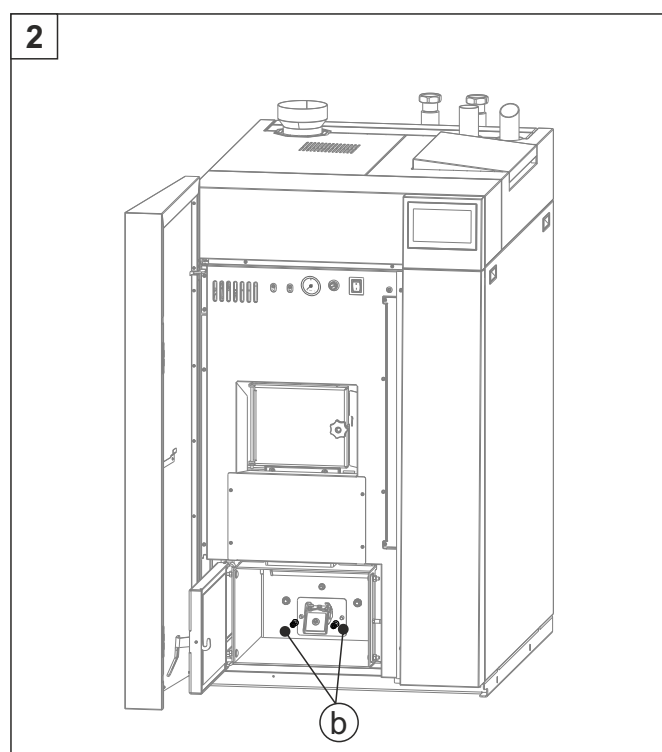
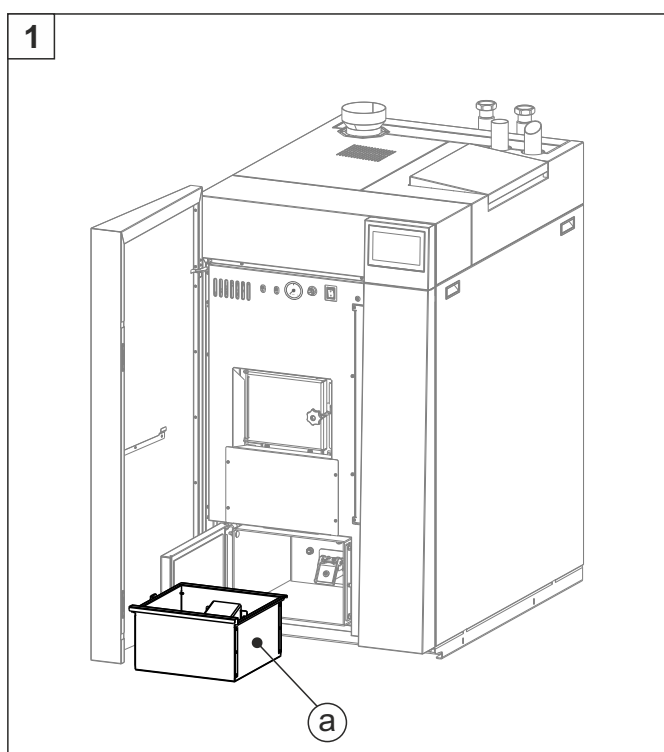

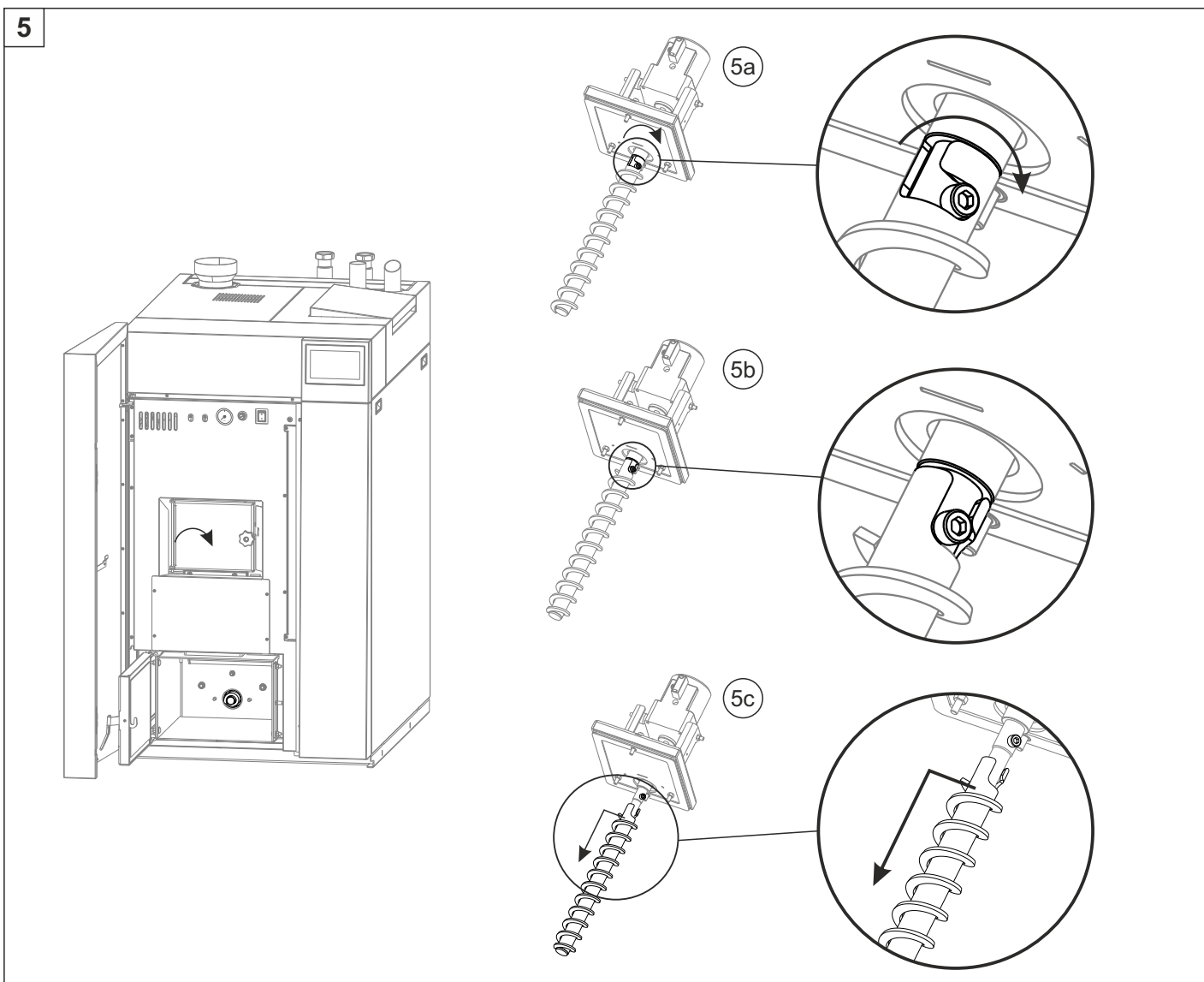
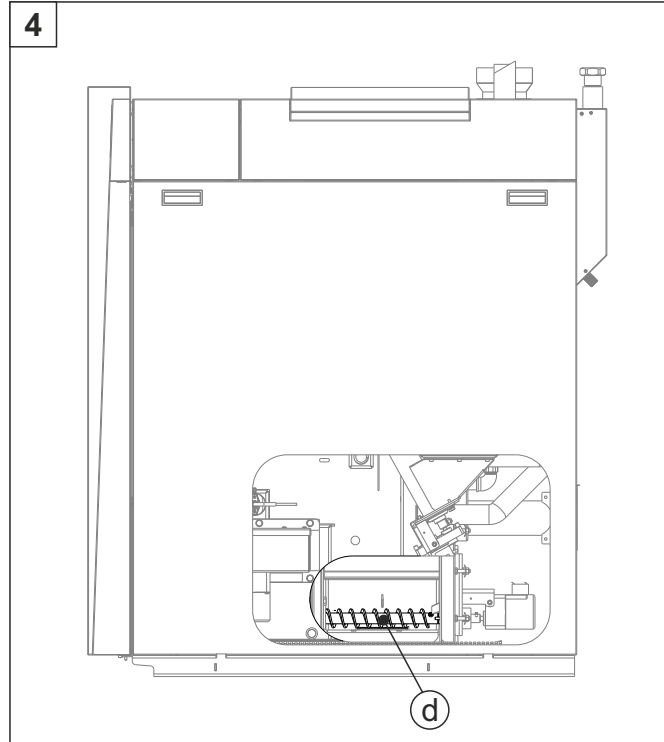
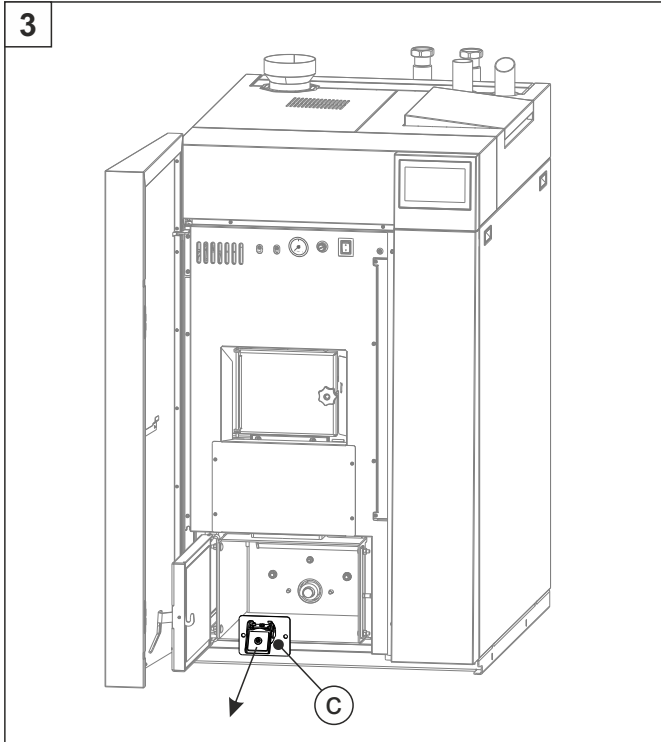

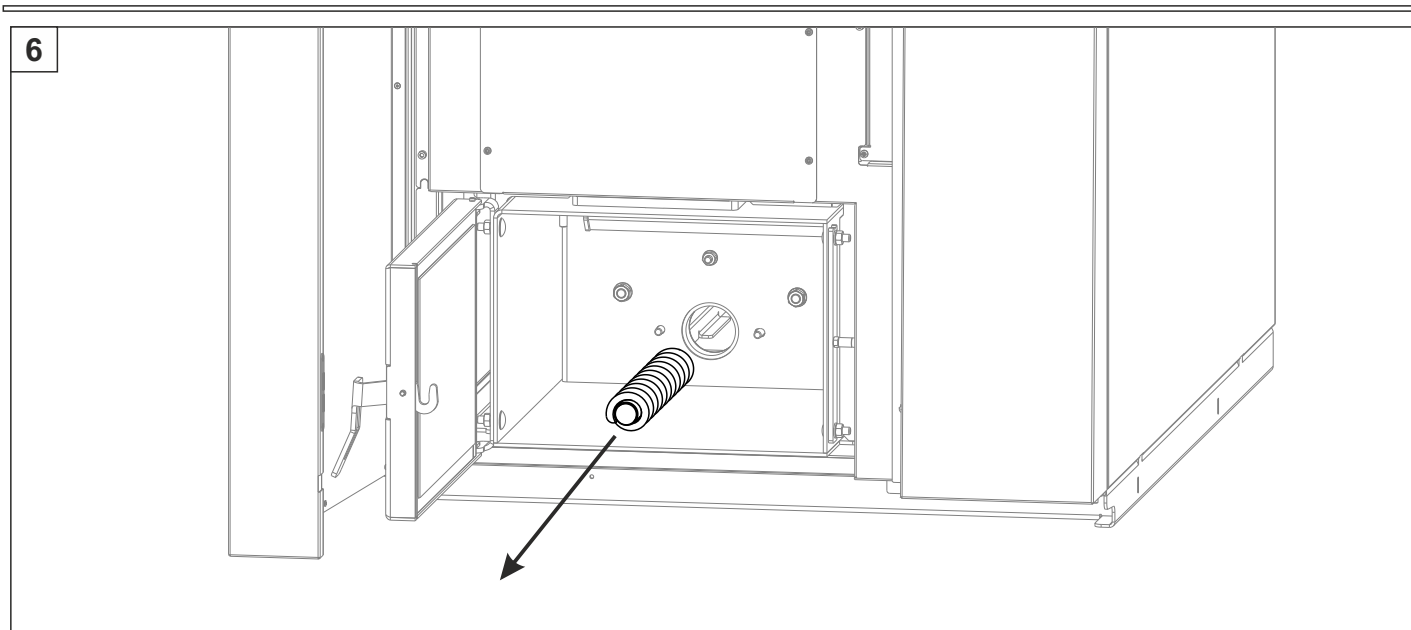

1. Remove the ash box (a) located behind the bottom door of the boiler.
2. Unscrew two nuts together with washers (b).
3. Remove the ash box flap (c).
4. Position of the screw feeder in the boiler (d).
5. Turn the screw feeder to the right - see the arrow in figure 5a (in figures 5a and 5b there are details showing the condition of the screw feeder before and after turning to the right). When the screw feeder reaches the state as shown in the detail of figure 5b, pull the screw feeder out of the boiler (figure 5c).
6. View of the screw feeder removed from the boiler.
7. Return the screw feeder to its original position in the reverse order.

9.2.7. CHANGING THE BOILER CONTROL UNIT SCREEN BATTERY (CR 1632)

If there is a significant clock delay or the clock settings are automatically set to 00:00 and the date to 1.1.2020. (after turning OFF/ON the main switch of the boiler or after a power failure) it is necessary to replace the battery located on the bottom side of the screen (battery type CR 1632). The battery needs to be replaced even if the warning W 9 or error E 48 appears. The clock can be wrong, the delay can be 2-3 minutes per month which is considered normal, we recommend that you adjust it periodically. How to adjust the clock is described in the technical instructions for controller_book_2/2.

The battery is located on the bottom side of the screen (1). First, use a small thing to pull out the plastic box battery (2), which has two polarities (3). Replace the battery and make sure it is turned the right way (4). Place the battery in the plastic box (5) and insert it to the end of the slot so that it is in its original position, aligned with the metal part (6).



9.2.8. MIXING VALVE (3-way mixing valve with actuator - boiler circuit) - POSITION OPEN / CLOSED

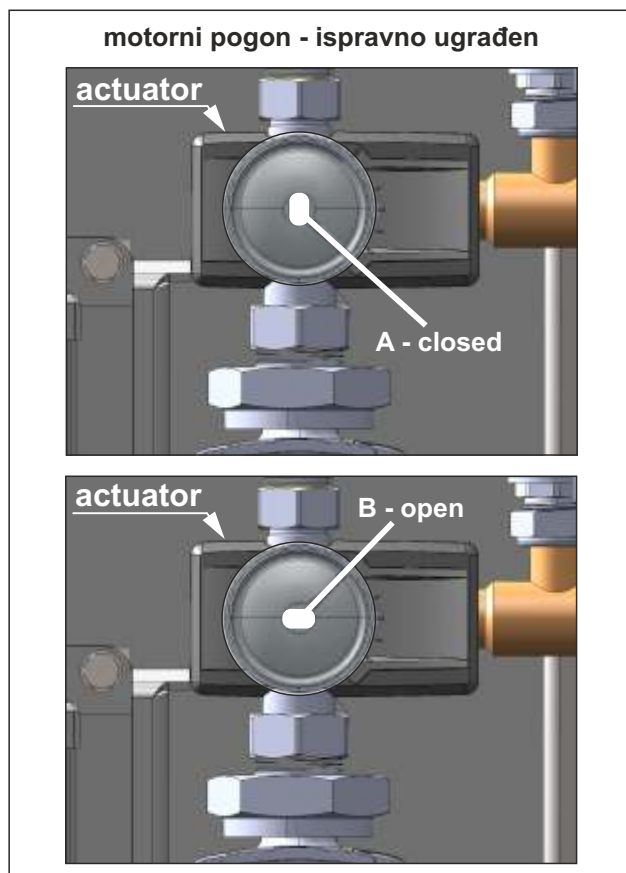
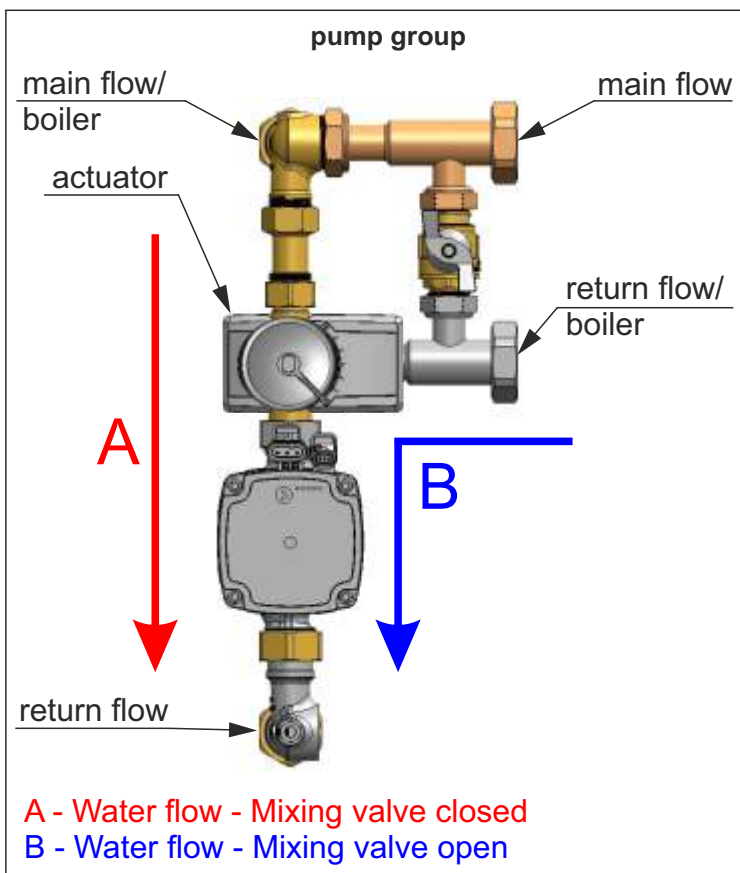

1. Removing the actuator

Pull the plastic part (X) on the back of the actuator in the direction to unlock and pull the actuator out (toward himself).

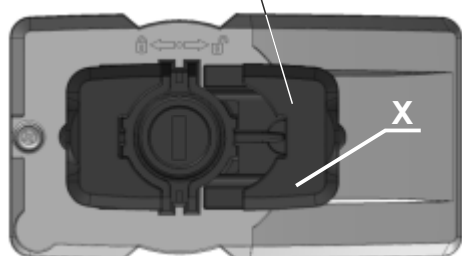
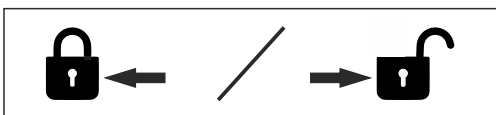
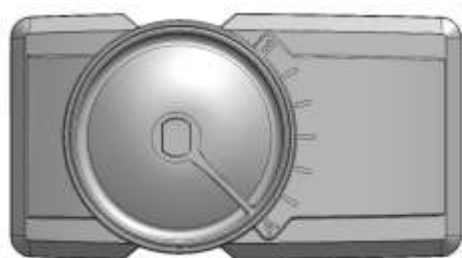

pump group without actuator



2. Manual valve adjustment, if necessary.

A - position CLOSED

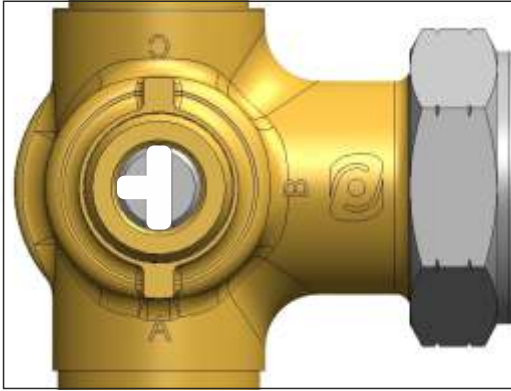

B - position OPEN

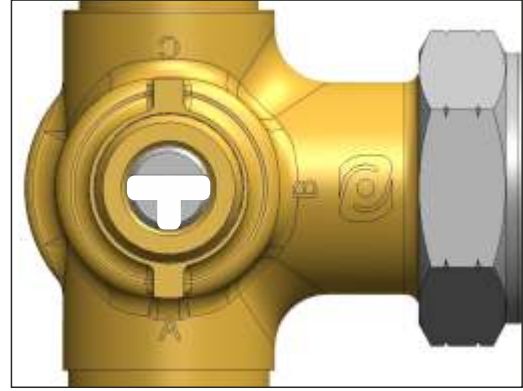

3. Installation of the actuator (returning to its place).

Adjust the part of the actuator (Y) to fits the part of the valve (Z). Pull the plastic part (X) on the back of the actuator in the direction to unlock and put the actuator part (Y) into the valve part (Z). When part of the actuator (Y) sits in the slot on the valve (Z), return the plastic (X) in the locking direction.

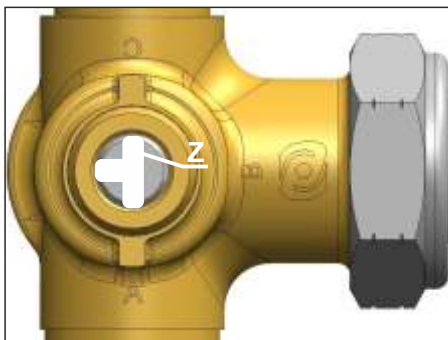
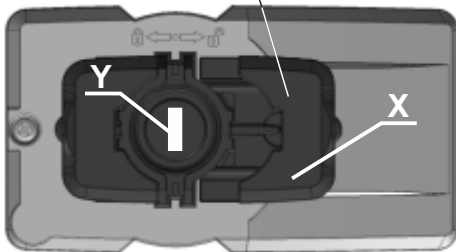
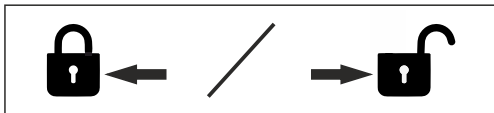

pump group with built-in actuator
in the closed position

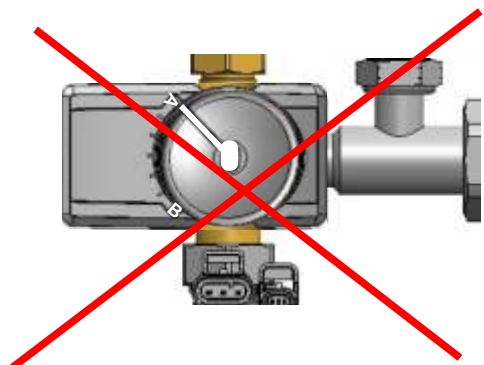
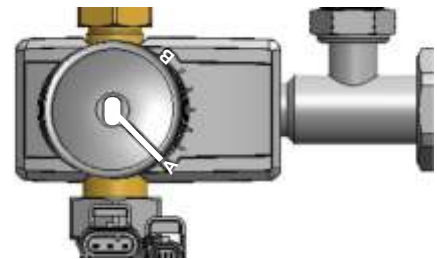

10.0. CIRCULATION PUMP INSTALLATION

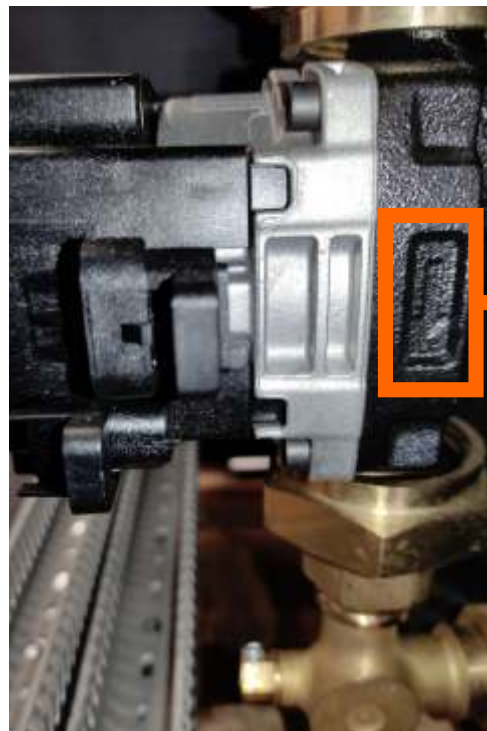
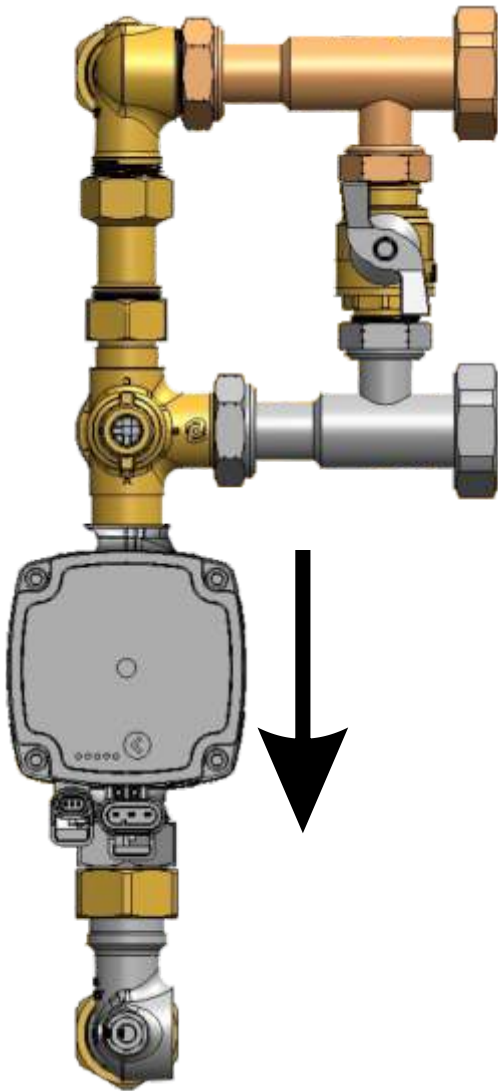

10.1. GRUNDFOS UPM3 HYBRID

10.1.1. USER INTERFACE



The user interface is designed with a single push button, one red/green LED, one green and three yellow LEDs.

User interface with one button and five LEDs.

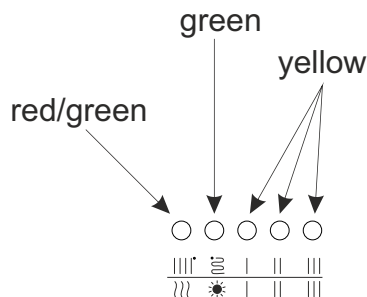
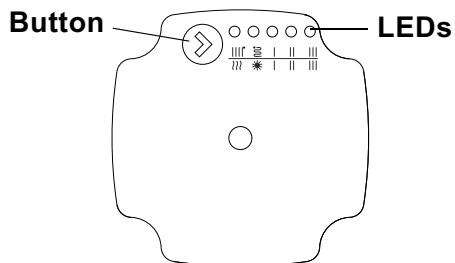

The user interface shows:

- operation status
- alarm status/errors

UPM3 HYBRID

Circulator pump is either for external PWM signal control with profile A or C (is used here), or for internal control of two operating modes with AUTO_{ADAPT.} (not used here)

10.1.2. POSSIBILITY OF ADJUSTING THE PUMP (it is recommended that the pump be operated at factory settings)

Controlling the user interface (setting the pump) is possible by pressing a button and following the display on the LED interface. The user interface displays the schedule by turning on/blinking/turning off each LED as shown in the tables below. The currently selected setting is always displayed on the interface, which can be changed with each button press.

12 blinks per second

green off yellow

FACTORY SETTING
(PWM A curve 3 signal on)

	LED1 green	LED2 green	LED3 yellow	LED4 yellow	LED5 yellow
PP AA	●	○	○	○	○
CP AA	○	●	○	○	○
PP1	●	○	●	○	○
PP2	●	○	●	●	○
PP3	●	○	●	●	●
CP1	○	●	●	○	○
CP2	○	●	●	●	○
CP3	○	●	●	●	●
CC1	○	○	●	○	○
CC2	○	○	●	●	○
CC3	○	○	●	●	●
PWM C signal off	○	☼ ¹	●	●	●
PWM C signal on	○	☼ ²	●	●	●
PWM A curve 1 signal off	☼ ¹	○	●	○	○
PWM A curve 1 signal on	☼ ²	○	●	○	○
PWM A curve 2 signal off	☼ ¹	○	●	●	○
PWM A curve 2 signal on	☼ ²	○	●	●	○
PWM A curve 3 signal off	☼ ¹	○	●	●	●
PWM A curve 3 signal on	☼ ²	○	●	●	●

☼¹ 1 blink per second

☼² 12 blinks per second

Note: Each time you press the button the pump setting changes.

10.1.3. ALARM STATUS/ERRORS

If the pump detects one of the alarms, the 2-color LED 1 changes color from green to red. When is it alarm active, LEDs show the type of alarm according to the table below. If several alarms are active at the same time, the LEDs show only the highest priority alarm. Priorities are determined according to the schedule in table. If there is no active alarm, the operating mode is displayed.

Pump screen	Meaning	Pump operation	Counter action
1 red LED + 1 yellow LED (LED 5)	Rotor is blocked.	Try to operate again.	Wait or unblock the shaft.
1 red LED + 1 yellow LED (LED 4)	Supply voltage is too low.	Only warning, pump runs.	Check supply voltage.
1 red LED + 1 yellow LED (LED 3)	Electrical failure.	Pump is stopped because supply voltage is too low or serious failure has occurred.	Check supply voltage / replace the pump.

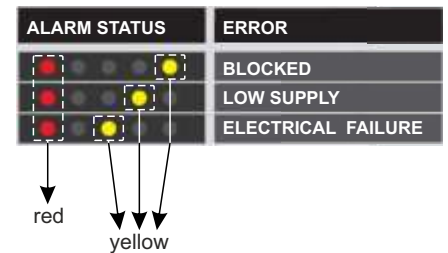

10.1.4. GRUNDFOS UPM3 ANTI BLOCKING CONCEPT

UPM3 has a double safety de-blocking system:

- deblocking software

Continuous restart after 1,33 seconds with a maximum torque of 24.8 Ncm.

- deblocking device

Manual deblocking device, accessible from front side without demounting the controller box.

Deblocking device

Deblocking device consists of an axially movable plunger secured with an O-ring and a retracted spring inside a stainless steel housing that is welded to the rotor. It is made for pumps integrated into the device so that the pump can be accessed from the front without demounting the controller box. By pushing and turning the screwdriver, the plunger pushes the shaft axially into the pump until it can rotate. The force is sufficient to unblock the pump where limescale has accumulated, for example if the device was tested wet and stored for a long time. Before, during and after unblocking, the device must tight and must not leak water.

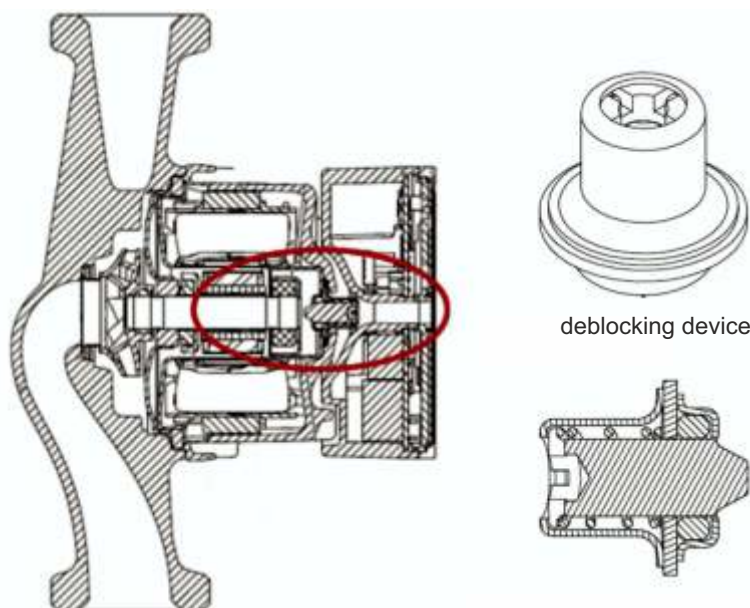

sectional drawing of deblocking device

Pump is blocked

If the pump or system is filled with water for the first time and the pump is stopped for a longer period (several weeks or months), it might happen that the pump is not able to start. The pump tries to start with a cycle every 1.33 seconds and the display shows LED 1 = red and LED 5 = yellow.

In this case, please use a screwdriver and put it in the hole in the middle of the front plate. Push it towards the pump and move it counter clockwise. Probability, the pump will start.

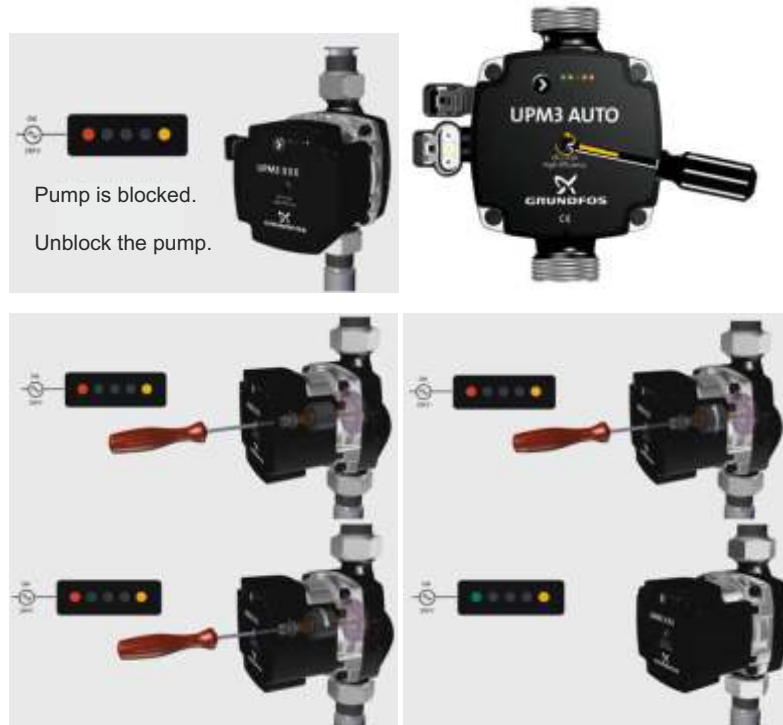

Note:

In some cases pump cannot be unblocked with screwdriver. If this happens pump must be disassembled and rotor blades must be turned (unblocked) by hand.

Error finding

ERROR	SCREEN	SOLUTION

Warning: Before starting any work at the pump, switch off the power supply. Make sure that the power supply cannot be switched on accidentally.

Warning:

This appliance can be used by children over 8 years old and persons with reduced physical, sensory or mental capabilities or lack of experience and knowledge if they are under have been given supervision or if they are given instruction concerning use of the appliance in a safe way and if they understand the involved hazards. Children must not play with the appliance. Children must not clean or maintain the device without supervision.

CORRECT DISPOSAL OF THIS PRODUCT

Your boiler is marked in accordance with Directives: 2006/42/EC, 2014/30/EU, 2014/35/EU and contains electrical components.

According to EU Regulation 2015/1189 implementing Directive 2009/125/EC with regard to Eco-Design requirements for solid fuel boilers, we draw your attention to the following:

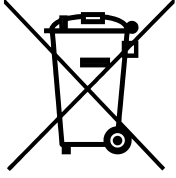

MARK FOR MARKING SEPARATE EE WASTE COLLECTION



This marking on the product indicates that the product contains electrical and electronic parts and must be disposed of separately, it must not be mixed with other waste. Your boiler is labeled in accordance with the Waste Electrical and Electronic Equipment Regulation (WEEE) and can be returned through the return and collection system available to you.

Household users should contact the retailer from whom they purchased this product, their local distributor, or their state agency for details on where and how to dispose of this product. Business users should contact their supplier and review the terms of the sales contract or contact a government agency for details on where and how to dispose of this product.

Centrometal

HEATING TECHNIQUE



Company assumes no responsibility for possible inaccuracies in this book originated typographical errors or rewriting, all the pictures and diagrams are principal and it is necessary to adjust each actual situation on the field, in any case the company reserves the right to enter their own products such modifications as considered necessary.

Centrometal d.o.o. Glavna 12, 40306 Macinec, Croatia

central tel: +385 40 372 600, fax: +385 40 372 611
service tel: +385 40 372 622, fax: +385 40 372 621

www.centrometal.hr
e-mail: servis@centrometal.hr