

ENG

TECHNICAL INSTRUCTIONS

for installation, use and maintenance
of hot water boiler and installation of
additional equipment



THE FIRST START-UP MUST BE DONE BY AUTHORIZED PERSON, OTHERWISE PRODUCT WARRANTY IS NOT VALID.



You can find the latest technical instructions
for PelTec II Lambda by scanning the
QR code or at the web address:

<https://www.centrometal.hr/en/portfolio/peltec-ii-lambda-eng/>



PelTec II Lambda 12-48

TECHNICAL INFORMATION	03
ADDITIONAL EQUIPMENT	06
1.0. INTRODUCTION	07
1.1. BOILER DESCRIPTION	07
1.2. SAFETY PRECAUTIONS	07
1.3. IMPORTANT INFORMATIONS	07
1.4. STATUS OF DELIVERY	08
1.5. MOUNTING PARTS	11
1.5.1. MOUNTING MECHANISM FOR GRATE CLEANING	12
1.5.2. SETTING PHOTOCCELL TO THE WORK POSITION	14
1.6. SAFETY ELEMENTS	15
1.7. FUEL	15
2.0. BOILER POSITIONING AND ASSEMBLY	16
2.1. MINIMUM DISTANCE FROM THE ROOM WALLS	16
2.2. OPENING FOR FRESH AIR (FRESH AIR SUPPLY)	17
3.0. CONNECTION TO A CHIMNEY	18
3.1. INSTALLATION OF THE CONNECTION FLUE GAS TUBE - THERMAL INSULATION	19
4.0. INSTALLATION	20
4.1. CONNECTION TO CENTRAL HEATING SYSTEM	20
4.1.1. CONNECTION TO OPEN HEATING SYSTEM	20
4.1.2. CONNECTION TO CLOSED HEATING SYSTEM	20
4.2. CONFIGURATION - DESCRIPTION	21
4.2.1. EXAMPLE OF SENSORS AND PUMPS CONNECTIONS	22
4.2.2. CONFIGURATION / SCHEME	23
5.0. ELECTRICAL CONNECTIONS	52
5.1. FUSES	59
5.2. ELECTRICAL SCHEME	61
6.0. OPERATING THE SYSTEM	70
6.1. SAFETY INSTRUCTIONS FOR THE INSTALLATION ROOM	70
6.2. INITIAL STARTUP	70
6.3. FILLING / REFILLING PELLET STORAGE WITH FUEL	70
6.3.1. BOILER USE	70
7.0. CLEANING AND MAINTENANCE	72
7.1. EXTRACTION OF TURBULATORS - PelTec II Lambda 12-48	76
7.2. REPLACEMENT OF THE ELECTRIC HEATER WITH NEW ELECTRIC HEATER	77
7.3. CLEANING OF PELLET TANK AND SCREW FEEDER (TRANSPORTER)	79
8.0. CIRCULATOR PUMP INSTALLATION	82
8.1. GRUNDFOS UPM3 HYBRID (25-70)	82
8.1.1. USER INTERFACE	82
8.1.2. POSSIBILITY OF ADJUSTING THE PUMP	83
8.1.3. ALARM STATUS/ERRORS	84
8.1.4. GRUNDFOS UPM3 ANTI BLOCKING CONCEPT	84
9.0. CHANGING THE BOILER CONTROL UNIT SCREEN BATTERY (CR 1632)	86
CORRECT DISPOSAL OF THIS PRODUCT	87

TECHNICAL INFORMATION

Model identifier (TYPE):	PelTec II Lambda 12	PelTec II Lambda 18	PelTec II Lambda 24	PelTec II Lambda 36	PelTec II Lambda 48	
Useful heat output at rated heat output - P _n (kW)	12	18	24	36	48	
Useful heat output at 30 % of rated heat output - P _p (kW)	3.6	5.4	7.2	10.8	14.4	
Useful efficiency at rated heat output (Net calorific value "NCVar") (%)	93.8	93.9	94.1	92.8	91.5	
Useful efficiency at 30 % of rated heat output (Net calorific value "NCVar") (%)	90.7	92.1	93.5	94.2	94.9	
Useful efficiency at rated heat output (Gross calorific value "GCVar") - η _n (%)	86.4	86.5	86.7	85.5	84.3	
Useful efficiency at 30 % of rated heat output (Gross calorific value "GCVar") - η _p (%)	83.4	84.9	86.1	86.8	87.4	
Heat output range (kW)	3.6-12	5.4-18	7.2-24	10.8-36	14.4-48	
Boiler class	5					
Required chimney underpressure (mbar)	0,02					
Water amount in boiler (l)	78	76	100	108	135	
Exhaust gas temperature at nominal heat output (°C)	130					
Exhaust gas temperature at minimal heat output (°C)	100					
Exhaust mass flow at nominal heat output (g/s)	15.16	18.97	22.78	35.27	47.75	
Exhaust mass flow at minimal heat output (g/s)	5.82	6.91	8.0	13.1	18.05	
Operating (combustion) time (h)	-					
Min. inlet water tem. at the boiler supply water connection (°C)	-					
Setting range for temperature controller (°C)	65-90					
Minimum return flow temperature (°C)	> 0°C					
Heat loss when the boiler is OFF (W)	-					
Boiler resistance on water side at nominal output *** (mbar)	0.025	0.055	0.095	0.205	0.37	
Fuel size (mm)	Ø6 x 50					
Fuel loading chamber capacity (l)	0.96	0.96	1.59	2.56	2.56	
Fuel loading chamber dimensions (mm)	465x300x300	650x300x300	650x300x300	620x385x385	770x385x385	
Combustion chamber volume (l)	41.85	58.5	58.5	91.90	114.13	
Combustion chamber type	underpressure					
Pellet tank volume (l)	340	340	340	340	340	
Ash box volume (left/right) (l)	9.9 / -	6.5 / 9.9	9.9 / 9.9	11.6 / 17.7	13 / 19.6	
Auxiliary power requirements at Q _n (W)	1050	1050	1050	1100	1100	
Auxiliary power requirements at Q _{min} (W)	-					
Supply voltage (V~)	230					
Frequency (Hz)	50					
Boiler body dimensions	Length (A) (mm)	1100	1090	1050	1150	1150
	Width (B) (mm)	1210	1435	1380	1465	1465
	Height (C) (mm)	1560	1560	1560	1560	1560
Total mass - (boiler with tank and screw feeder) (kg)	328	349	402	455	478	
Max. operating overpressure (bar)	2.5					
Test pressure (bar)	5					
Max. operating temperature (°C)	90					
Flue gas tube - external diameter (mm)	130	130	130	150	150	
Dimension D*/D** (mm)	1515 / 1230	1040 / 755	1140 / 850	1155 / 835	1305 / 935	
Dimension E (mm)	125	120	120	125	125	
Dimension F (mm)	525	525	520	520	670	
Boiler connections	Main/return flow (thread) (G)	5/4"	5/4"	5/4"	5/4"	
	Filling/drainage (thread) (G)	1/2"				
Heating appliance working	with fan					
Heating appliance working	under non-condensing conditions					
Stoking mode	automatic					
The boiler should be operated with a hot water storage tank of a volume of at least (l)	240	360	480	720	960	
Condensing boiler	no					
Solid fuel cogeneration boiler	no					
Combination boiler	yes					
Preferred fuel	compressed wood in the form of pellets: C1 (EN 303-5:2021+A1:2022); A1 (EN ISO 17225-2)					
Seasonal space heating energy efficiency - η _s (%)	79	80	82	83	83	
Seasonal space heating emissions for preferred fuel ****	PM mg/m ³ (10% O ₂)	19	21	23	22	21
	OGC mg/m ³ (10% O ₂)	5	3	2	2	2
	CO mg/m ³ (10% O ₂)	167	117	67	90	113
	NO _x mg/m ³ (10% O ₂)	138	138	138	139	141
Auxiliary electricity consumption	At rated heat output - e _{l,max} (kW)	0.055	0.066	0.076	0.086	0.096
	At 30 % of rated heat output - e _{l,min} (kW)	0.039	0.039	0.039	0.043	0.046
	Of incorporated secondary emission abatement equipment (kW)	Not applicable				
	In standby mode - P _{SB} (kW)	0.009				
Boiler category	1					

* possible way of installing the fan (output is directed up)

** possible way of installing the fan (output is directed sideways)

*** dT=20°C

 **** PM = particulate matter, OGC = organic gaseous compounds, CO = carbon monoxide, NO_x = nitrogen oxides

Contact details: Centrometal d.o.o. - Glavna 12, 40306 Macinec, Croatia

Technical data

Dimensions of the boiler to enter the room	12 kW	18 kW	24 kW	36 kW	48 kW
Width (G)	660	880	855	945	945
Depth (H)	760	760	740	840	840
Height (I)	1560	1290	1270	1270	1420
Min. room height for turbulators removing (J)	1900	1700	1700	1700	2000

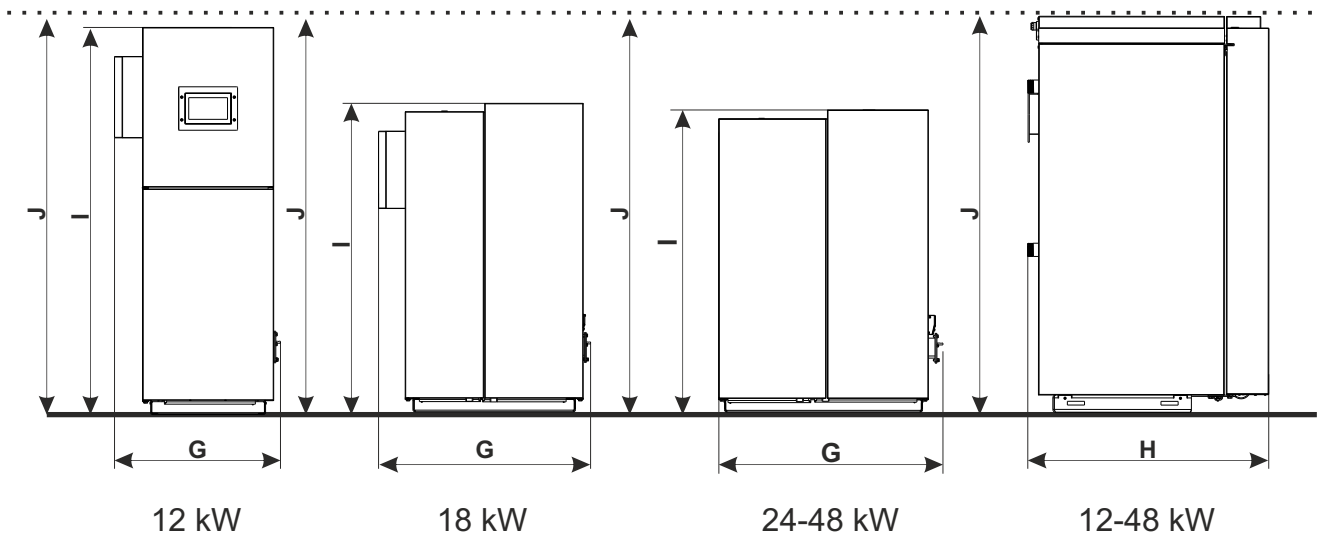

BKU - Boiler control unit box
DP - Flue gas tube
FC - Flexible PVC tube
PE - Connection for expansion vessel
PG - Pump group
PLV - Boiler main flow
PP - Charge / Discharge
PT - Pellet feeder (transporter)

PVV - Boiler return flow
RE - Boiler control unit screen (7")
RP - Pellet level sensor
SG¹ - Safety airvent group (not included in delivery)
SP - Pellet tank
TU - Temperature sensor tube (probe) (return and main flow)
VE - Fan (fan output can be mounted in any directions)

Front view

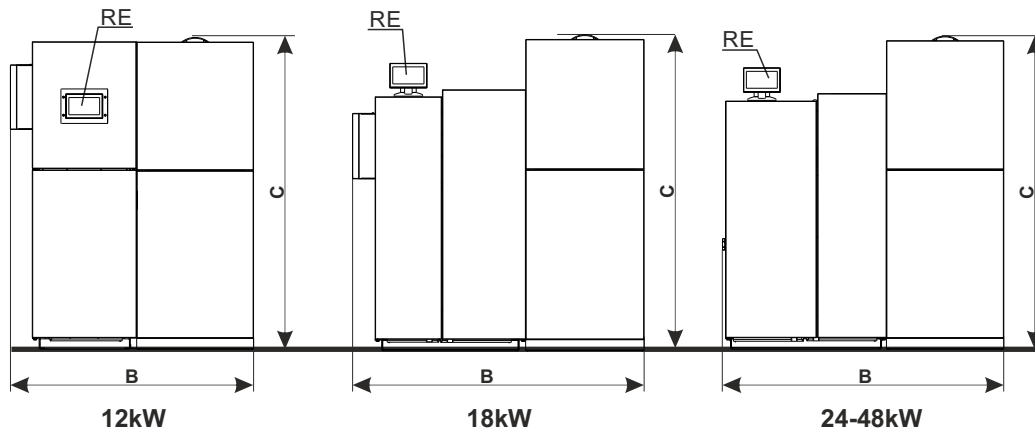

Side view

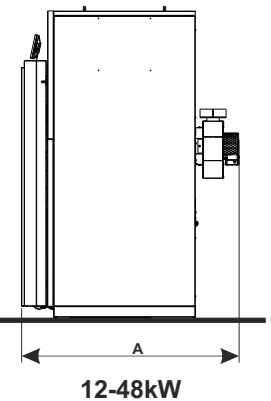

Back view - PelTec II Lambda 12-48

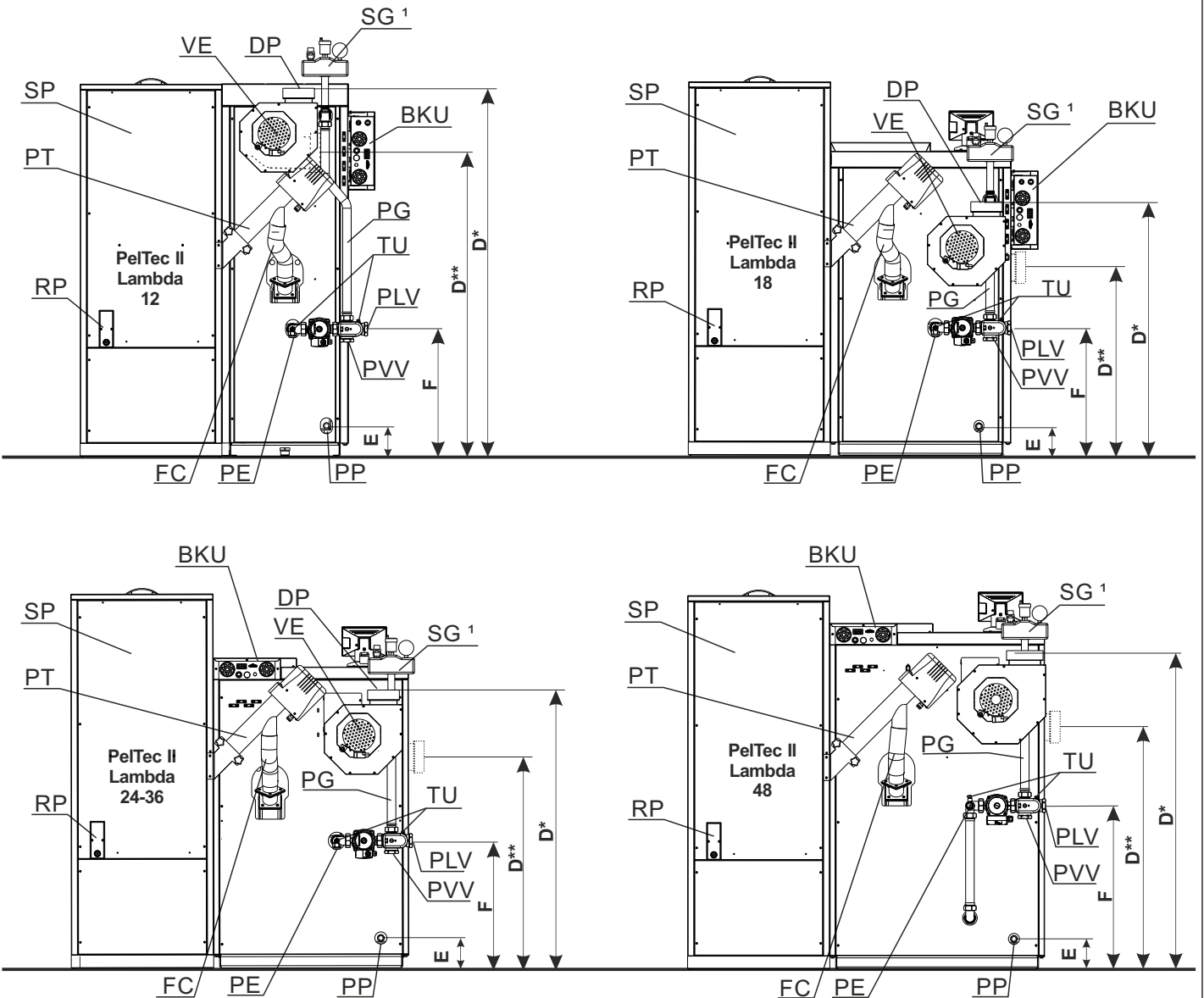

* possible way of installing the fan (output is directed up)
 ** possible way of installing the fan (output is directed sideways)

¹ not included in delivery

Basic parts and sensors, additional equipment

- 1 - Boiler sensor (NTC 5k)
- 2 - Heating circuit K1/K2 temperature sensor /
accumulation (buffer) tank temperature sensor /
Hydraulic crossover temperature sensor (NTC 5k)
- 3 - Pressure switch
- 4 - Photocell
- 5 - Electric heater
- 6 - Flue gas temperature sensor (Pt 1000)
- 7 - Fan speed sensor

- 8 - PVC tube bimetal sensor
- 9 - Pellet level in the tank
- 10 - Heating circuit K1/K2 temperature sensor /
accumulation (buffer) tank temperature sensor /
Hydraulic crossover temperature sensor (NTC 5k)
- 11 - Return flow sensor (NTC 5k)
- 12 - Lambda probe
- 13 - Outdoor temperature sensor (NTC 5k)
- 14 - Main flow sensor (NTC 5k)

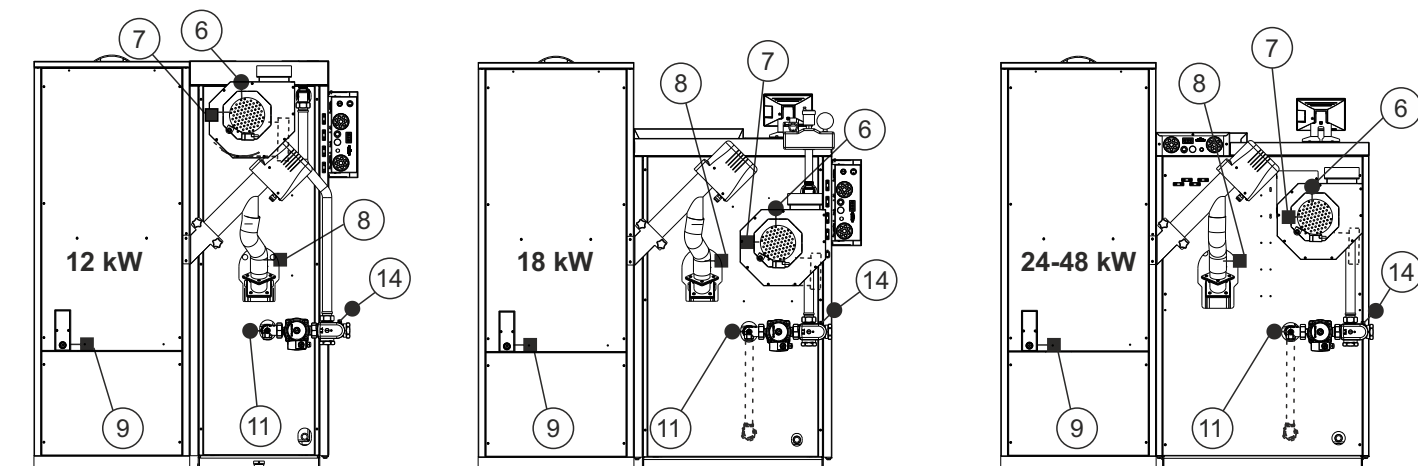
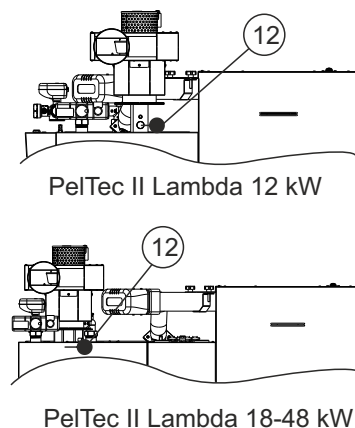
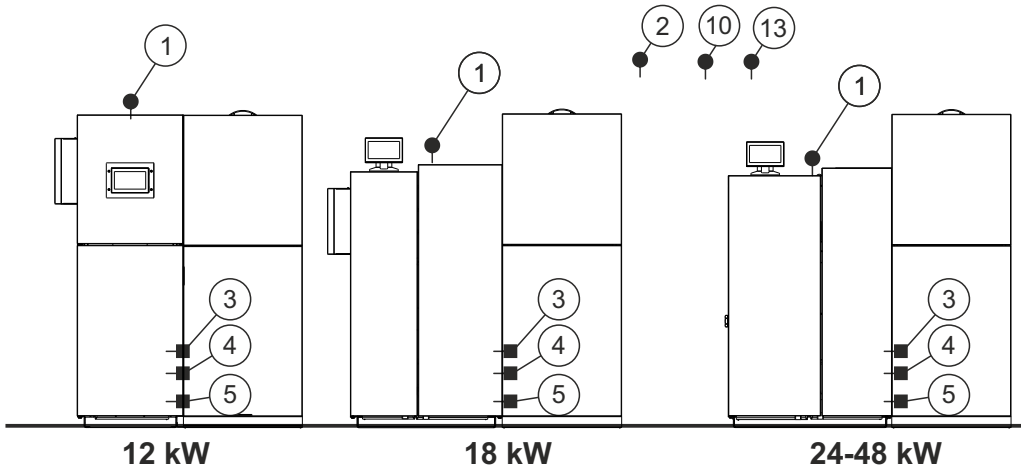

ADDITIONAL EQUIPMENT

CAL - alarm box (speaker/ LED)



CM2K module for regulation 2+ heating circuits



CMNET module for boiler cascade



Pellet suction system



Increasing volume of pellet tank (+77kg, h=300mm) (12-48 kW)

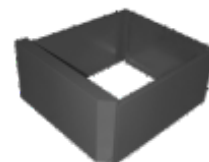

Screw refill (CPSP-BP 800 - System for the pellet supply by the screw transporter from 800 lit. pellet tank)

Room corrector (CSK-Touch)



Room corrector (CSK)



Rotary valve (12 - 48 kW)



1.0. INTRODUCTION

The **PelTec II Lambda** has a modern construction and design and is made out of the controlled materials of high quality, welded with most modern technology and is approved and tested under EN 303-5 norm and fulfil all special request for the connection on the installation of a central heating system.

1.1. BOILER DESCRIPTION

Steel hot water boiler are engineered for wood pellet firing. In the boiler is installed the burner for wood pellet firing with the automatic firing and automatic self-cleaning function which enables the reliable operation also with the low quality wood pellets. The function of the automatic cleaning flue gas tubes provides the unifying exchange of the heat and high and unifying level of boiler efficiency. Digital boiler control unit in a basic construction offers also the possibility of control with the lambda probe or level control of the wood pellets in the pellet tank. The pellet tank is the integral part of the boiler. The boiler is delivered in pieces due to the easier transport into the boiler room.

1.2. SAFETY PRECAUTIONS

The boiler and related accessories are state of the art and meet all applicable safety regulations. The control unit, wiring chamber, el. heater, safety cut-out STB thermostat, fan, grid cleaning mechanism, flue gas tubes cleaning mechanism and pellet supply mechanism are integrated into the **PelTec II Lambda**. They are operate at a voltage of 230 V AC. Improper installation or repair can pose the danger of life-threatening electric shock. Installation may be performed only by appropriately qualified technicians.

Caution symbols:

Please take careful note of the following symbols in this technical instructions.



This symbol indicates measures for protection against accidents and warning for the user and / or exposed persons.

1.3. IMPORTANT INFORMATIONS

All local regulations, including those referring to national and European standards need to be complied with when installing the appliance. The boiler must not be modified unless using the tested original accessories we provide or if the work is undertaken by our Customer Service. Only fit original spare parts. These can be obtained from your customer service partner or directly from ourselves. European standards need to be complied with when installing the appliance. Regular care and cleaning of the appliance, flue gas outlets, connecting piece and flue.



CAUTION:

The flue may block if the boiler is heated again after a long period of it not being used. Before starting the boiler, have the flue checked by a specialist (chimney sweep). Ensure sufficient supply of fresh air in the installation room when heating. The air must be replaced at least 0.8 times an hour through constant and reliable room venting. Fresh air may have to be provided from outside if the windows and doors in the room where the boiler is installed are well sealed or if this room contains other equipment, such as extractor hoods, clothes dryer, fan etc.

1.4. STATUS OF DELIVERY

Equipment is delivered seperately:

1. Boiler with cover and thermal insulation.

With inbuilt and pre-wired:

- color touch screen display (7") of boiler control unit (only pre-wired except for PelTec II Lambda 12 which is factory installed).

- boiler temperature sensor - NTC 5K - PVC I=1000 (12041).

- flue gas temperature sensor - PT 1000 - Teflon I=1700 (62330).

- lambda probe.

Boiler control unit screen (7") - touch-sensitive color display (supplied in the boiler ash box, except for the PelTec II Lambda 12 where it is factory installed).

Display holder (supplied in the boiler ash box, except for PelTec II Lambda 12 where it is factory installed).

Additional parts, sensors and connectors in basic delivery:

- 1 x return flow temperature sensor - NTC 5K - PVC I=2000 (26226).

- 1 x (Heating circuit K1/K2 temperature sensor / Acc. (buffer) tank temperature sensor / Hydraulic crossover temperature sensor) - NTC 5K - PVC I=2000 (26226).

- 1 x (Heating circuit K1/K2 temperature sensor / Acc. (buffer) tank temperature sensor / Hydraulic crossover temperature sensor) - NTC 5K - PVC I=2000 (32685)

- 1 x outdoor temperature sensor - NTC 5K (31428).

2. Pellet tank in a cardboard box (the parts need to be mounted, see instructions for mounting the pellet tank).

3. Feeder screw with a flexible PVC tube (should be placed in the pellet tank).

4. Grate cleaning mechanism (requires installation on the boiler).

5. Fan (requires installation on the boiler).

6. Pump group (Tubes with 4-way mixing valve with actuator and circulation pump (need to be mounted on boiler).

7. Thermal insulation of the connection flue gas tube between fan and chimney.

8. Cleaning tools: scraper, wooden cleaning brush, wire cleaning brush.

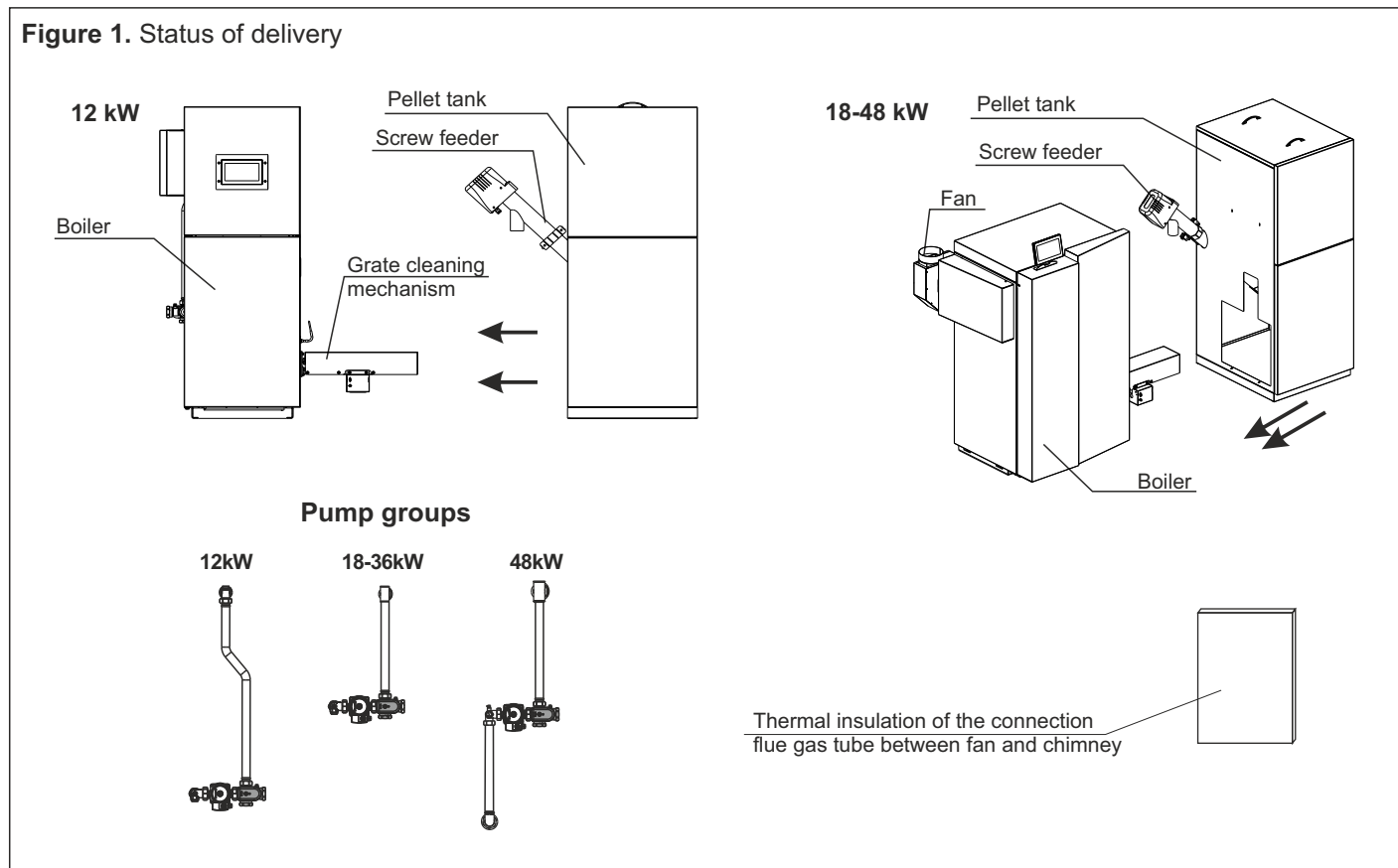

Pump group

- mount pump group with 4-way mixing valve to the boiler so that the T-piece is in the upper side. On the upper connector of the T-piece incorporate safety ventilation group. On the back of boiler were prepared two holenders for mounting connection tubes (connection tubes with 4-way mixing valve). Be sure to use the seal for holenders. Set return temperature sensor in the socket for the sensor between the 4-way mixing valve and the boiler. It is obligatory using the included thermal paste. Plug-in return flow sensor on the back of the box control. Connect the pump cable with connector to the back of the controller box. **Mandatory** set the 3-speed pump on the speed 3 or max. power for HE pumps.

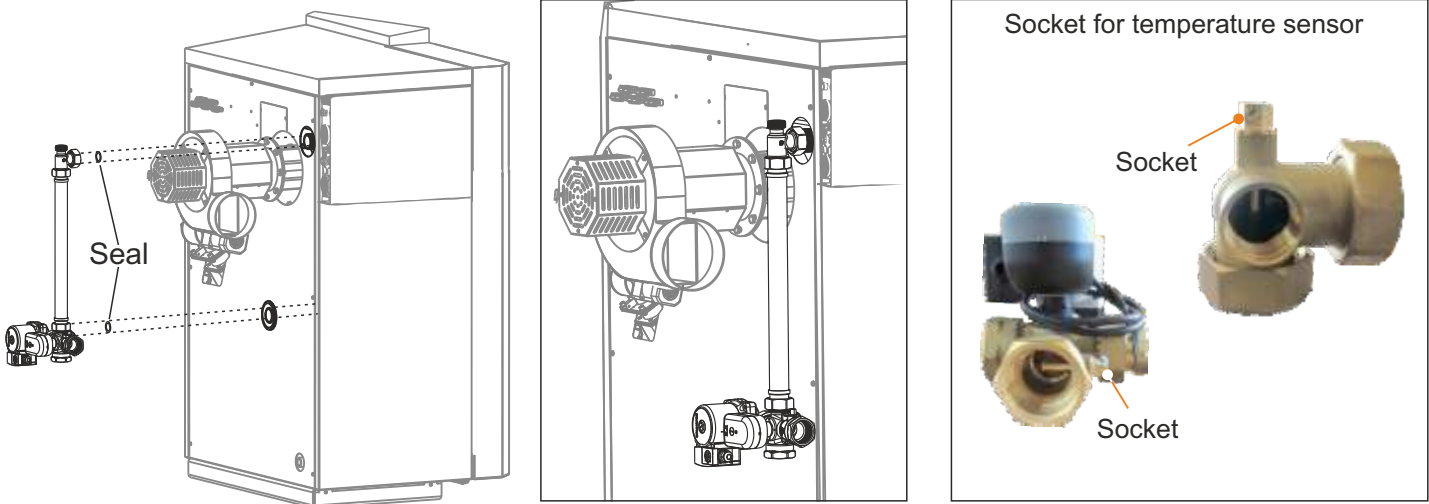

Example of installation pump group to the boiler PelTec II Lambda 18-36

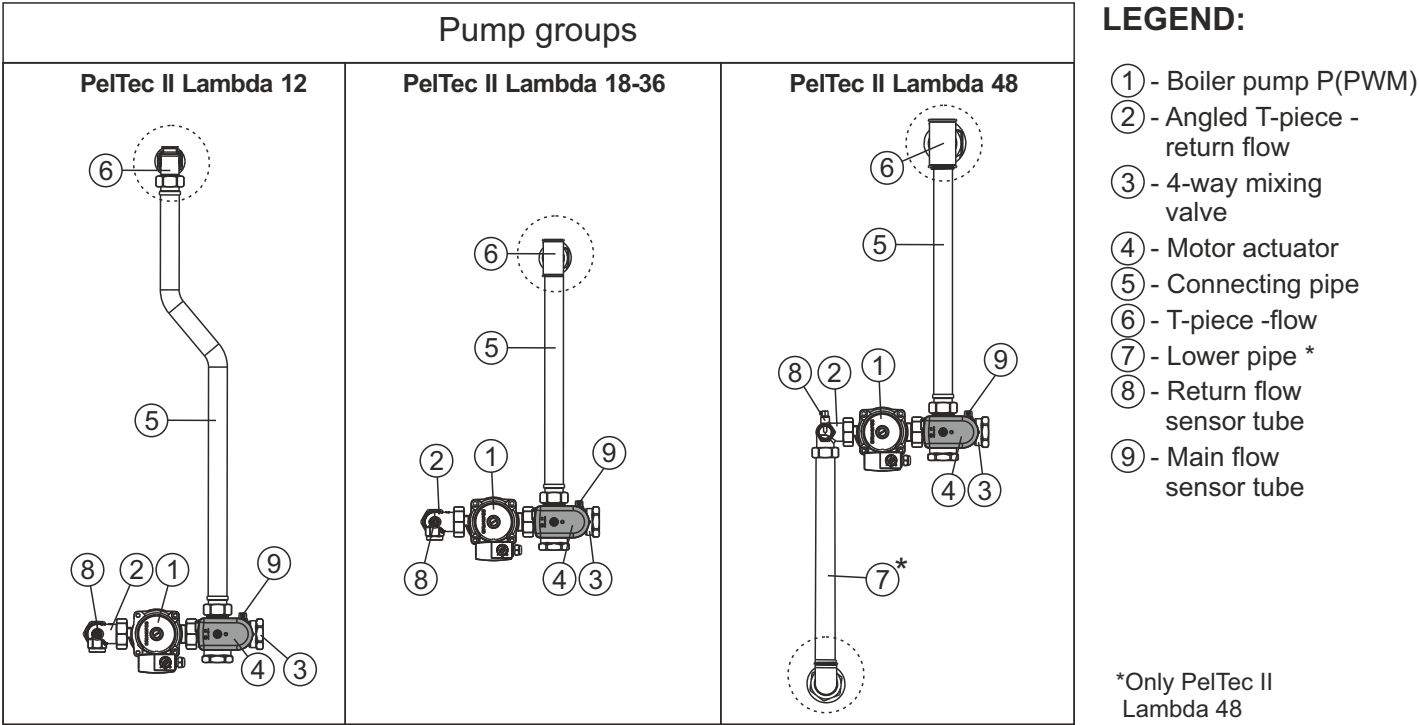

NOTE: check the tightness of connection tubes. Fasten connections binding tubes if necessary, so that a good seal.

Pellet tank

- mount pellet tank according installation manual for mounting pellet tank. Set up feeder screw (pellet transporter) in the pellet tank. Place the pellet tank to the boiler and set PVC tube to feeder screw (pellet transporter) and tube supply on the boiler. Set up the PVC tube so as to allow the smooth falling pellet into the burner. If necessary, cut the PVC tube to the required length. Plug-in the power connector on the back of the boiler control unit box.

Pellet level sensor in the pellet tank

- The pellet level sensor for the pellet level in the tank comes factory installed on the back of the pellet tank with a factory installed cable and connector to connect to the rear of the boiler control unit box. After the tank is mounted and placed in the place next to the boiler, it is necessary to connect the cable with the connector into the specific position on the back of the boiler control unit box (see figure 4).

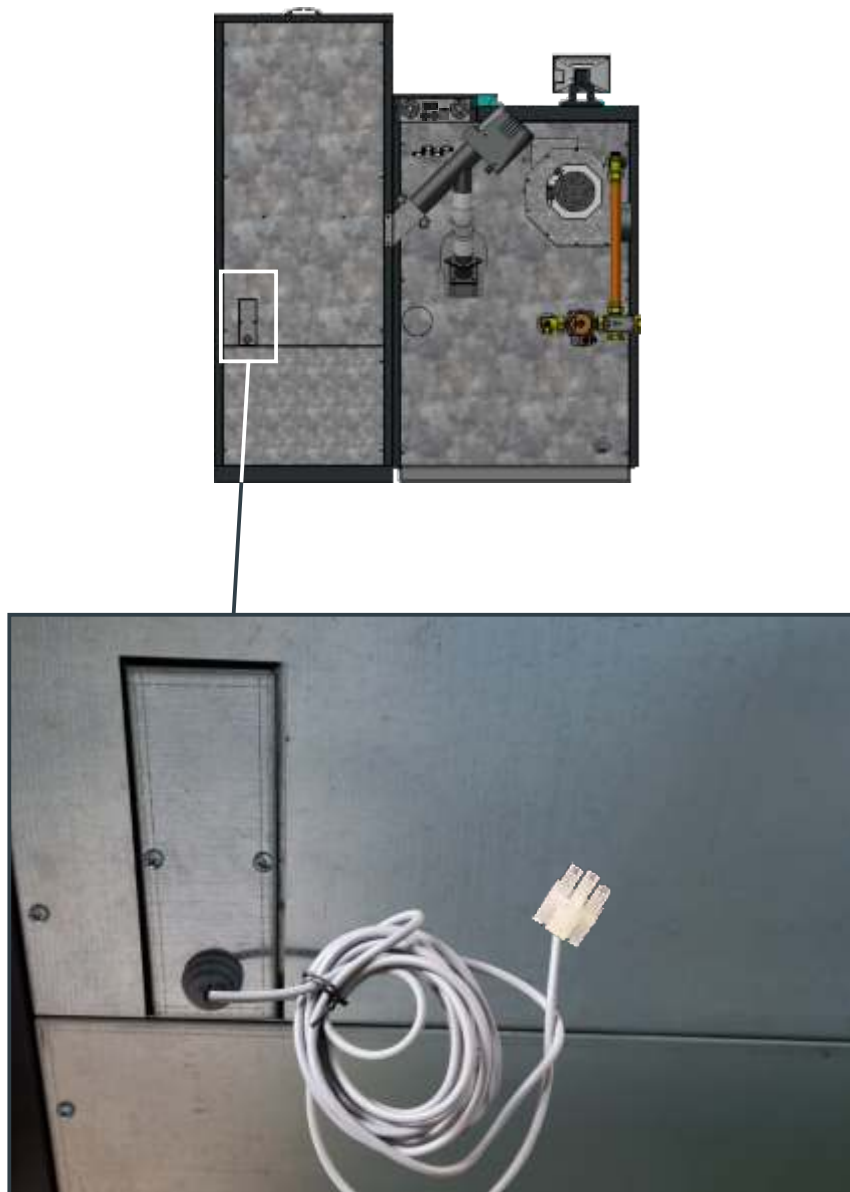

1.5. MOUNTING PARTS

For ease of handling, transport and import of boiler, PeITec II Lambda is delivered in parts that need be mounted on the boiler when the boiler is in the boiler room. These parts need to be installed on the boiler:

Fan

- mount on the back of boiler, is obligatory to use the flange gaskets fan, fastened using bolts and nuts. The electrical connector for the fan and RPM sensor is connected directly to the boiler control unit box. Fan output can be mounted in any directions.

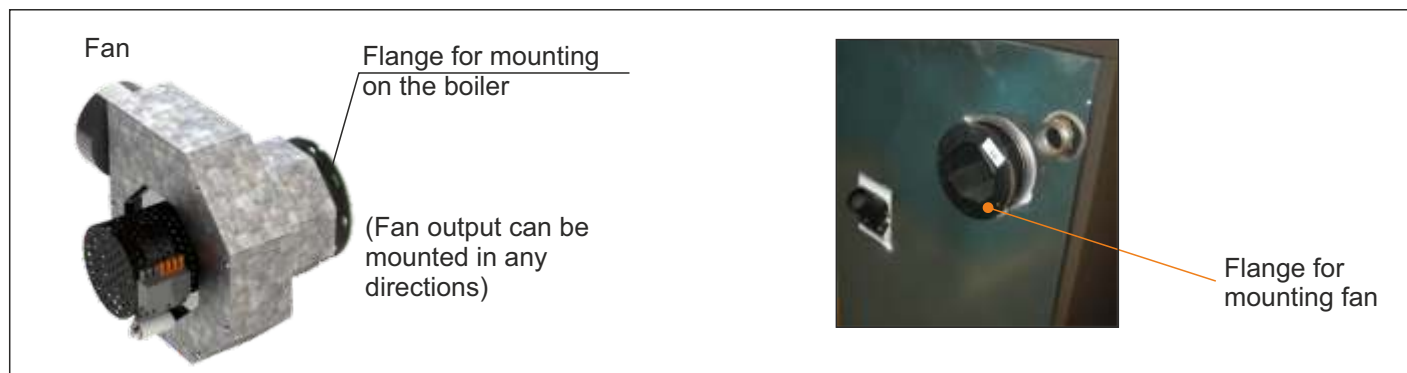

Mechanism for grating cleaning

- mount on the right side of the boiler (in this side is pellet tank), must be fastened using two M8 bolts and nuts. After assembly, it is necessary to attach the lever burner grid with gear motor trail. Plug-in two cables with connectors (motor and microswitches).

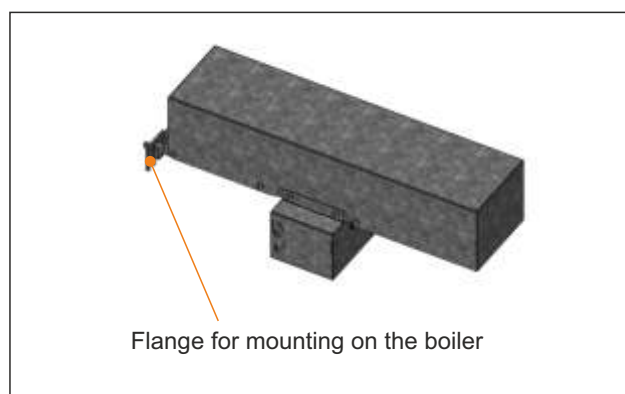
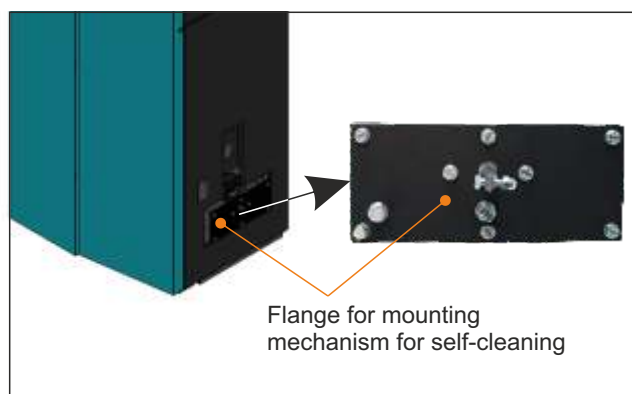

1.5.1. MOUNTING MECHANISM FOR GRATE CLEANING

1. Remove the three screws (A), from cover (B) of the grate cleaning mechanism and remove cover carefully.

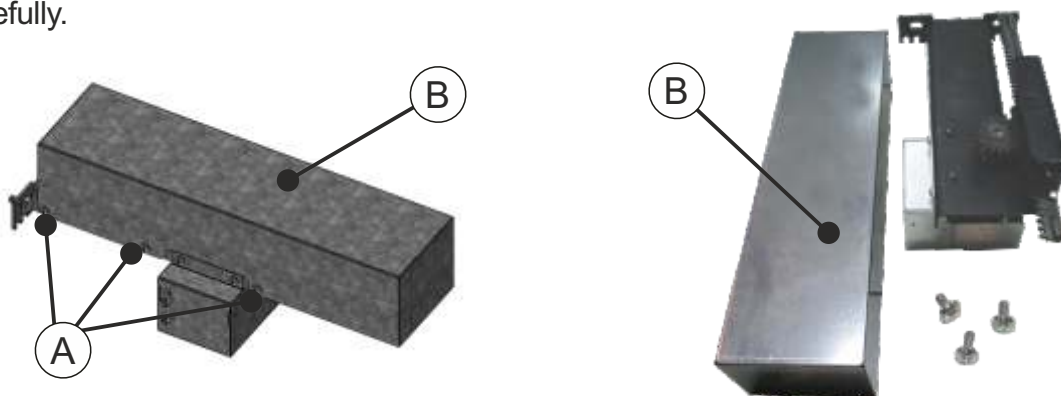

2. Remove the two screws (C) and just slightly loosen screws (D) as shown in picture below. Carefully attach grate cleaning mechanism to loose screws (D), then fasten with screws (C) and tighten the screws (D).

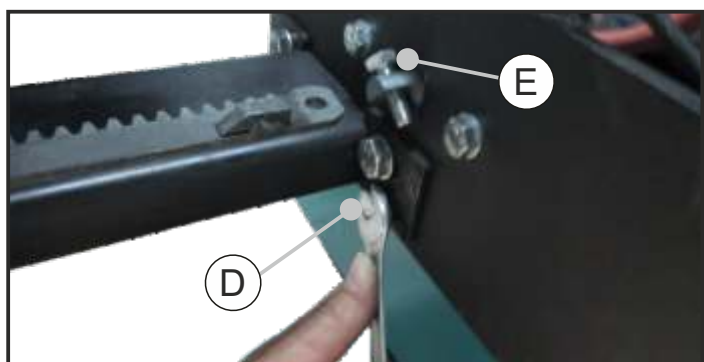
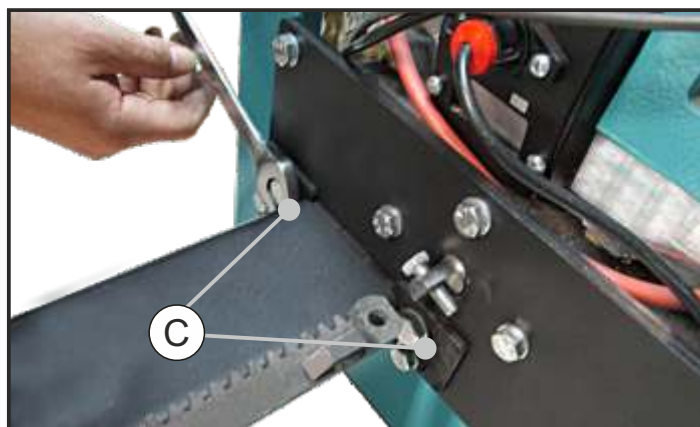
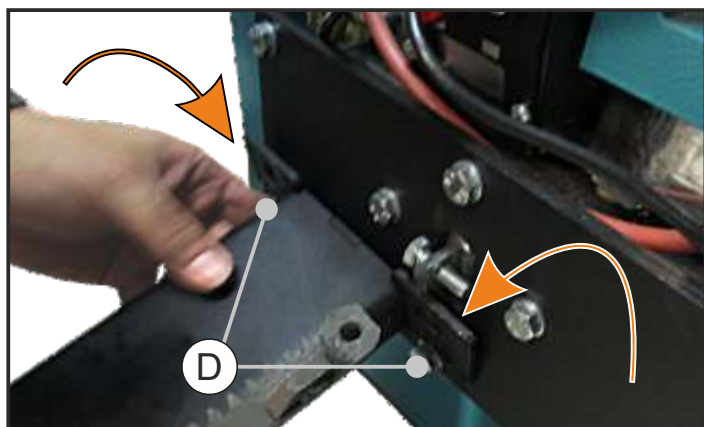
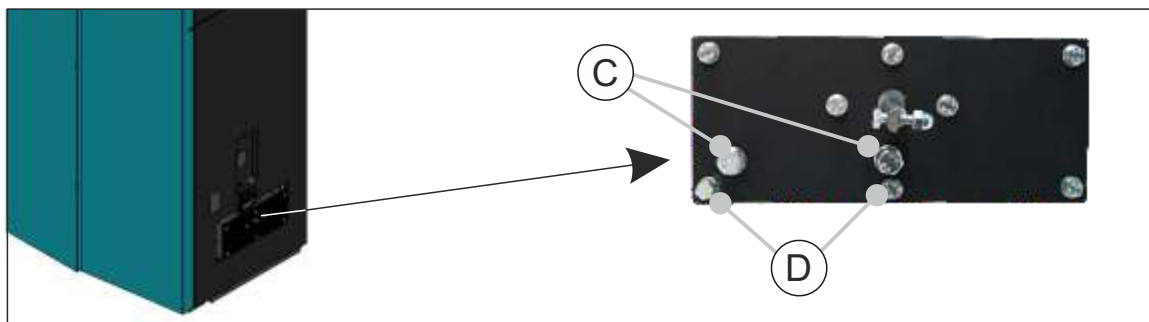

3. Set the screw (E) into the jagged track (F), set the nut on the screw and tighten. Free space (G) is required for the proper functioning of the mechanism.

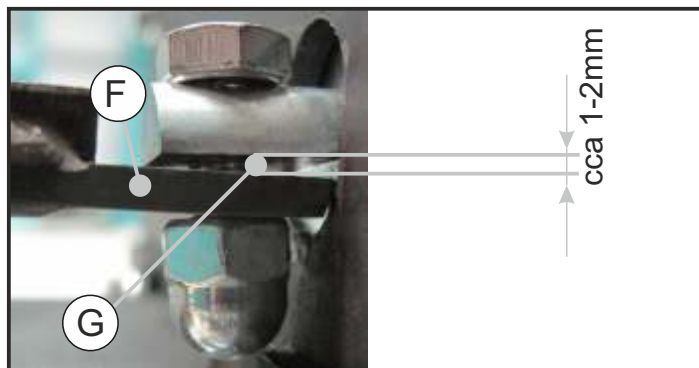
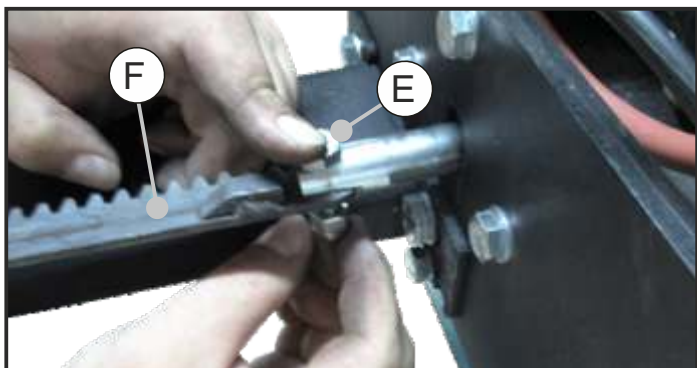

4. Connect the connectors (H and I with J and K) so they have a good contact.

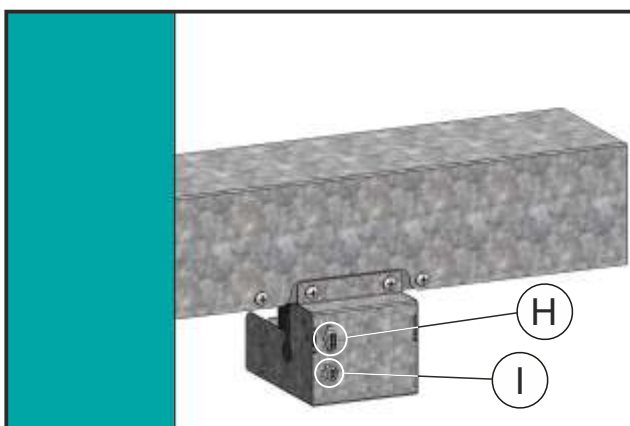

Detail H
(3P - female)

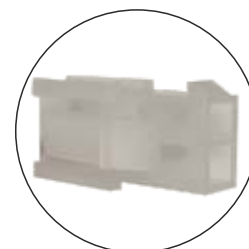

Detail I
(2P - female)

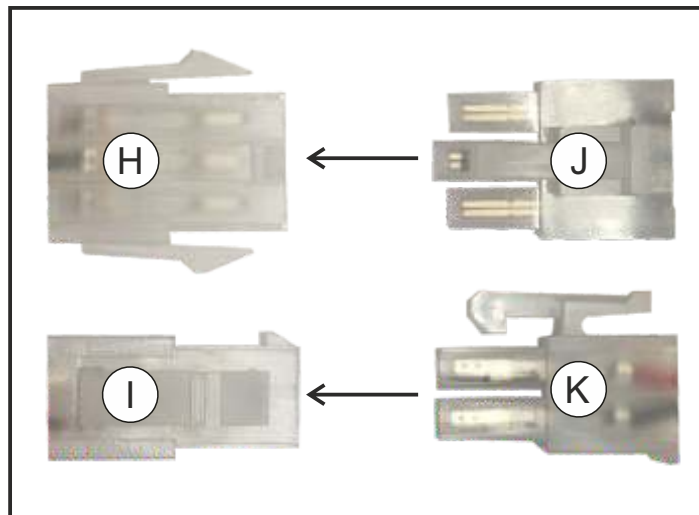
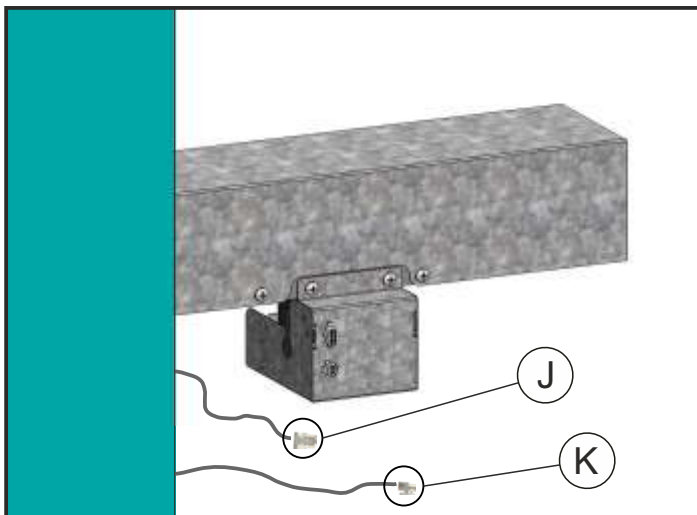

5. Carefully set the cover and tighten with the screws (A).

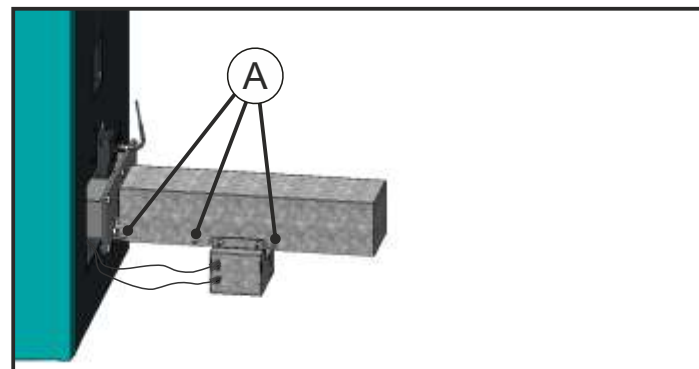

1.5.2. SETTING PHOTOCELL TO THE WORK POSITION



Before first startup, be sure to set the photocell to the position as on the figures below, otherwise the boiler will not work properly!

The photocell should not be set too deep or too shallow in the box. Because of this, there is an limiter by which correct photocell dept is set. Check if the limiter is adjusted according to the photos below.

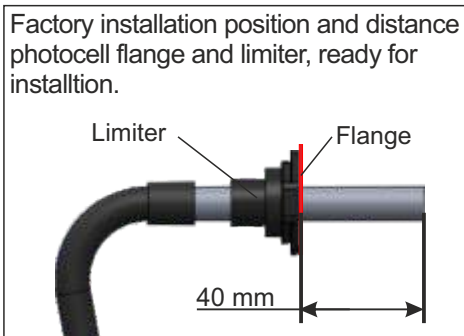

Carefully install photocell into flange on the box to the limiter (so it clicks)



Correctly installed photocell
Boiler ready for operation



1.6. SAFETY ELEMENTS

Boiler have a few safety elements:

- **Bimetal thermostat** - built on the burner pellet feeding tube. If the bimetal set temperature (80°C) is exceeded, pellet feeding is stopped, the boiler stops working and the E8, E8-1 or E8-2 and "Pellet supply tube temperature too high" are displayed on the boiler control unit screen.
- **Pressure switch** - if there is no underpressure in the boiler (eg. chimney is not passable, any boiler door or cleaning opening is open or the PVC pellet supply pipe is punctured), the controller displayed E12 and "Safety pressure switch", and the boiler stops working.
- **Photocell** - in case there is no flame (photocell does not see flame) in the ignition phase at the set time, the controller displays E18 and "No flame in ignition stage" and stops the boiler, if the flame disappears in the ignition phase, the control displays E23 and "Flame disappeared in ignition stage" and stops the operation of the boiler, if the flame disappears in the stabilization phases, the controller displays E24 and "Flame disappeared stabilization stage" and stops the boiler, and if the flame disappears in the phases of boiler operation, the controller displays E19 and "Flame disappeared working phase" and stops the boiler operation.
- **Controller** has a built in protective function which protects the boiler against overheating. If temperature in the boiler exceeds 93 °C, the all pump turns on and works until temperature in the boiler falls below 93 °C.
- **The fan** has a built-in RPM counter and, if regulation is informed that the fan does not operate in accordance with the requirement interrupts the process display error E13 and "Fan error".
- **The grate cleaning mechanism** has two built-in microswitches that monitor the position of the grate. If the grate is not in the required position at a certain moment, the controller receives this information and interrupts the operation process, and E21 and "Error grate cleaner" will appear on the display.
- **Flue gas connection** have in-built sensor for flue gas temperature measuring. If flue gas tube temperature is over 300 °C, controller interrupt proces and display information E4 and "Flue gas sensor error".
- **STB thermostat** - When temperature in the boiler exceeds 110 °C (+0 °C / - 9 °C), power supply is turned off by the safety thermostat (STB).
- **Thermal protection** (built in coils of the fan electric motor at the burner and the screw feeder motor, flue pipe cleaning, grate cleaning) protects them against overheating caused by failure or locking.
- **Flexible PVC tube** connecting the pellet burner and pellet tank is made of plastic material reinforced with metal wire which, in case of back flame from the burner to the tank, melts and prevents flame to penetrate to the pellet tank.

1.7. FUEL

Only wood pellets are used as fuel in PelTec II Lambda. Wooden pellets are bio-fuel made of wooden wastes. Pellets can be packed in different packaging: in bags (15 kg or 1000 kg), or as bulk in large (underground) tanks (4 - 15 m³) or in basement spaces. Pellets used in pellet boiler must be in accordance with following norms: ENplusA1, DINplus, ONorm-M-7135 or DIN 51731.

Recommended properties of pellets are following:

- heating value \geq **5 kWh/kg** (18 MJ/kg)
- diameter \leq **6 mm**
- max. length = **50 mm**
- max. moisture content \leq **12 %**
- max. dust content \leq **1,5 %**.

2.0. BOILER POSITIONING AND ASSEMBLY

Boiler positioning, assembly and building in must be performed by a qualified person. We recommend that boiler is placed on a concrete base with height of 50 to 100 mm above the floor. Boiler room must be frost-proof and well ventilated. Boiler has to be positioned so that it can be properly connected to the chimney (see Figure 2a) and simultaneously, enabling tending of boiler and additional equipment, control during operation, cleaning and maintenance.

WARNING!

Flammable items must not be placed on the boiler and within the minimum distances shown in Figure 2a and 2b.

2.1. MINIMUM DISTANCE FROM THE ROOM WALLS

Figure 2a. Minimum distance from the room walls for PelTec II Lambda

PelTec II Lambda 12-48

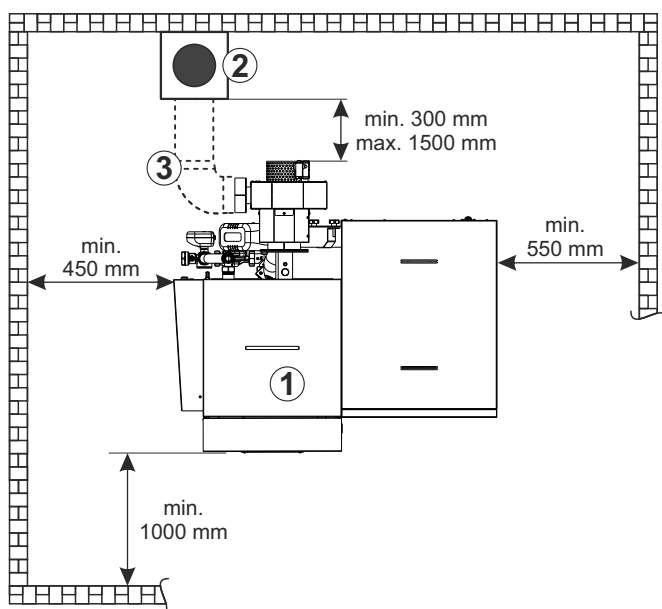

- ① - Boiler PelTec II Lambda
- ② - Chimney
- ③ - Flue gas tube (Chimney connection; must be insulated)



Provide minimum distance from the boiler room ceiling and walls for undisturbed cleaning.

Figure 2b. Minimum distance from the boiler room ceiling.

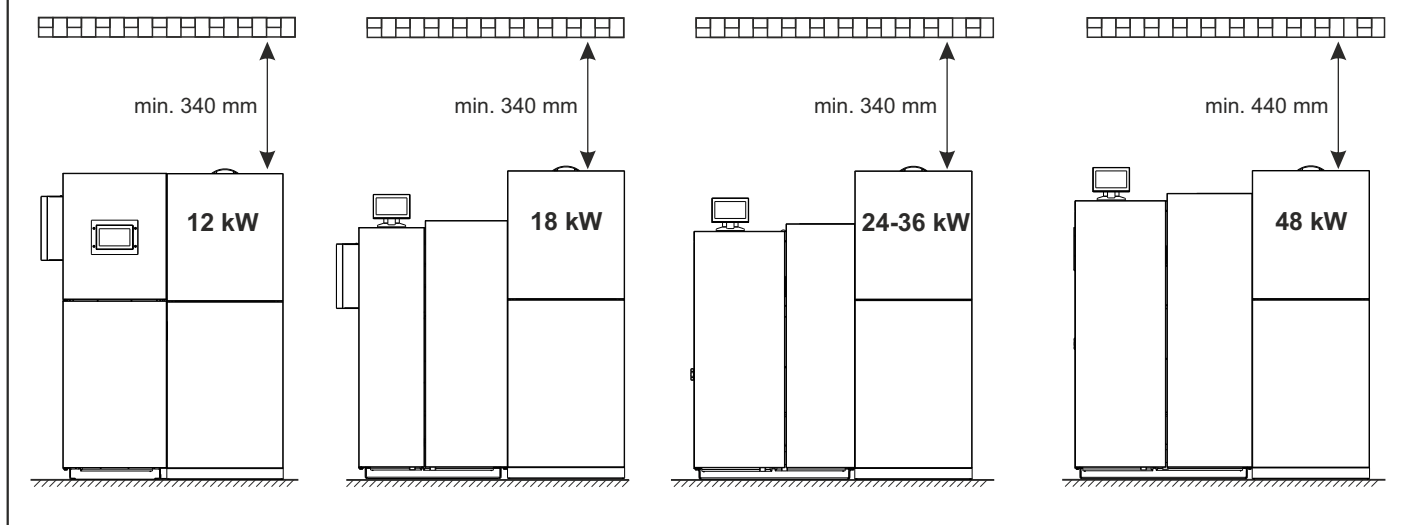

2.2. OPENING FOR FRESH AIR (FRESH AIR SUPPLY)

Each boiler room **must be equipped with an opening** for supply of fresh air which is dimensioned in accordance with boiler output (minimum opening area according to the below shown equation). Such opening must be protected with a net or grate. All installation works have to be performed in accordance with valid national and European standards. Boiler must not operate in flammable and explosive environment.

$$A = 6,02 \times Q$$

A - opening area in cm^2
Q - boiler output in kW

3.0. CONNECTION TO A CHIMNEY

Properly dimensioned and built chimney is the main condition for safe and economical functioning of the boiler. The thermal insulation of the chimney has to be done properly, it has to be absolutely gas-proof and smooth. On its lower part there has to be built in the opening for cleaning with the door. An brick-layed chimney has to have three layers with an insulation of 30 mm in the middle, if the chimney is built inside the house (i.e. inside the heated area), or an insulation of 50 mm if it is built outside the house (i.e. outside the heated area). The flue gas temperature has to be at least 30°C higher than the temperature of their condensation point. The choice and the construction of the chimney has to be performed by the authorized person. Inner diameter of the chimney must be selected according the possible effective chimney height and boiler power and according diagram below. The chimney must be dimensioned according to the "chimney selection diagram" with a minimum inner clear cross-section of the connection between the boiler and the chimney of Φ 130 mm for PelTec II Lambda 12/18/24, Φ 150 mm for PelTec II Lambda 36/48. The diagram was made for a chimney length of 2 m with two 90° elbows (bends). If the chimney does not fit into the specified frame, the chimney must be raised according to the guidelines in the note below the diagram. Connection flue gas tube can be mounted horizontally or at any angle which allows to gas, on his way to chimney, a constant increase of height with considering of exit point from fan. Connection flue gas tube must have openings for cleaning through which is possible to clean entire length of flue gas tube or must ensure easy removal part of flue gas tube which allow complete cleaning of connection flue gas tube. To prevent entry of condensate form chimney into the boiler, flue gas tube must be mounted 10 mm deeper into the chimney. **Connection flue gas tube between fan and chimney must be insulated with 30-50 mm mineral wool.**



The chimney must be resistant against flue condensate!

Diagram. Dimensioning of the chimney for PelTec II Lambda 12-48 kW

**Chimney dimensioning examples:
PelTec II Lambda 24**

Boiler heat output: **24 kW**
 Required usable chimney height: **7,5 m**
 Required inner chimney diameter: **130 mm**
 Inner diameter of the boiler-chimney connecting pipe: **130 mm**
 Fuel: **wood pellets**

Chimney dimensioning examples:
 (minimum inner clear cross-section of the connection between the boiler and the chimney)

10-50 kW

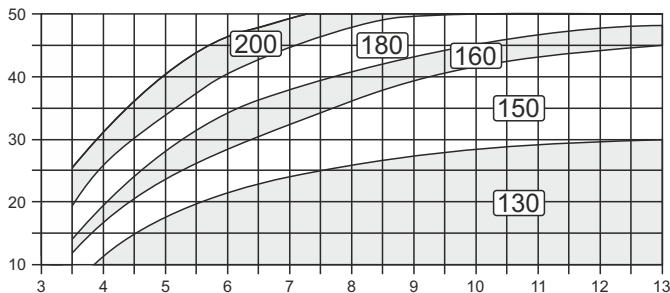

		boiler power (kW)				
		12	18	24	36	48
inner chimney diameter (mm)	130	4,5	5,5	7,5	-	-
	150	4	4,5	5,5	8	-
	160	3,5	4	5	6,5	-
	180	-	3,5	4	5,5	8,5
	200	-	-	-	4,5	7
	220	-	-	-	-	-
	250	-	-	-	-	-
		min. chimney effective height (m)				

NOTES:

For flue gas tubes up to 2 m and 2 flue gas elbows look at the diagram.
 In case of longer flue gas tube or there is more than 2 flue gas elbows, effective height must be selected from the diagram and for every additional meter of the flue gas tube and/or every additional flue gas elbow, add following value to the effective height:
 - PelTec II Lambda 12-18: +0,5 m
 - PelTec II Lambda 24-48: +1,0 m
 In case of flue gas tubes longer than 5 meters, recommended is (or it's necessary) select flue gas tube for 10 mm bigger than boiler output because of ash deposits during the boiler working.
 In any case, necessary is to predict correct amount cleaning openings for flue gas tube and elbows cleaning.

3.1. INSTALLATION OF THE CONNECTION FLUE GAS TUBE (BETWEEN FAN AND CHIMNEY) THERMAL INSULATION

EXAMPLE 1

a) $A \leq 1200$

b) $A > 1200$

1.

2.

3. max. 160 mm
(15 x)

EXAMPLE 2

1200 mm

B or D

C

1/2

1/2

D or B

1.

2.

3. (15 x)
max. 160 mm

4.0. INSTALLATION

All local regulations, including those referring to national and European standards need to be complied with when installing the appliance.

4.1. CONNECTION TO CENTRAL HEATING SYSTEM

All installation work must be made in accordance with valid national and European standards. Boiler **PelTec II Lambda** can be built in closed and open central heating systems. In both cases boiler can be fired with wood pellets. Installation has to be made, in according to technical standards, by a professional who will be responsible for proper boiler operation. Before connecting boiler to central heating system, the system has to be flushed to remove impurities remaining after system installation. It prevents boiler overheating, noise within the system, disturbances at a pump and mixing valve. Boiler should always be connected to central heating system by connectors, never by welding. Figure 2. shows safe distances required for boiler cleaning and maintenance.

4.1.1. CONNECTION TO OPEN HEATING SYSTEM

In open system it is necessary to put an open expansion vessel min. 0,5 m above the height of the highest heating body. If expansion vessel is located in a room without heating, it should be insulated.

4.1.2. CONNECTION TO CLOSED HEATING SYSTEM

In closed heating system it is **obligatory** to build in certified safety valve with opening pressure of 2,5 bar and a membrane expansion vessel. Safety valve and expansion vessel must be built in accordance with professional rules and between safety valve and expansion vessel and boiler must not be any valve. Schemes for possible configurations are on following pages.

Figure 3. Connections to connect the boiler to a closed heating system

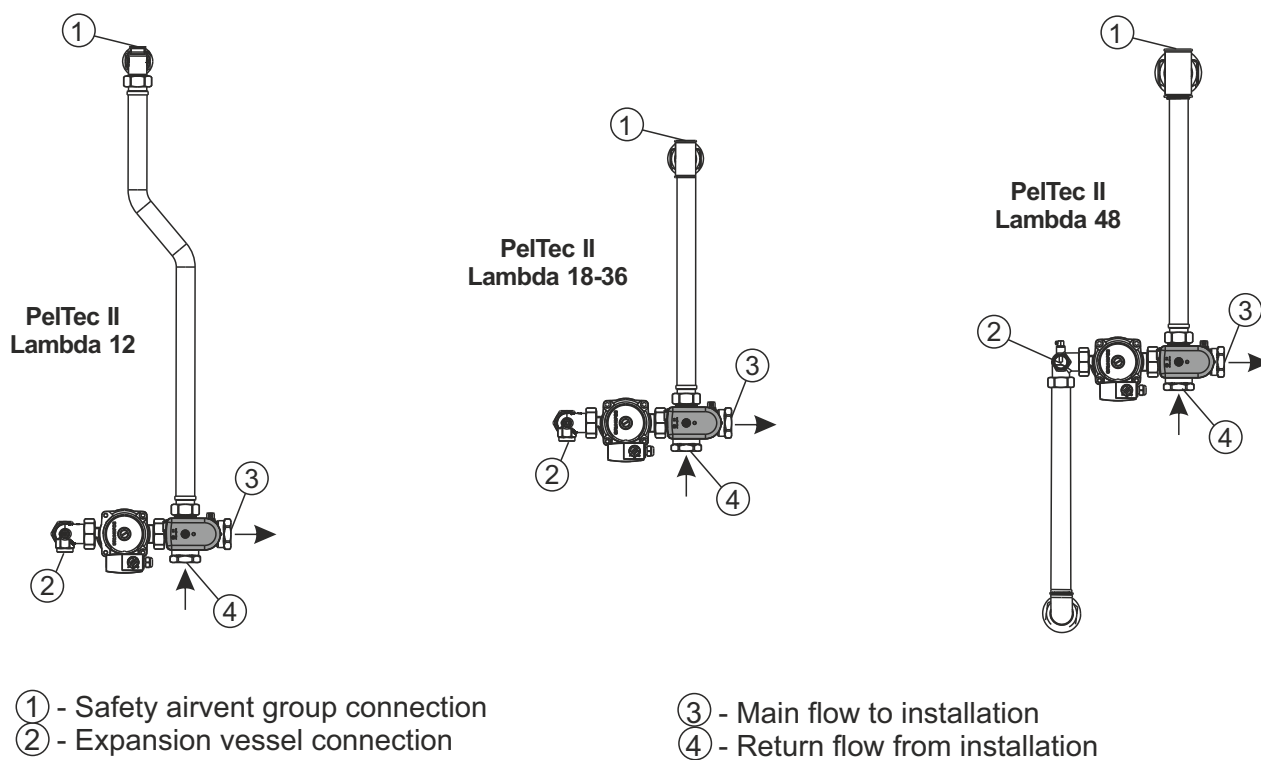

4.2. CONFIGURATION - DESCRIPTION

Temperatures choice depends on the configuration of heating. Below are shown all types of installation and configuration.

Pump group
(direct heating system pump / DHW)



Pump group
(heating system pump with 3-way valve with actuator)



Pump groups
(direct heating system pump / DHW and heating system pump with 3-way valve with actuator)

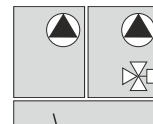

Manifold



MIXING VALVE

(4-way mixing valve with actuator - boiler circuit)

P(PWM) - (Boiler circuit)
(boiler pump)
is located in the boiler

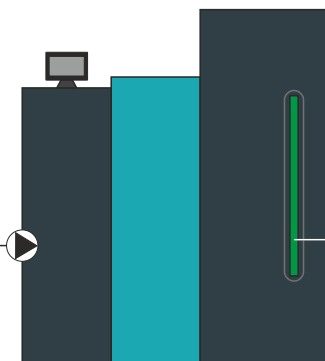

Fuel level sensor

4.2.1. EXAMPLE OF SENSORS AND PUMPS CONNECTIONS (CONFIGURATION 1)

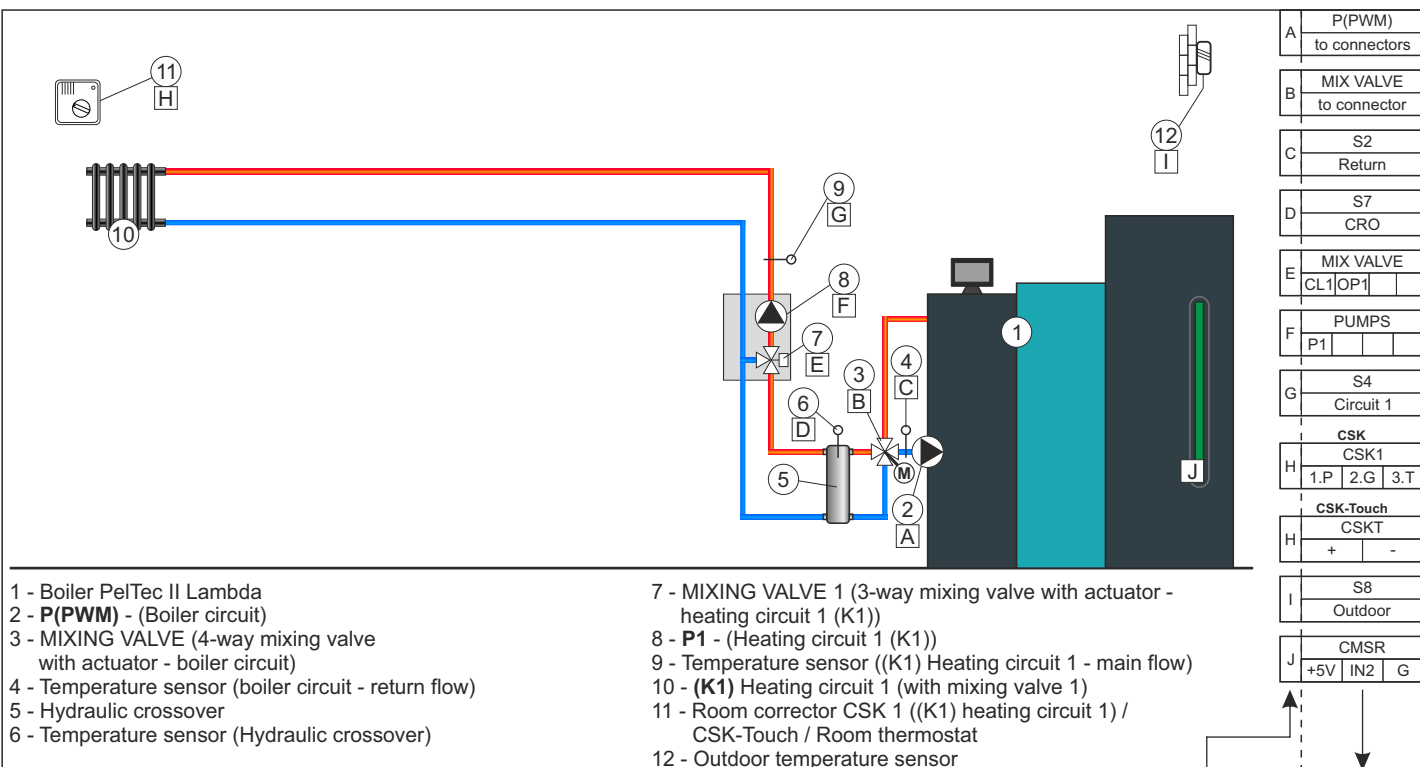

- 1 - Boiler PelTec II Lambda
- 2 - **P(PWM)** - (Boiler circuit)
- 3 - MIXING VALVE (4-way mixing valve with actuator - boiler circuit)
- 4 - Temperature sensor (boiler circuit - return flow)
- 5 - Hydraulic crossover
- 6 - Temperature sensor (Hydraulic crossover)
- 7 - MIXING VALVE 1 (3-way mixing valve with actuator - heating circuit 1 (K1))
- 8 - **P1** - (Heating circuit 1 (K1))
- 9 - Temperature sensor ((K1) Heating circuit 1 - main flow)
- 10 - **(K1)** Heating circuit 1 (with mixing valve 1)
- 11 - Room corrector CSK 1 ((K1) heating circuit 1) / CSK-Touch / Room thermostat
- 12 - Outdoor temperature sensor

Notes:
 - in this configuration is possible to upgrade up to 3 unit "CM2K module for regulation 2 heating circuits".
 - the first CSK-Touch can be connected to the boiler wired or wirelessly, the second CSK-Touch can only be connected wirelessly.

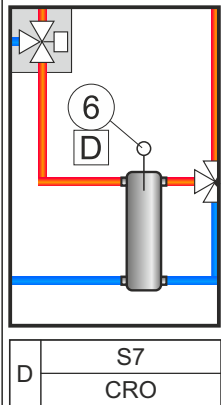

Example of the position of CRO on the main PCB UniDrive.



Main PCB: UniDrive



Devices (pumps, CSK, etc.)
 Marks on the UniDrive main PCB.

4.2.2. CONFIGURATION / SCHEME

CONFIGURATION 1

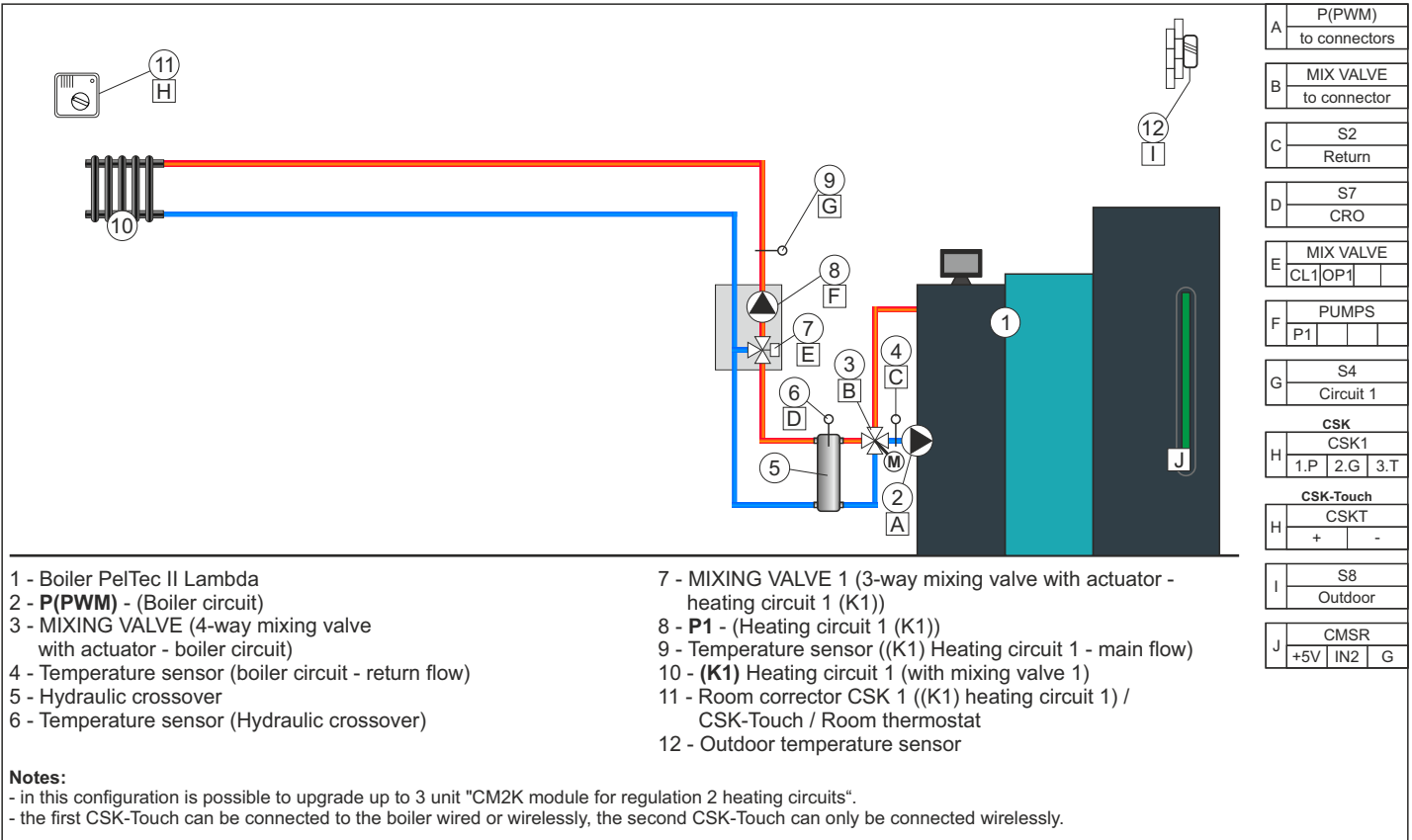

CONFIGURATION 2

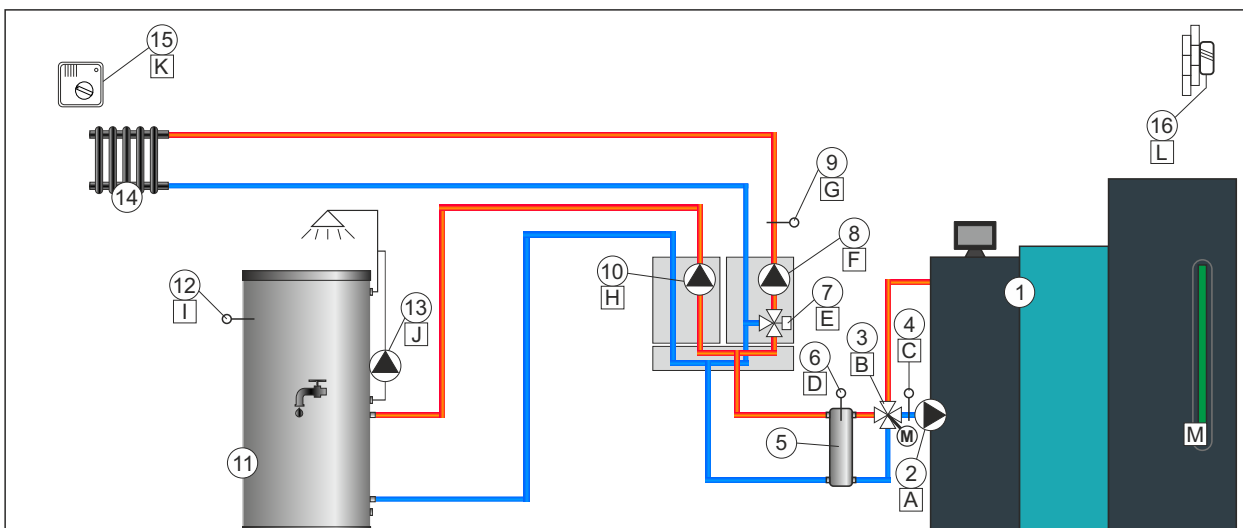

- 1 - Boiler PelTec II Lambda
- 2 - P(PWM) - (Boiler circuit)
- 3 - MIXING VALVE (4-way mixing valve with actuator - boiler circuit)
- 4 - Temperature sensor (boiler circuit - return flow)
- 5 - Hydraulic crossover
- 6 - Temperature sensor (Hydraulic crossover)
- 7 - MIXING VALVE 1 (3-way mixing valve with actuator - heating circuit 1 (K1))
- 8 - P1 - (Heating circuit 1 (K1))

- 9 - Temperature sensor ((K1) Heating circuit 1 - main flow)
- 10 - P2 - DHW (Heating circuit 2 (K2))
- 11 - (K2) Heating circuit 2 (DHW)
- 12 - Temperature sensor DHW ((K2) Heating circuit 2)
- 13 - P3 - Recirculation DHW (Heating circuit 2 (K2))
- 14 - (K1) Heating circuit 1 (with mixing valve 1)
- 15 - Room corrector CSK 1 ((K1) heating circuit 1) / CSK-Touch / Room thermostat
- 16 - Outdoor temperature sensor

Notes:

- in this configuration is possible to upgrade up to 3 unit "CM2K module for regulation 2 heating circuits".
- the first CSK-Touch can be connected to the boiler wired or wirelessly, the second CSK-Touch can only be connected wirelessly.
- in this configuration, it is not possible to use Rotary valve or Screw refill (additional equipment).

A	P(PWM) to connectors
B	MIX VALVE to connector
C	S2 Return
D	S7 CRO
E	MIX VALVE CL1 OP1
F	PUMPS P1
G	S4 Circuit 1
H	PUMPS P2
I	S6 Circuit 2
J	PUMPS P3
CSK	
K	CSK1 1.P 2.G 3.T
CSK-Touch	
K	CSKT + -
L	S8 Outdoor
M	CMSR +5V IN2 G

CONFIGURATION 3

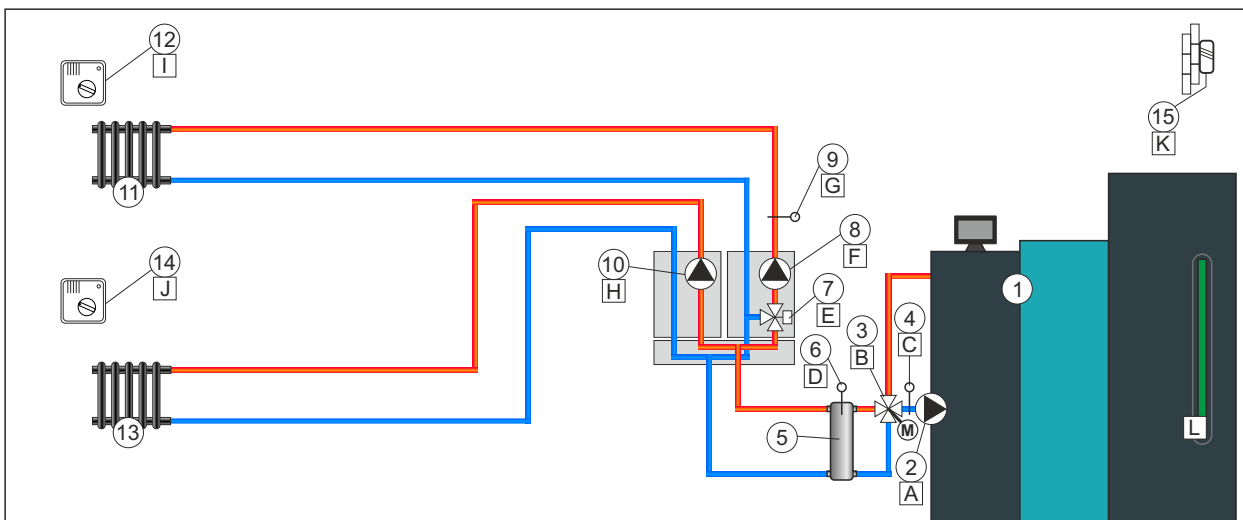

- 1 - Boiler PelTec II Lambda
- 2 - P(PWM) - (Boiler circuit)
- 3 - MIXING VALVE (4-way mixing valve with actuator - boiler circuit)
- 4 - Temperature sensor (boiler circuit - return flow)
- 5 - Hydraulic crossover
- 6 - Temperature sensor (Hydraulic crossover)
- 7 - MIXING VALVE 1 (3-way mixing valve with actuator - heating circuit 1 (K1))
- 8 - P1 - (Heating circuit 1 (K1))

- 9 - Temperature sensor ((K1) Heating circuit 1 - main flow)
- 10 - P2 - (heating circuit 2 (K2))
- 11 - (K1) Heating circuit 1 (with mixing valve 1)
- 12 - Room corrector CSK 1 ((K1) heating circuit 1) / CSK-Touch / Room thermostat
- 13 - (K2) Heating circuit 2 - (direct circuit)
- 14 - Room corrector CSK 2 ((K2) heating circuit 2) / CSK-Touch / Room thermostat
- 15 - Outdoor temperature sensor

Notes:

- in this configuration is possible to connect up to 3 unit "CM2K module for regulation 2 heating circuits".
- the first CSK-Touch can be connected to the boiler wired or wirelessly, the second CSK-Touch can only be connected wirelessly.

A	P(PWM) to connectors
B	MIX VALVE to connector
C	S2 Return
D	S7 CRO
E	MIX VALVE CL1 OP1
F	PUMPS P1
G	S4 Circuit 1
H	PUMPS P2
CSK 1	
I	CSK1 1.P 2.G 3.T
CSK-Touch 1	
I	CSKT + -
CSK 2	
J	CSK2 1.P 2.G 3.T
K	S8 Outdoor
L	CMSR +5V IN2 G

CONFIGURATION 4

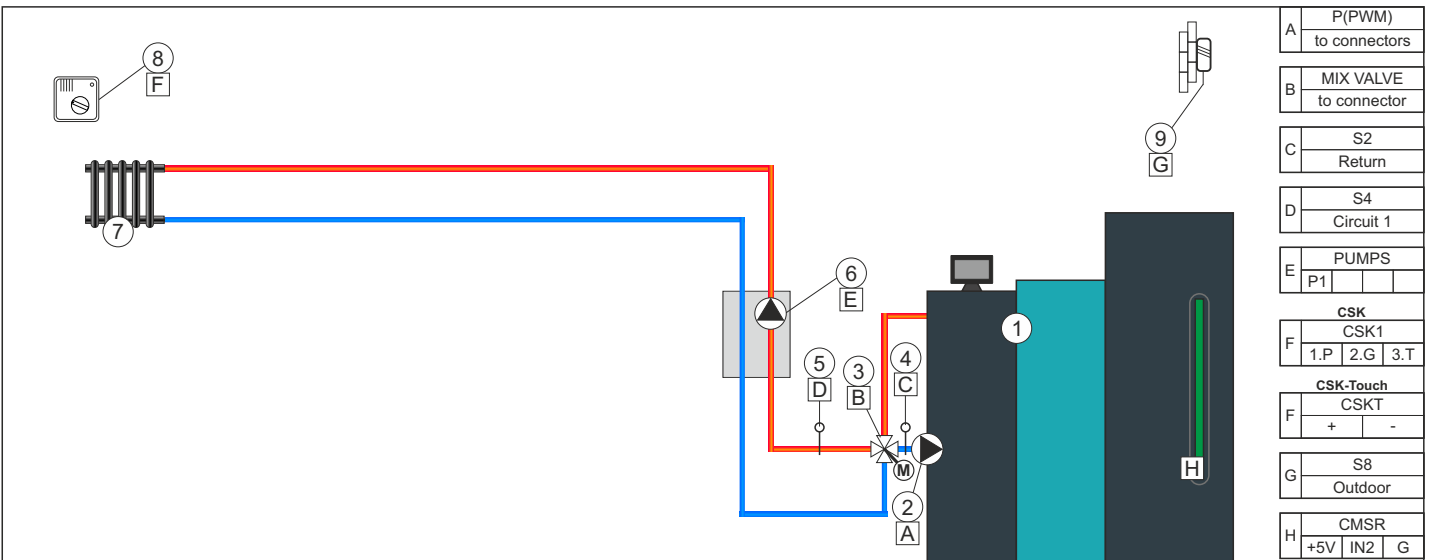

- 1 - Boiler PelTec II Lambda
- 2 - P(PWM) - (Boiler circuit)
- 3 - MIXING VALVE (4-way mixing valve with actuator - boiler circuit)
- 4 - Temperature sensor (boiler circuit - return flow)
- 5 - Temperature sensor ((K1) Heating circuit 1 - main flow)
- 6 - P1 - (Heating circuit 1 (K1))
- 7 - (K1) Heating circuit 1 - (direct circuit)
- 8 - Room corrector CSK 1 ((K1) heating circuit 1) / CSK-Touch / Room thermostat
- 9 - Outdoor temperature sensor

Notes:

- in this configuration, it is not possible to connect the "CM2K module for regulation 2 heating circuits".
- the first CSK-Touch can be connected to the boiler wired or wirelessly, the second CSK-Touch can only be connected wirelessly.

CONFIGURATION 5

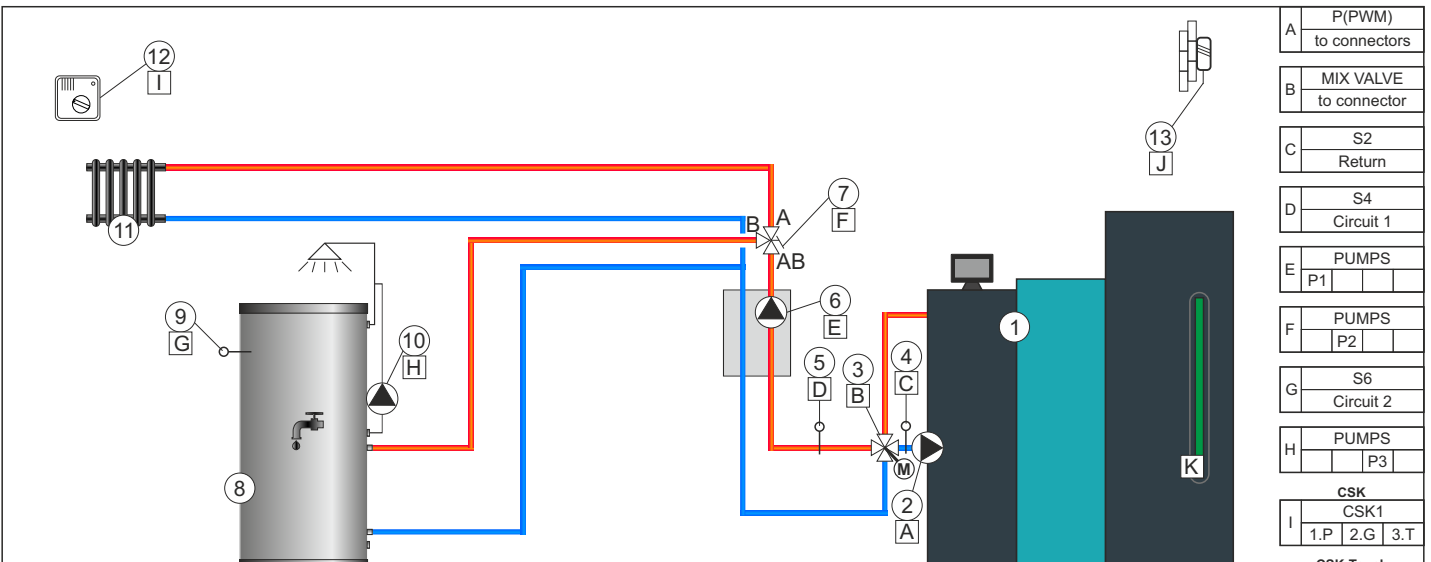

- 1 - Boiler PelTec II Lambda
- 2 - P(PWM) - (Boiler circuit)
- 3 - MIXING VALVE (4-way mixing valve with actuator - boiler circuit)
- 4 - Temperature sensor (boiler circuit - return flow)
- 5 - Temperature sensor ((K1) Heating circuit 1 - main flow)
- 6 - P1 - P1
- 7 - P2 - Diverting valve
- 8 - (K2) Heating circuit 2 (DHW)
- 9 - Temperature sensor DHW ((K2) Heating circuit 2)
- 10 - P3 - Recirculation DHW (Heating circuit 2 (K2))
- 11 - (K1) Heating circuit 1 - (direct circuit)
- 12 - Room corrector CSK 1 ((K1) heating circuit 1) / CSK-Touch / Room thermostat
- 13 - Outdoor temperature sensor

Notes:

- in this configuration, it is not possible to connect the "CM2K module for regulation 2 heating circuits".
- the first CSK-Touch can be connected to the boiler wired or wirelessly, the second CSK-Touch can only be connected wirelessly.
- in this configuration, it is not possible to use Rotary valve or Screw refill (additional equipment).

CONFIGURATION 6

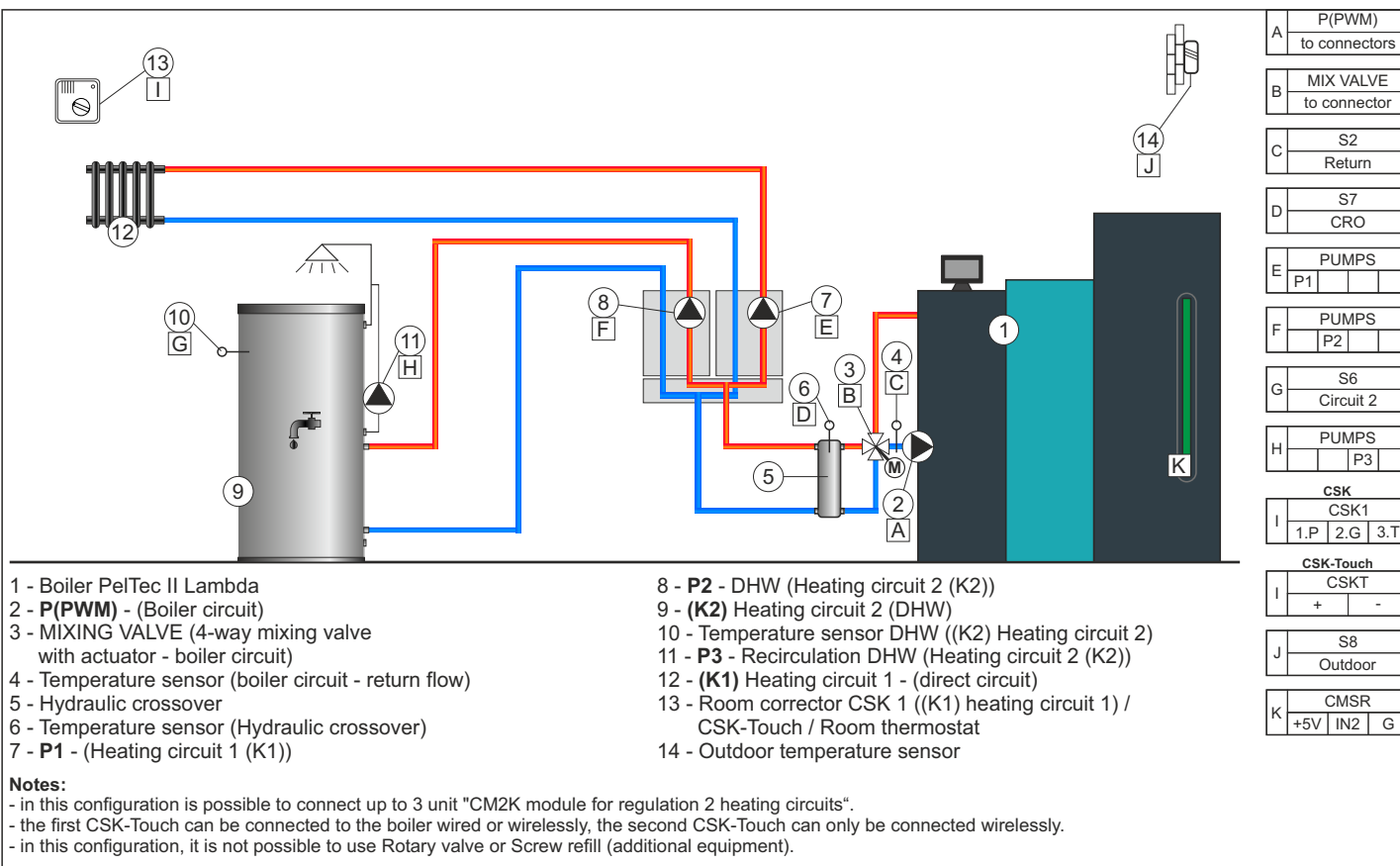

CONFIGURATION 7

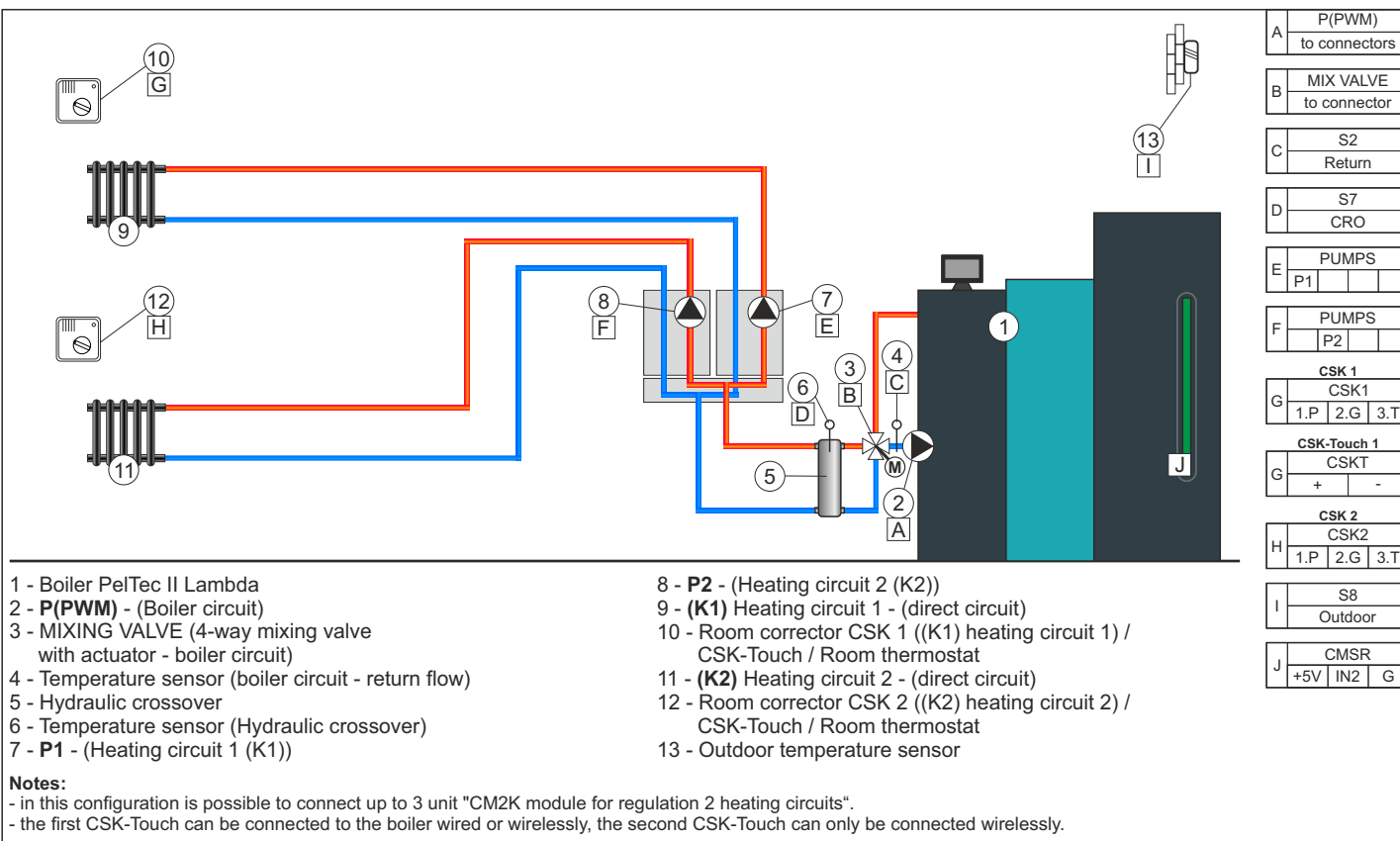

CONFIGURATION 8

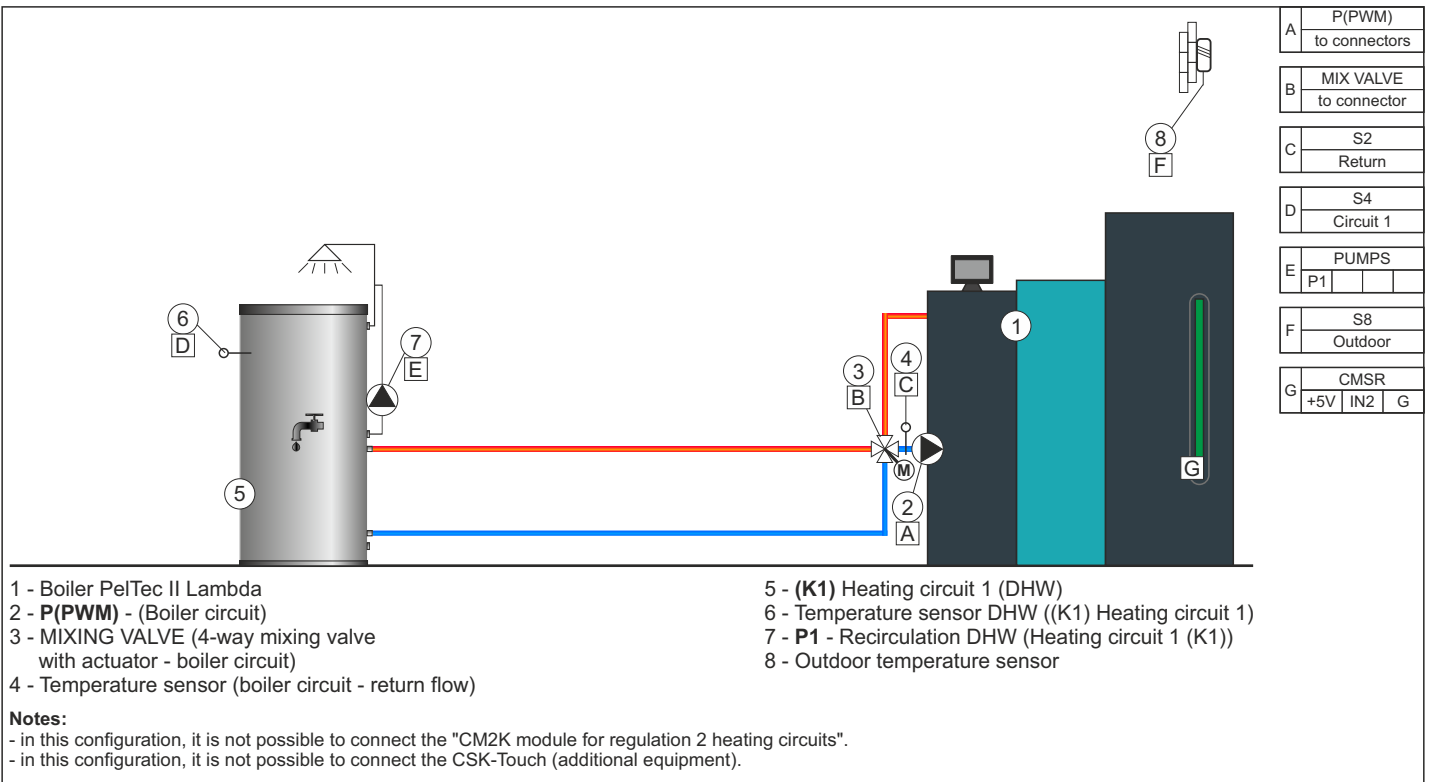

CONFIGURATION 9

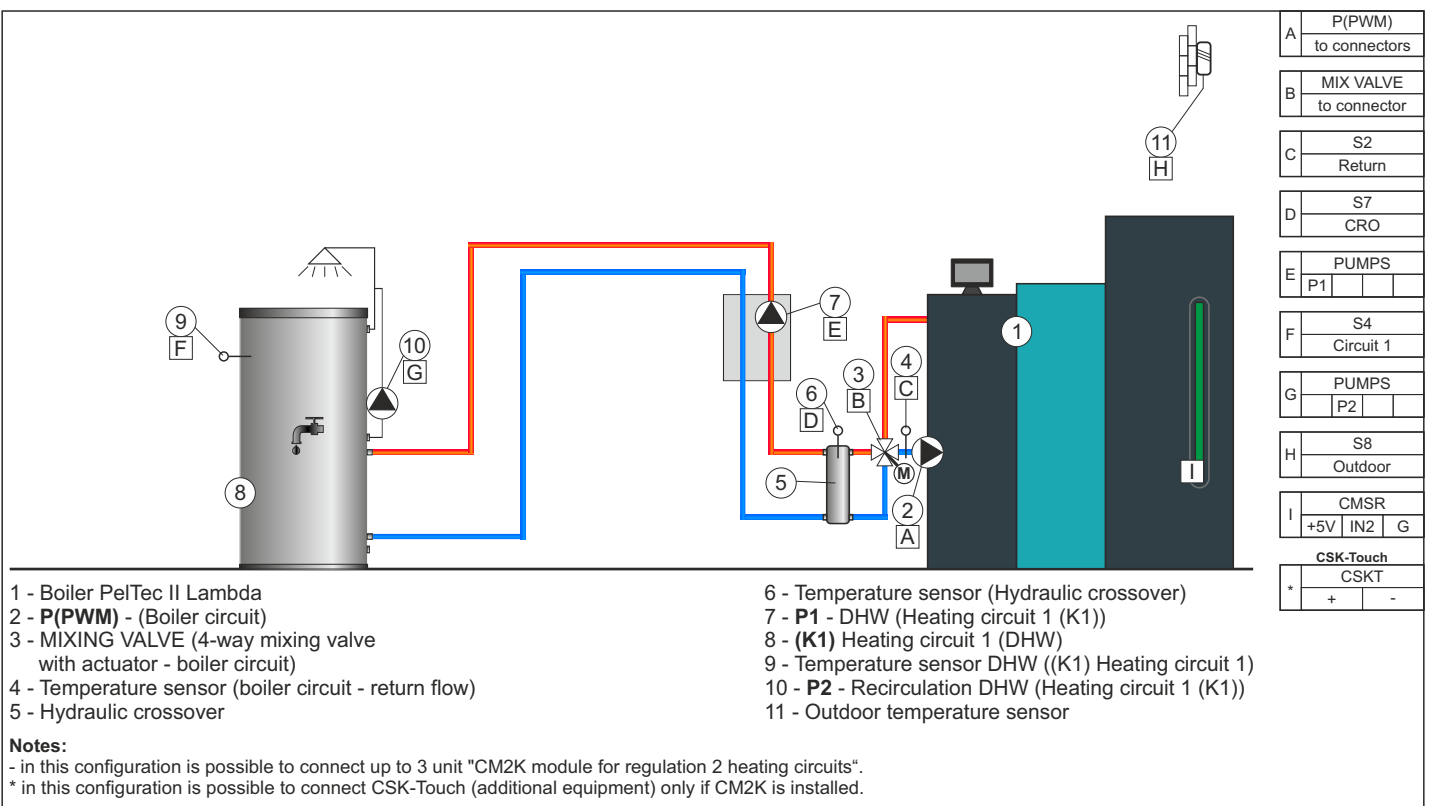

CONFIGURATION 10

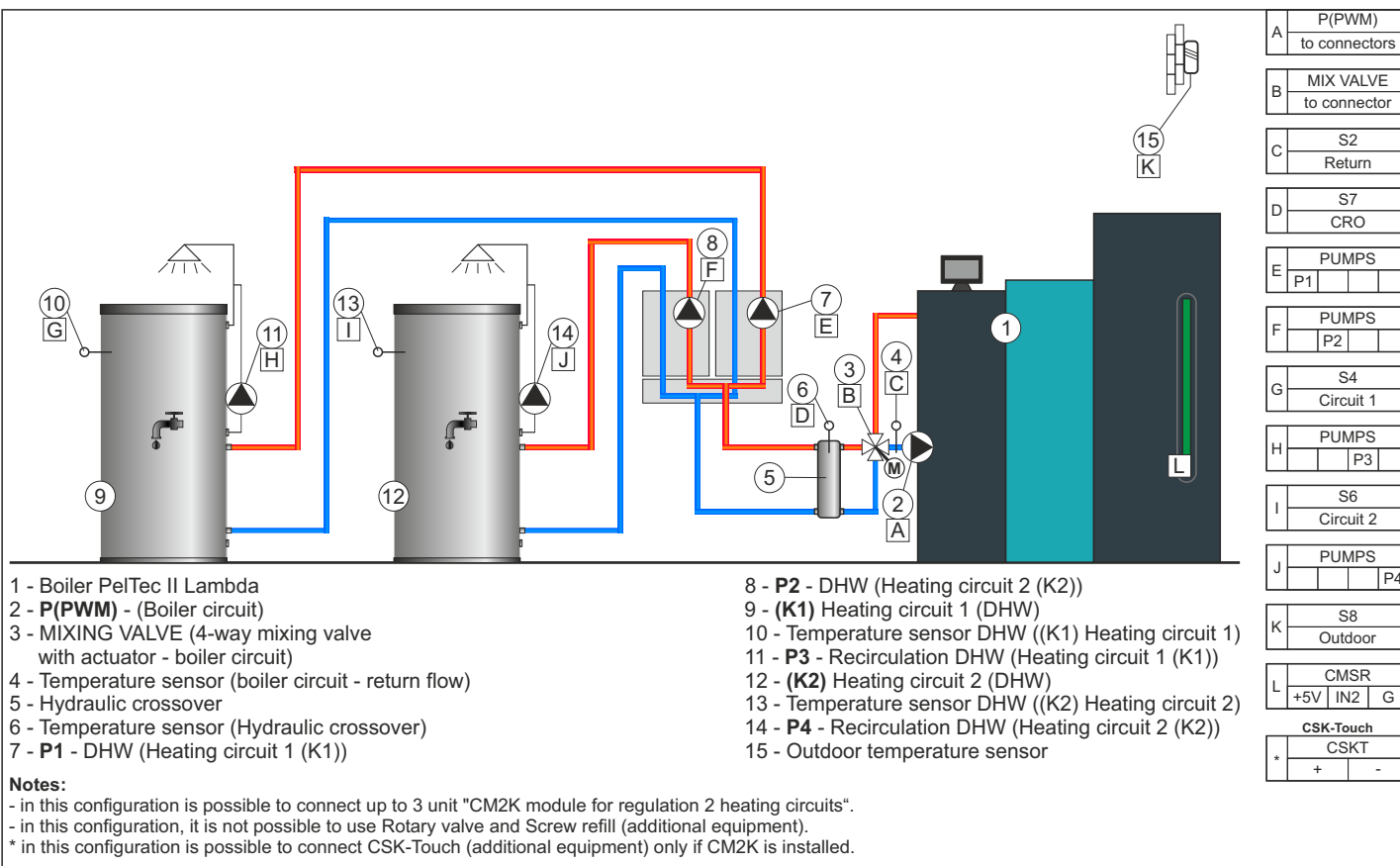

CONFIGURATION 11

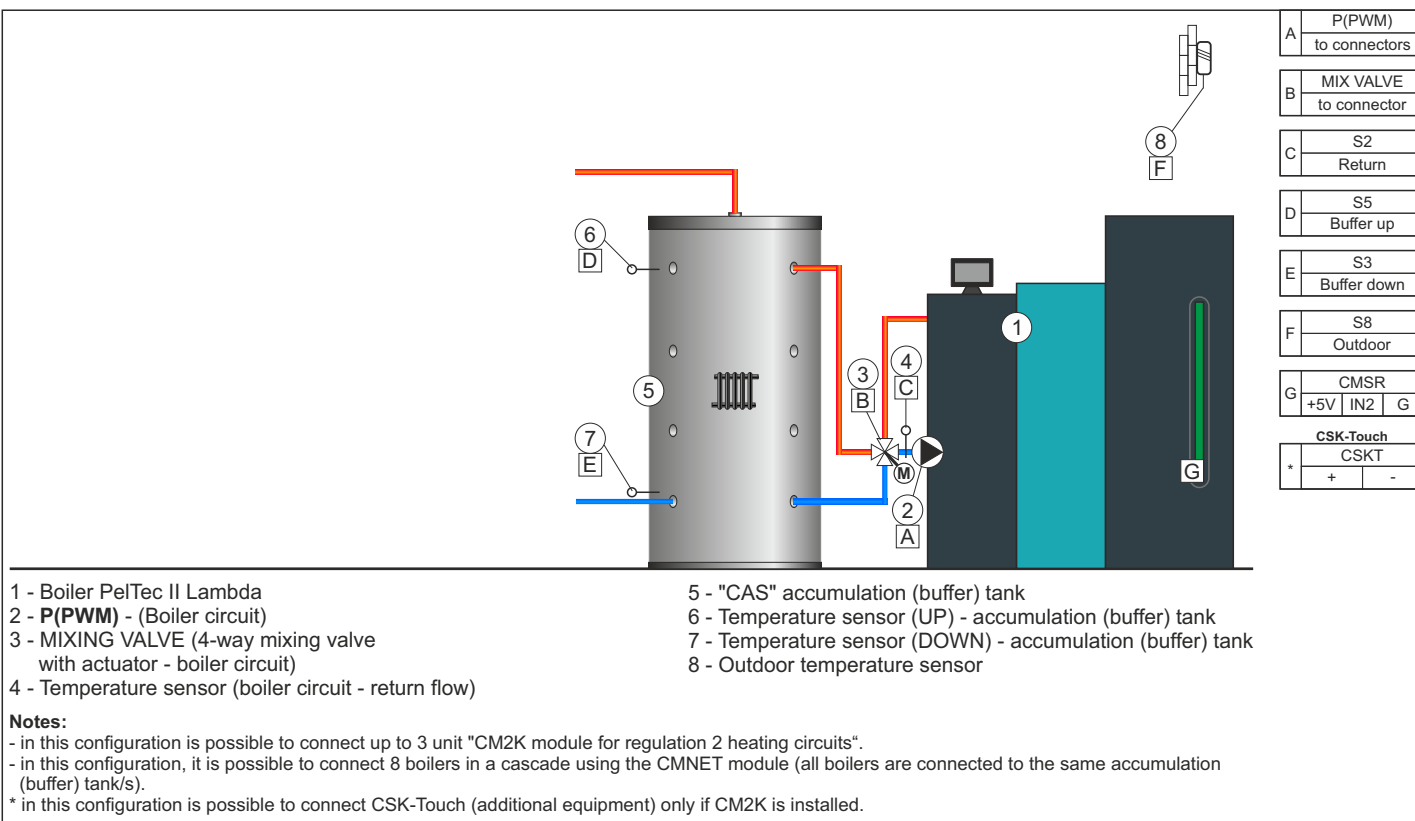

CONFIGURATION 12

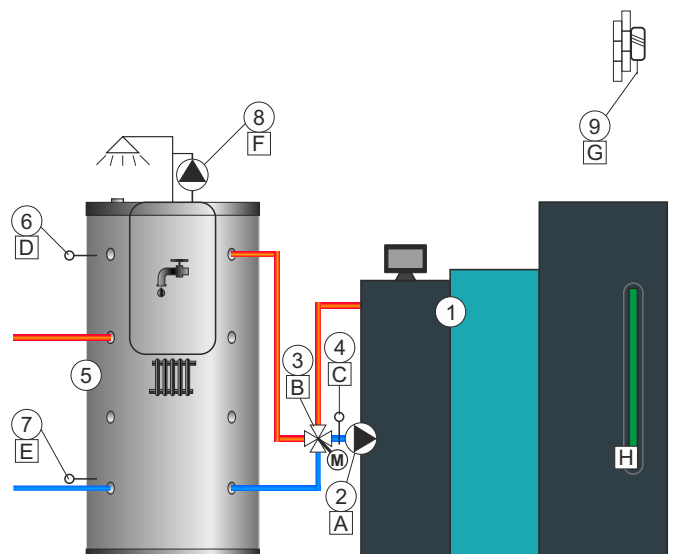

A	P(PWM) to connectors
B	MIX VALVE to connector
C	S2 Return
D	S5 Buffer up
E	S3 Buffer down
F	PUMPS P1
G	S8 Outdoor
H	CMSR +5V IN2 G
CSK-Touch	
*	CSKT + -

- 1 - Boiler PelTec II Lambda
- 2 - P(PWM) - (Boiler circuit)
- 3 - MIXING VALVE (4-way mixing valve with actuator - boiler circuit)
- 4 - Temperature sensor (boiler circuit - return flow)
- 5 - "CAS-B" accumulation (buffer) tank
- 6 - Temperature sensor (UP) - accumulation (buffer) tank
- 7 - Temperature sensor (DOWN) - accumulation (buffer) tank
- 8 - P1 - Recirculation DHW
- 9 - Outdoor temperature sensor

Notes:

- in this configuration is possible to connect up to 3 unit "CM2K module for regulation 2 heating circuits".
- * in this configuration is possible to connect CSK-Touch (additional equipment) only if CM2K is installed.

CONFIGURATION 13

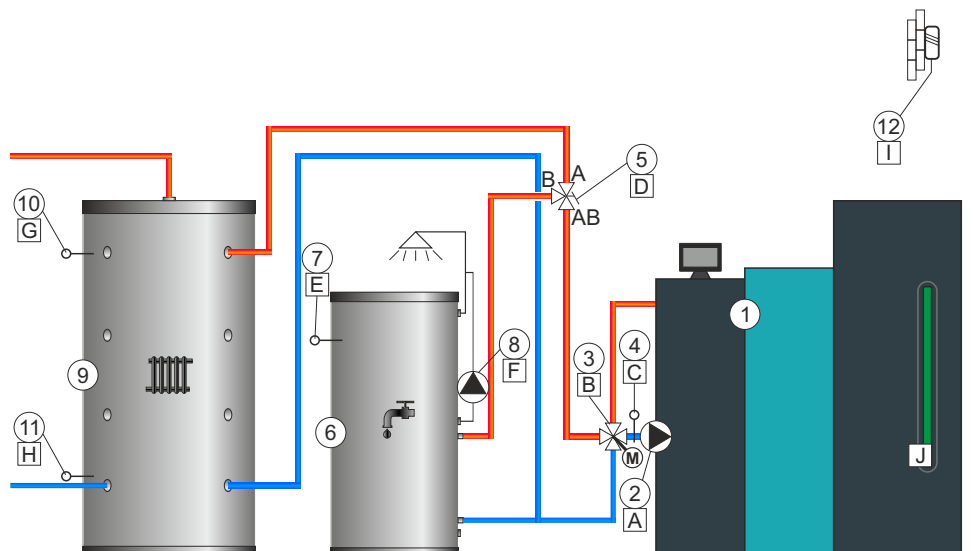

A	P(PWM) to connectors
B	MIX VALVE to connector
C	S2 Return
D	PUMPS P1
E	S4 Circuit 1
F	PUMPS P2
G	S5 Buffer up
H	S3 Buffer down
I	S8 Outdoor
J	CMSR +5V IN2 G
CSK-Touch	
*	CSKT + -

- 1 - Boiler PelTec II Lambda
- 2 - P(PWM) - (Boiler circuit)
- 3 - MIXING VALVE (4-way mixing valve with actuator - boiler circuit)
- 4 - Temperature sensor (boiler circuit - return flow)
- 5 - P1 - Diverting valve
- 6 - (K1) Heating circuit 1 (DHW)
- 7 - Temperature sensor DHW ((K1) Heating circuit 1)
- 8 - P2 - Recirculation DHW (Heating circuit 1 (K1))
- 9 - "CAS" accumulation (buffer) tank
- 10 - Temperature sensor (UP) - accumulation (buffer) tank
- 11 - Temperature sensor (DOWN) - accumulation (buffer) tank
- 12 - Outdoor temperature sensor

Notes:

- in this configuration is possible to connect up to 3 unit "CM2K module for regulation 2 heating circuits".
- * in this configuration is possible to connect CSK-Touch (additional equipment) only if CM2K is installed.

CONFIGURATION 14

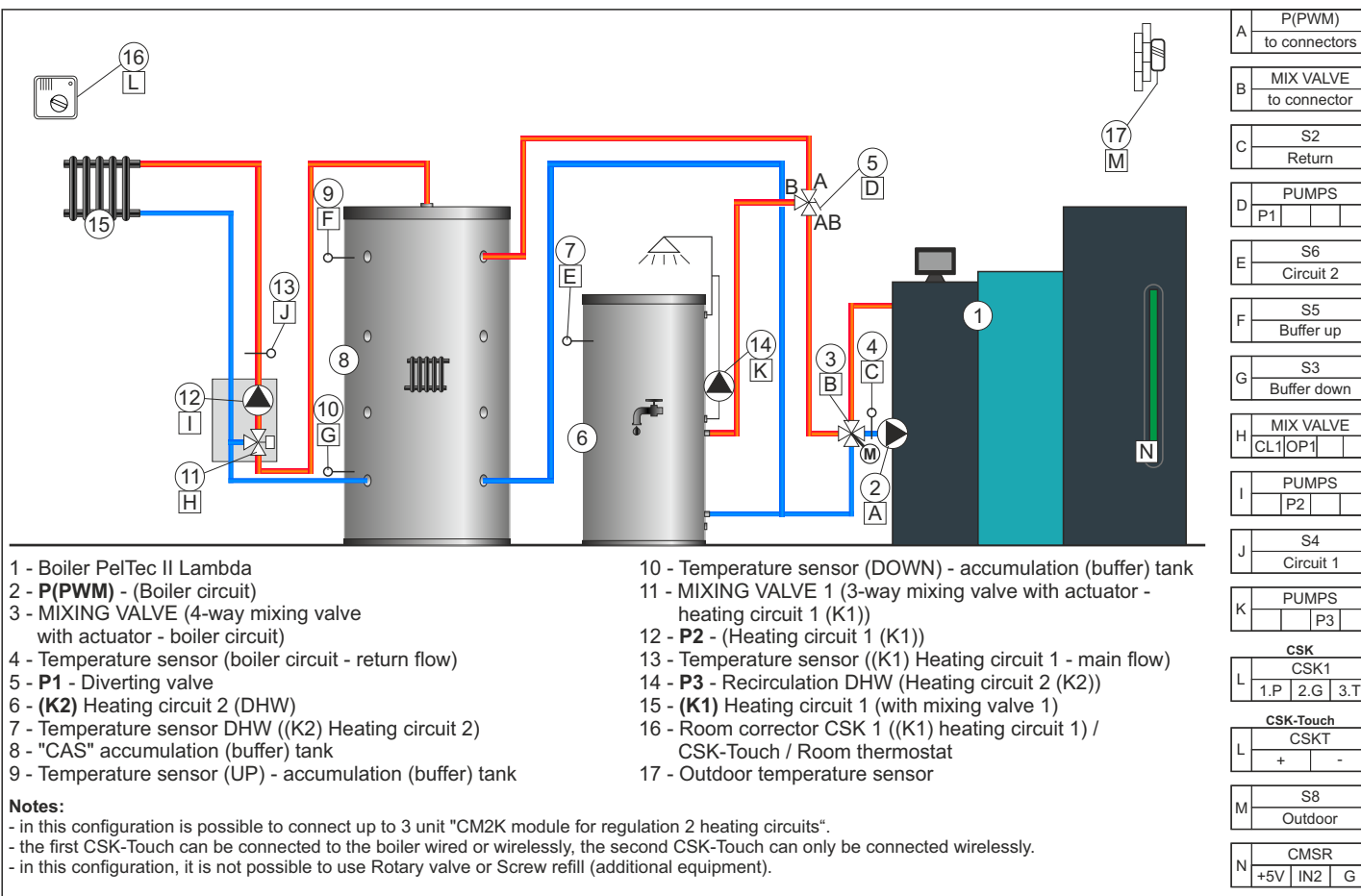

CONFIGURATION 15

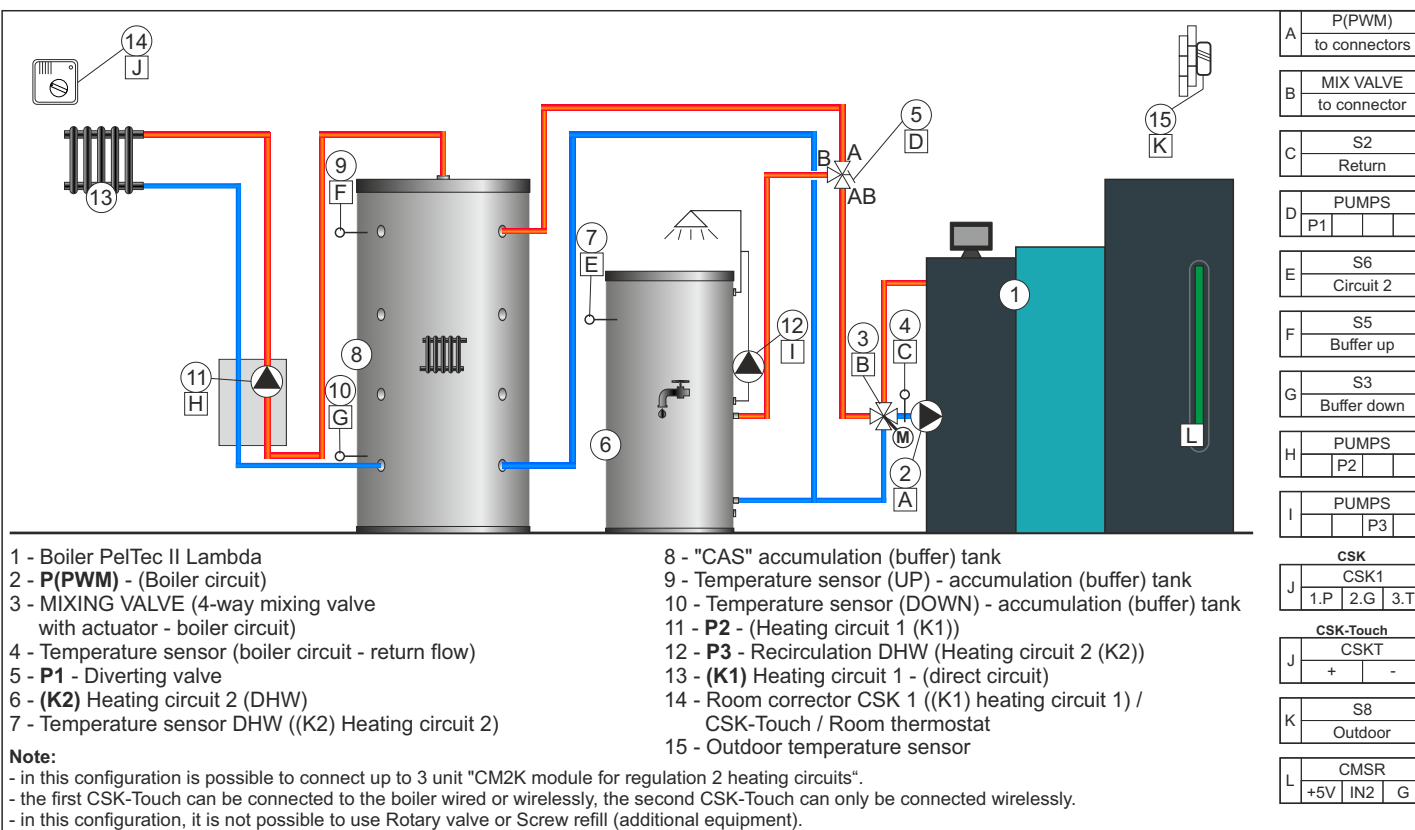

CONFIGURATION 16

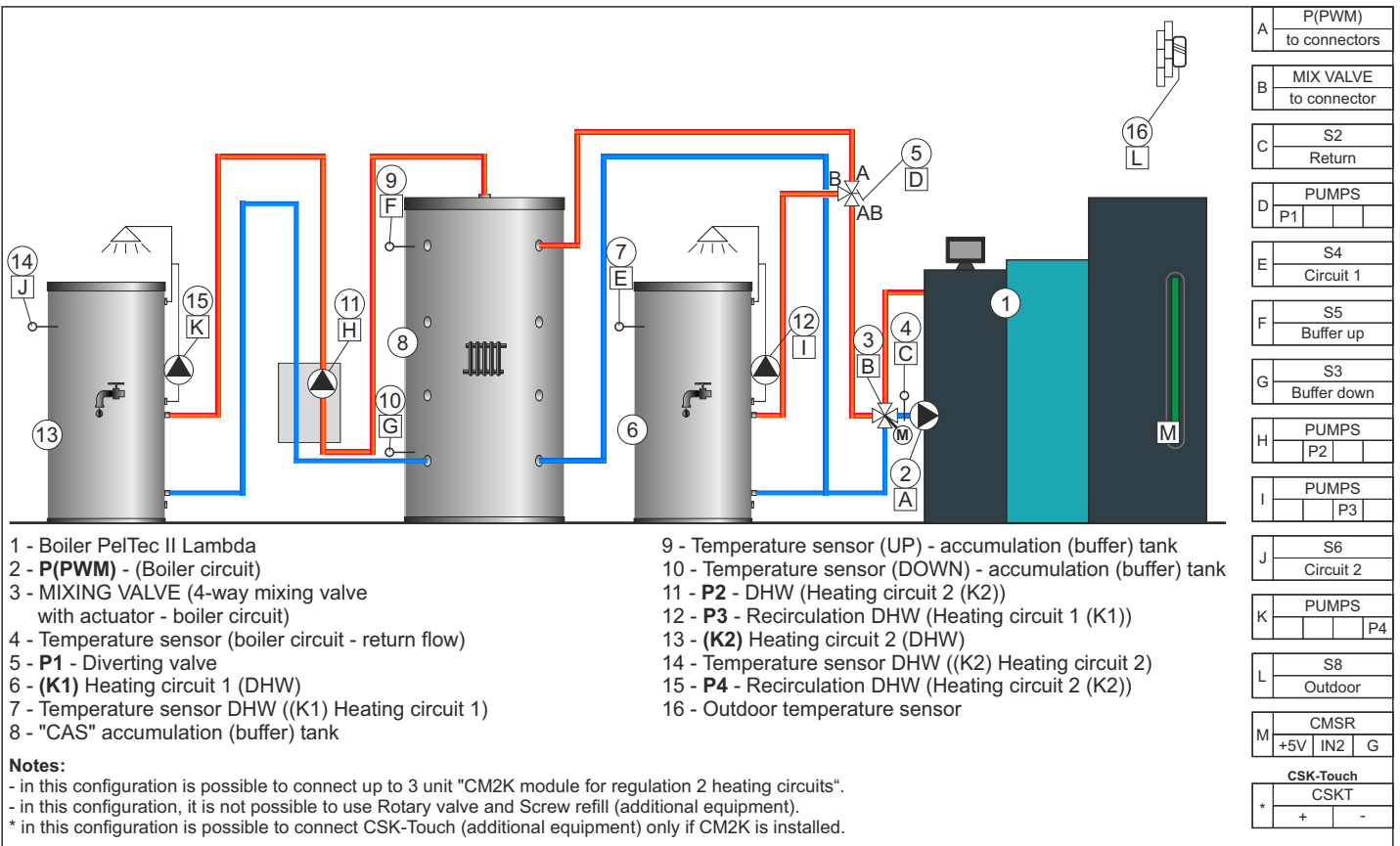

CONFIGURATION 17

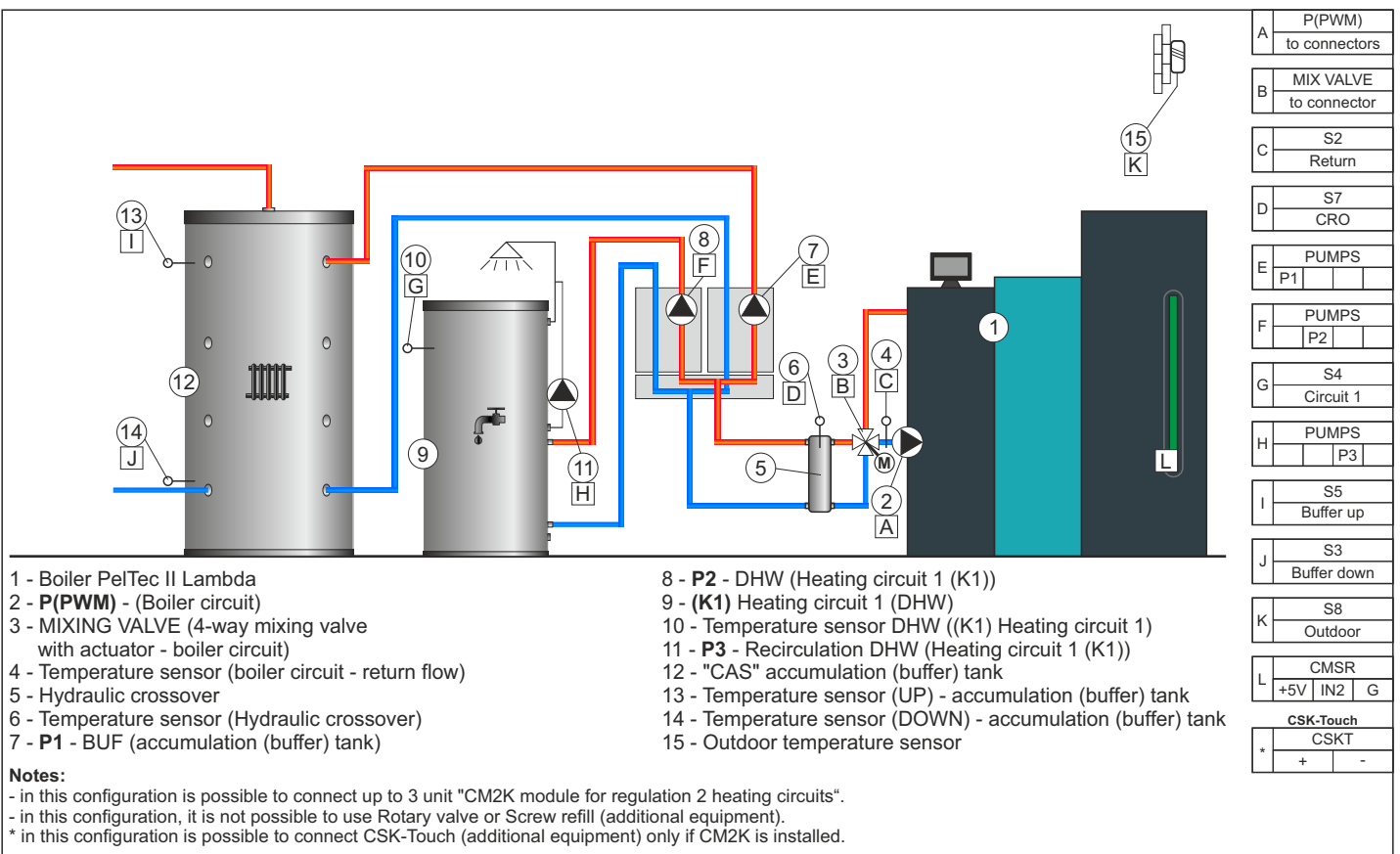

CONFIGURATION 18

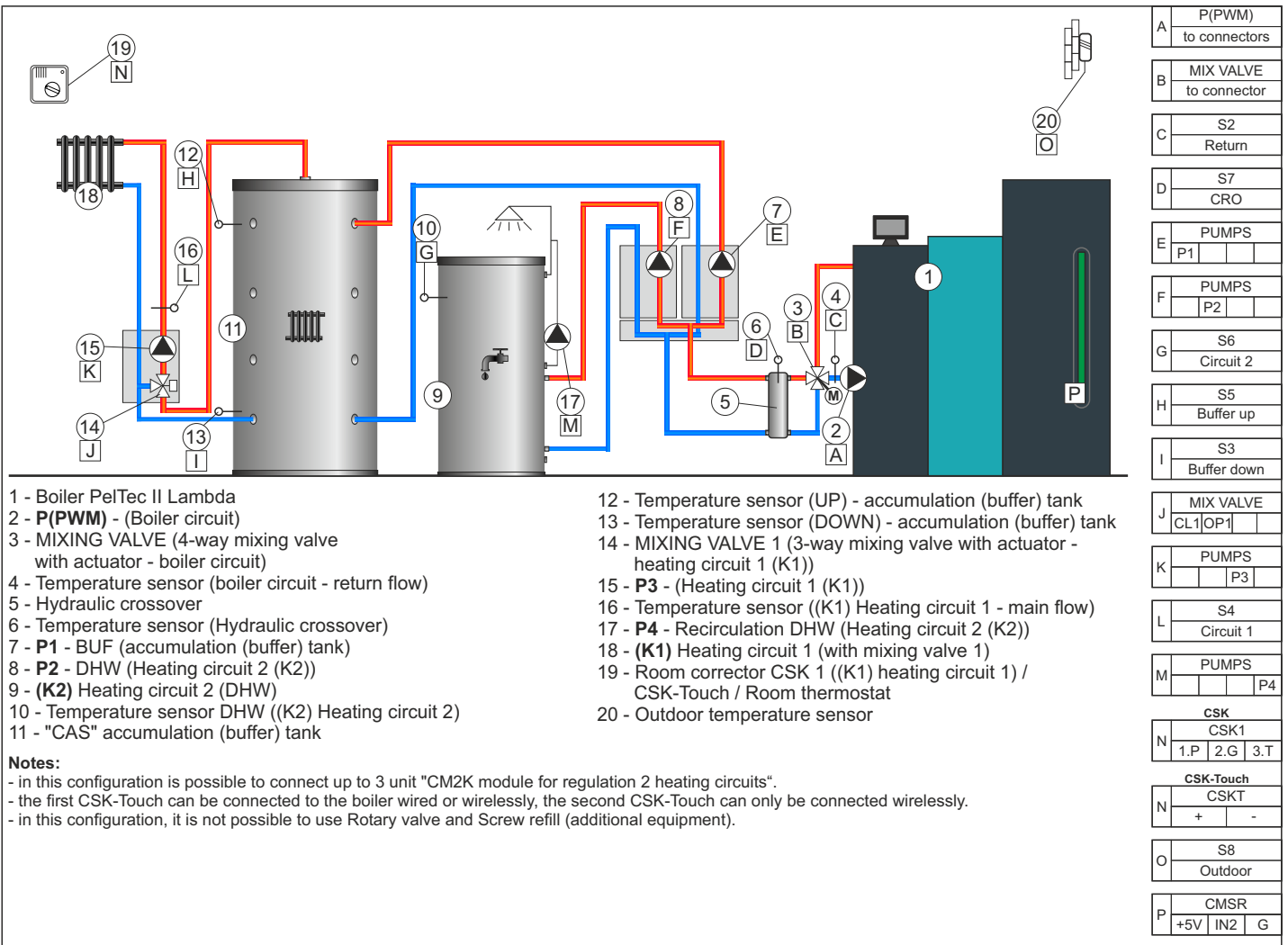

CONFIGURATION 19

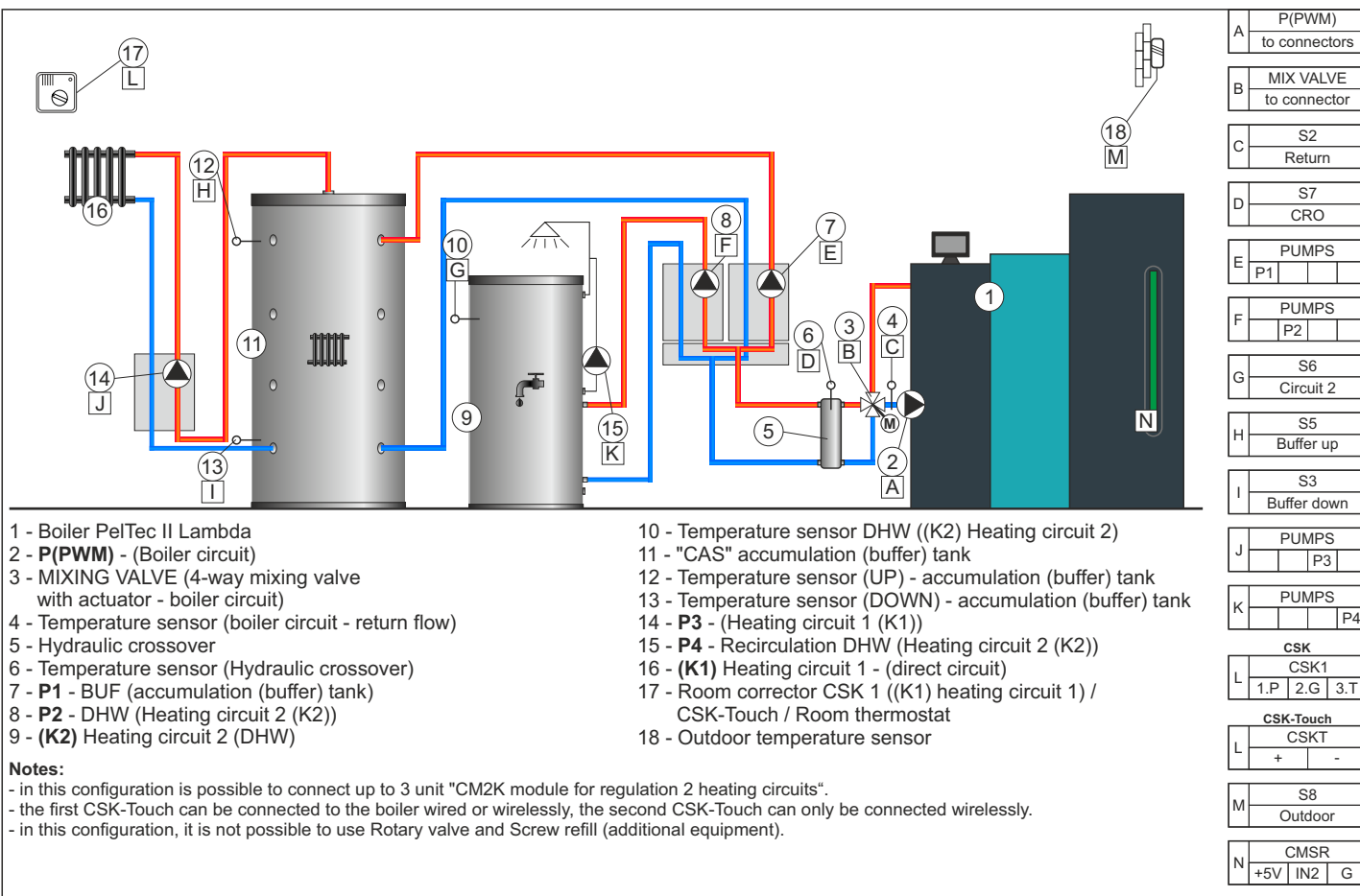

CONFIGURATION 20

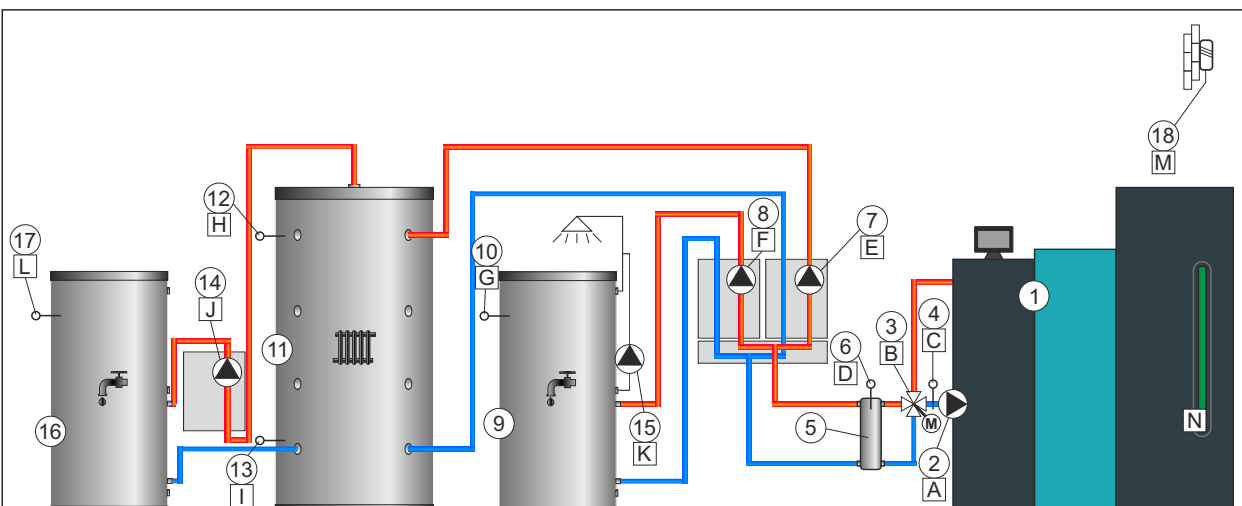

- 1 - Boiler PelTec II Lambda
- 2 - P(PWM) - (Boiler circuit)
- 3 - MIXING VALVE (4-way mixing valve with actuator - boiler circuit)
- 4 - Temperature sensor (boiler circuit - return flow)
- 5 - Hydraulic crossover
- 6 - Temperature sensor (Hydraulic crossover)
- 7 - P1 - BUF (accumulation (buffer) tank)
- 8 - P2 - DHW (Heating circuit 1 (K1))
- 9 - (K1) Heating circuit 1 (DHW)
- 10 - Temperature sensor DHW ((K1) Heating circuit 1)
- 11 - "CAS" accumulation (buffer) tank
- 12 - Temperature sensor (UP) - accumulation (buffer) tank
- 13 - Temperature sensor (DOWN) - accumulation (buffer) tank
- 14 - P3 - DHW (Heating circuit 2 (K2))
- 15 - P4 - Recirculation DHW (Heating circuit 1 (K1))
- 16 - (K2) Heating circuit 2 (DHW)
- 17 - Temperature sensor DHW ((K2) Heating circuit 2)
- 18 - Outdoor temperature sensor

Notes:

- in this configuration is possible to connect up to 3 unit "CM2K module for regulation 2 heating circuits".
- in this configuration, it is not possible to use Rotary valve and Screw refill (additional equipment).
- * in this configuration is possible to connect CSK-Touch (additional equipment) only if CM2K is installed.

A	P(PWM) to connectors
B	MIX VALVE to connector
C	S2 Return
D	S7 CRO
E	PUMPS P1
F	PUMPS P2
G	S4 Circuit 1
H	S5 Buffer up
I	S3 Buffer down
J	PUMPS P3
K	PUMPS P4
L	S6 Circuit 2
M	S8 Outdoor
N	CMSR +5V IN2 G
CSK-Touch	
*	CSKT + -

CONFIGURATION 21

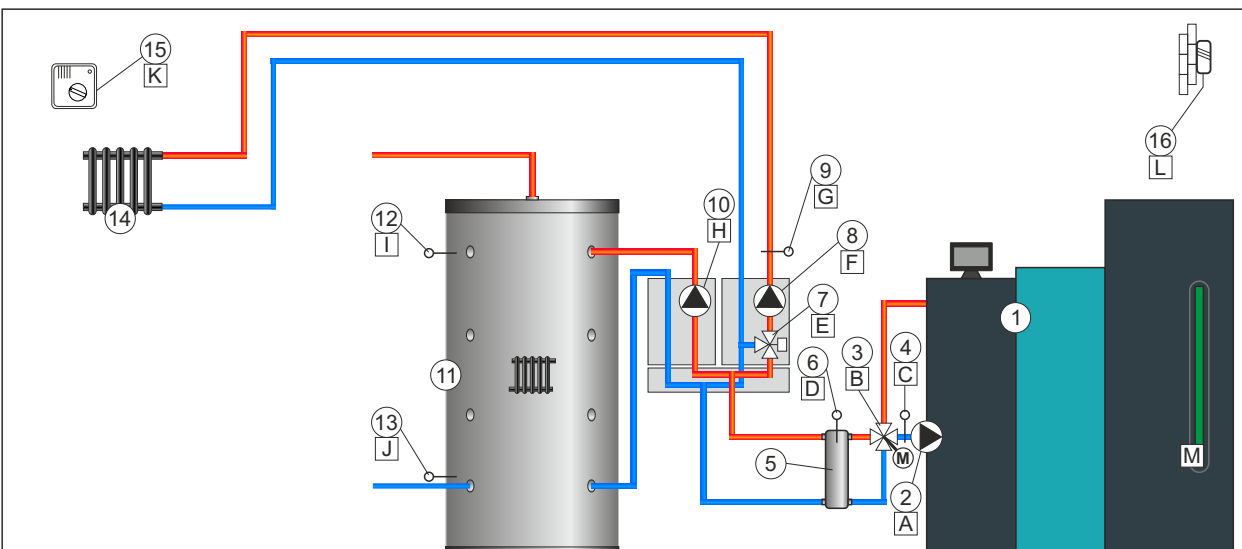

- 1 - Boiler PelTec II Lambda
- 2 - P(PWM) - (Boiler circuit)
- 3 - MIXING VALVE (4-way mixing valve with actuator - boiler circuit)
- 4 - Temperature sensor (boiler circuit - return flow)
- 5 - Hydraulic crossover
- 6 - Temperature sensor (Hydraulic crossover)
- 7 - MIXING VALVE 1 (3-way mixing valve with actuator - heating circuit 1 (K1))
- 8 - P1 - (Heating circuit 1 (K1))
- 9 - Temperature sensor ((K1) Heating circuit 1 - main flow)
- 10 - P2 - BUF (accumulation (buffer) tank)
- 11 - "CAS" accumulation (buffer) tank
- 12 - Temperature sensor (UP) - accumulation (buffer) tank
- 13 - Temperature sensor (DOWN) - accumulation (buffer) tank
- 14 - (K1) Heating circuit 1 (with mixing valve 1)
- 15 - Room corrector CSK 1 ((K1) heating circuit 1) / CSK-Touch / Room thermostat
- 16 - Outdoor temperature sensor

Notes:

- in this configuration is possible to connect up to 3 unit "CM2K module for regulation 2 heating circuits".
- the first CSK-Touch can be connected to the boiler wired or wirelessly, the second CSK-Touch can only be connected wirelessly.

A	P(PWM) to connectors
B	MIX VALVE to connector
C	S2 Return
D	S7 CRO
E	MIX VALVE CL1 OP1
F	PUMPS P1
G	S4 Circuit 1
H	PUMPS P2
I	S5 Buffer up
J	S3 Buffer down
CSK	
K	CSK1 1.P 2.G 3.T
CSK-Touch	
K	CSKT + -
L	S8 Outdoor
M	CMSR +5V IN2 G

CONFIGURATION 22

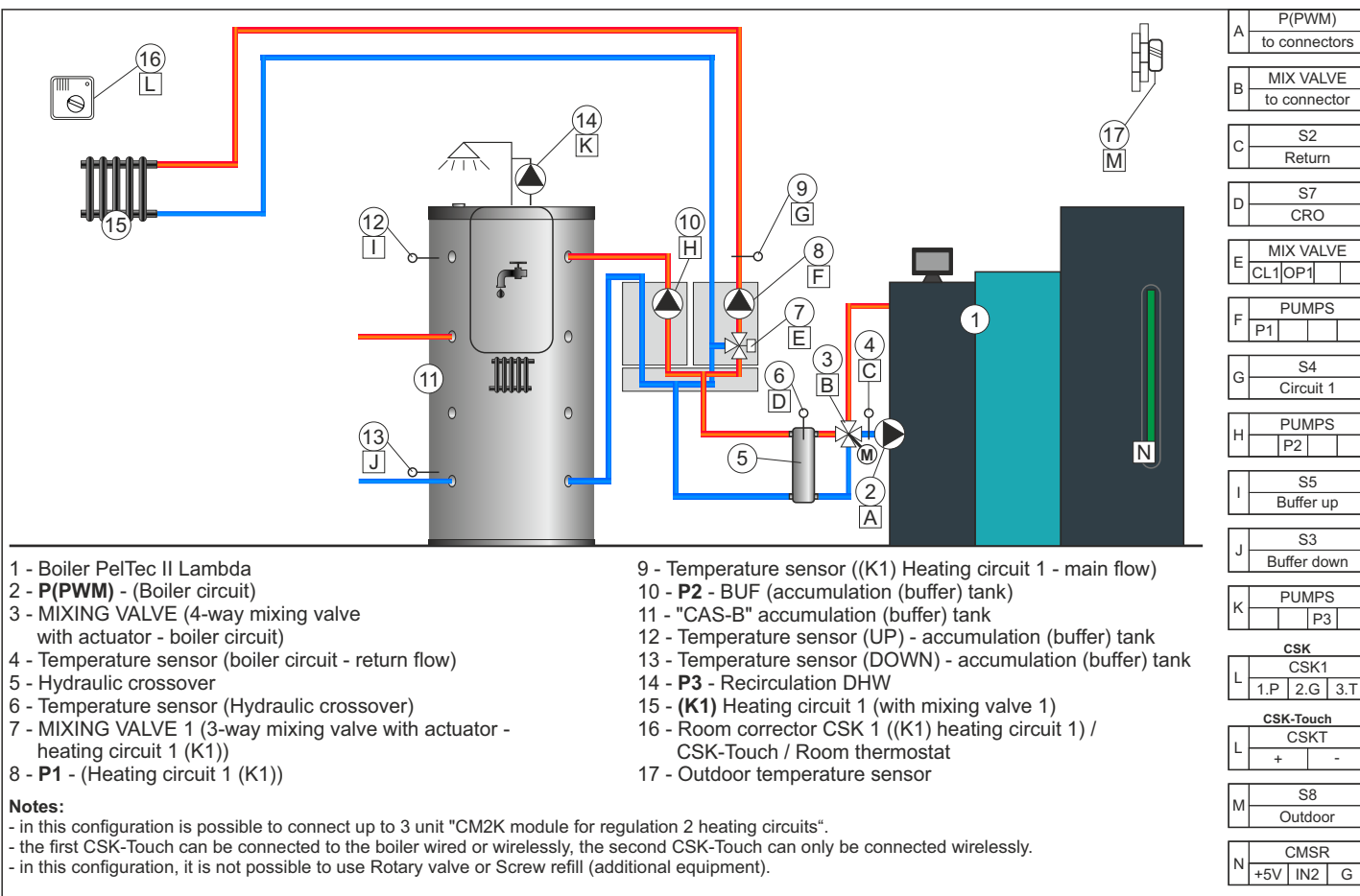

CONFIGURATION 23

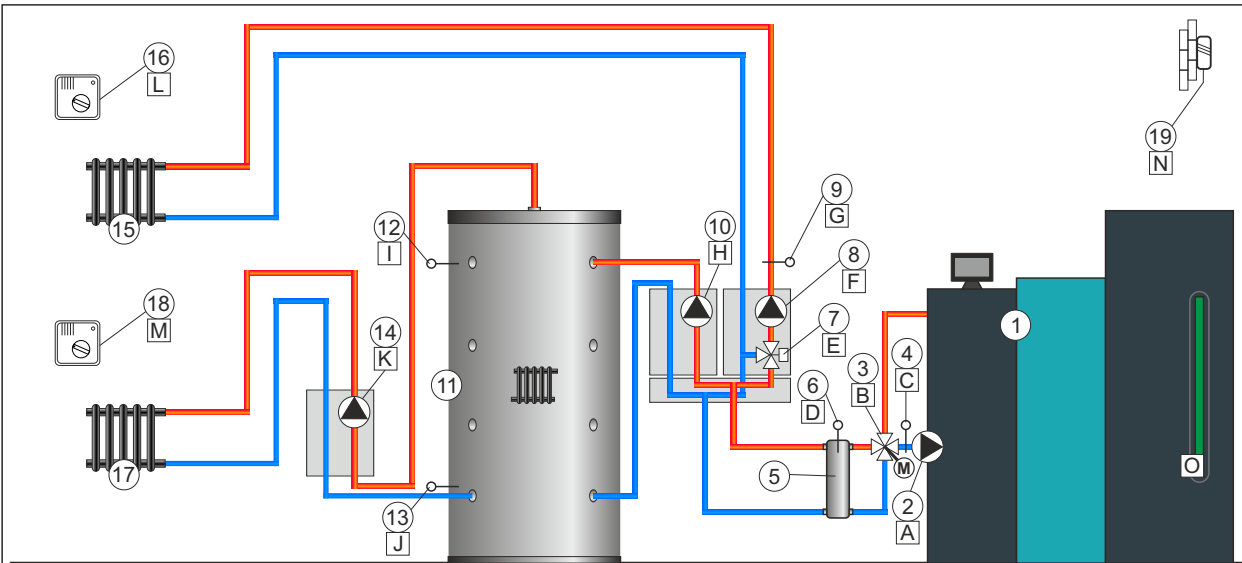

- 1 - Boiler PelTec II Lambda
- 2 - **P(PWM)** - (Boiler circuit)
- 3 - MIXING VALVE (4-way mixing valve with actuator - boiler circuit)
- 4 - Temperature sensor (boiler circuit - return flow)
- 5 - Hydraulic crossover
- 6 - Temperature sensor (Hydraulic crossover)
- 7 - MIXING VALVE 1 (3-way mixing valve with actuator - heating circuit 1 (K1))
- 8 - **P1** - (Heating circuit 1 (K1))
- 9 - Temperature sensor ((K1) Heating circuit 1 - main flow)
- 10 - **P2** - BUF (accumulation (buffer) tank)

- 11 - "CAS" accumulation (buffer) tank
- 12 - Temperature sensor (UP) - accumulation (buffer) tank
- 13 - Temperature sensor (DOWN) - accumulation (buffer) tank
- 14 - **P3** - (Heating circuit 2 (K2))
- 15 - (**K1**) Heating circuit 1 (with mixing valve 1)
- 16 - Room corrector CSK 1 ((K1) heating circuit 1) / CSK-Touch / Room thermostat
- 17 - (**K2**) Heating circuit 2 - (direct circuit)
- 18 - Room corrector CSK 2 ((K2) heating circuit 2) / CSK-Touch / Room thermostat
- 19 - Outdoor temperature sensor

Notes:

- in this configuration is possible to connect up to 3 unit "CM2K module for regulation 2 heating circuits".
- the first CSK-Touch can be connected to the boiler wired or wirelessly, the second CSK-Touch can only be connected wirelessly.
- in this configuration, it is not possible to use Rotary valve or Screw refill (additional equipment).

A	P(PWM) to connectors
B	MIX VALVE to connector
C	S2 Return
D	S7 CRO
E	MIX VALVE CL1 OP1
F	PUMPS P1
G	S4 Circuit 1
H	PUMPS P2
I	S5 Buffer up
J	S3 Buffer down
K	PUMPS P3
CSK 1	
L	CSK1 1.P 2.G 3.T
CSK-Touch 1	
L	CSKT + -
CSK 2	
M	CSK2 1.P 2.G 3.T
N	S8 Outdoor
O	
O	CMSR +5V IN2 G

CONFIGURATION 24

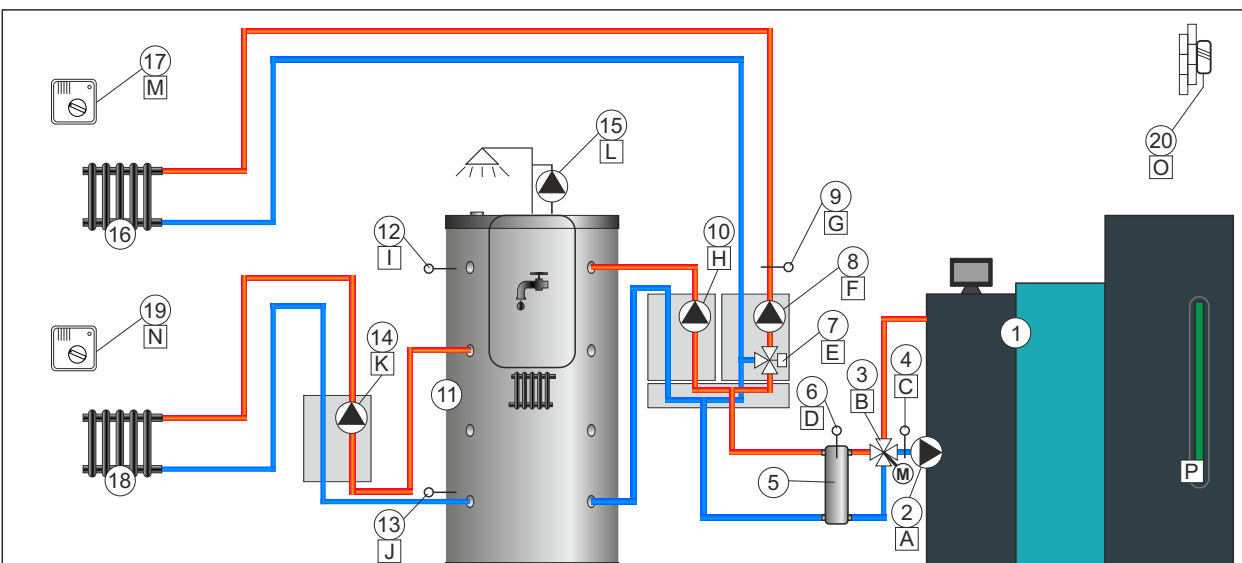

- 1 - Boiler PelTec II Lambda
- 2 - **P(PWM)** - (Boiler circuit)
- 3 - MIXING VALVE (4-way mixing valve with actuator - boiler circuit)
- 4 - Temperature sensor (boiler circuit - return flow)
- 5 - Hydraulic crossover
- 6 - Temperature sensor (Hydraulic crossover)
- 7 - MIXING VALVE 1 (3-way mixing valve with actuator - heating circuit 1 (K1))
- 8 - **P1** - (Heating circuit 1 (K1))
- 9 - Temperature sensor ((K1) Heating circuit 1 - main flow)
- 10 - **P2** - BUF (accumulation (buffer) tank)

- 11 - "CAS-B" accumulation (buffer) tank
- 12 - Temperature sensor (UP) - accumulation (buffer) tank
- 13 - Temperature sensor (DOWN) - accumulation (buffer) tank
- 14 - **P3** - (Heating circuit 2 (K2))
- 15 - **P4** - Recirculation DHW
- 16 - (**K1**) Heating circuit 1 (with mixing valve 1)
- 17 - Room corrector CSK 1 ((K1) heating circuit 1) / CSK-Touch / Room thermostat
- 18 - (**K2**) Heating circuit 2 - (direct circuit)
- 19 - Room corrector CSK 2 ((K2) heating circuit 2) / CSK-Touch / Room thermostat
- 20 - Outdoor temperature sensor

Notes:

- in this configuration is possible to connect up to 3 unit "CM2K module for regulation 2 heating circuits".
- the first CSK-Touch can be connected to the boiler wired or wirelessly, the second CSK-Touch can only be connected wirelessly.
- in this configuration, it is not possible to use Rotary valve and Screw refill (additional equipment).

A	P(PWM) to connectors
B	MIX VALVE to connector
C	S2 Return
D	S7 CRO
E	MIX VALVE CL1 OP1
F	PUMPS P1
G	S4 Circuit 1
H	PUMPS P2
I	S5 Buffer up
J	S3 Buffer down
K	PUMPS P3
L	PUMPS P4
M	CSK 1 CSK1 1.P 2.G 3.T
M	CSK-Touch 1 CSKT + -
N	CSK 2 CSK2 1.P 2.G 3.T
O	S8 Outdoor
P	CMSR +5V IN2 G

CONFIGURATION 25

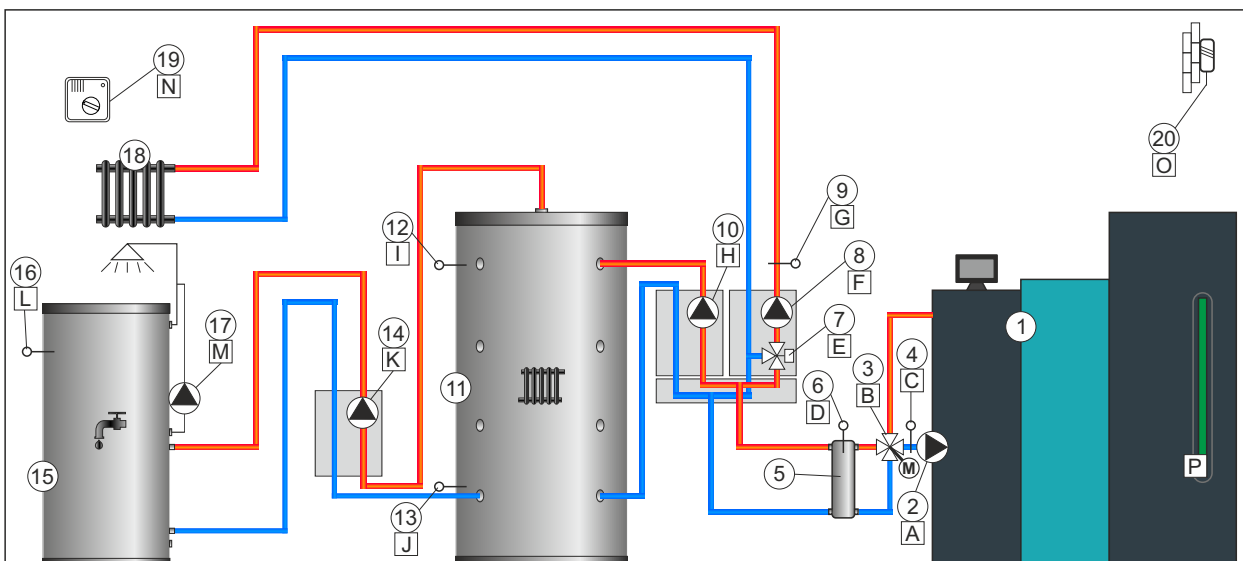

- 1 - Boiler PelTec II Lambda
- 2 - **P(PWM)** - (Boiler circuit)
- 3 - MIXING VALVE (4-way mixing valve with actuator - boiler circuit)
- 4 - Temperature sensor (boiler circuit - return flow)
- 5 - Hydraulic crossover
- 6 - Temperature sensor (Hydraulic crossover)
- 7 - MIXING VALVE 1 (3-way mixing valve with actuator - heating circuit 1 (K1))
- 8 - **P1** - (Heating circuit 1 (K1))
- 9 - Temperature sensor ((K1) Heating circuit 1 - main flow)

- 10 - **P2** - BUF (accumulation (buffer) tank)
- 11 - "CAS" accumulation (buffer) tank
- 12 - Temperature sensor (UP) - accumulation (buffer) tank
- 13 - Temperature sensor (DOWN) - accumulation (buffer) tank
- 14 - **P3** - DHW (Heating circuit 2 (K2))
- 15 - ((K2) Heating circuit 2 (DHW))
- 16 - Temperature sensor DHW ((K2) Heating circuit 2)
- 17 - **P4** - Recirculation DHW (Heating circuit 2 (K2))
- 18 - ((K1) Heating circuit 1 (with mixing valve 1))
- 19 - Room corrector CSK 1 ((K1) heating circuit 1) / CSK-Touch / Room thermostat
- 20 - Outdoor temperature sensor

Notes:

- in this configuration is possible to connect up to 3 unit "CM2K module for regulation 2 heating circuits".
- the first CSK-Touch can be connected to the boiler wired or wirelessly, the second CSK-Touch can only be connected wirelessly.
- in this configuration, it is not possible to use Rotary valve and Screw refill (additional equipment).

A	P(PWM) to connectors
B	MIX VALVE to connector
C	S2 Return
D	S7 CRO
E	MIX VALVE CL1 OP1
F	PUMPS
G	S4 Circuit 1
H	PUMPS
I	S5 Buffer up
J	S3 Buffer down
K	PUMPS
L	S6 Circuit 2
M	PUMPS
N	CSK CSK1 1.P 2.G 3.T
O	CSK-Touch CSKT + -
P	S8 Outdoor
	CMSR +5V IN2 G

CONFIGURATION 26

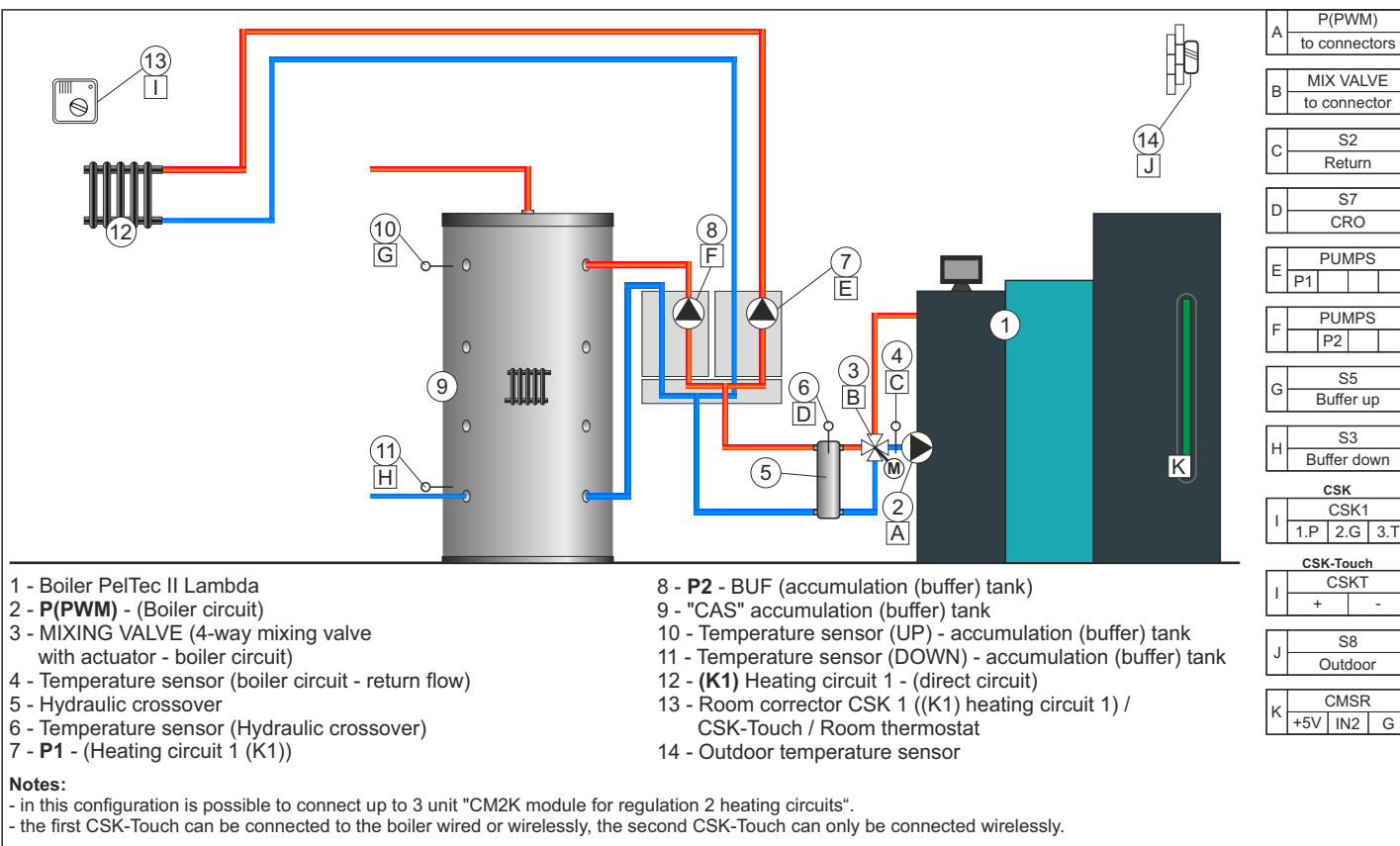

CONFIGURATION 27

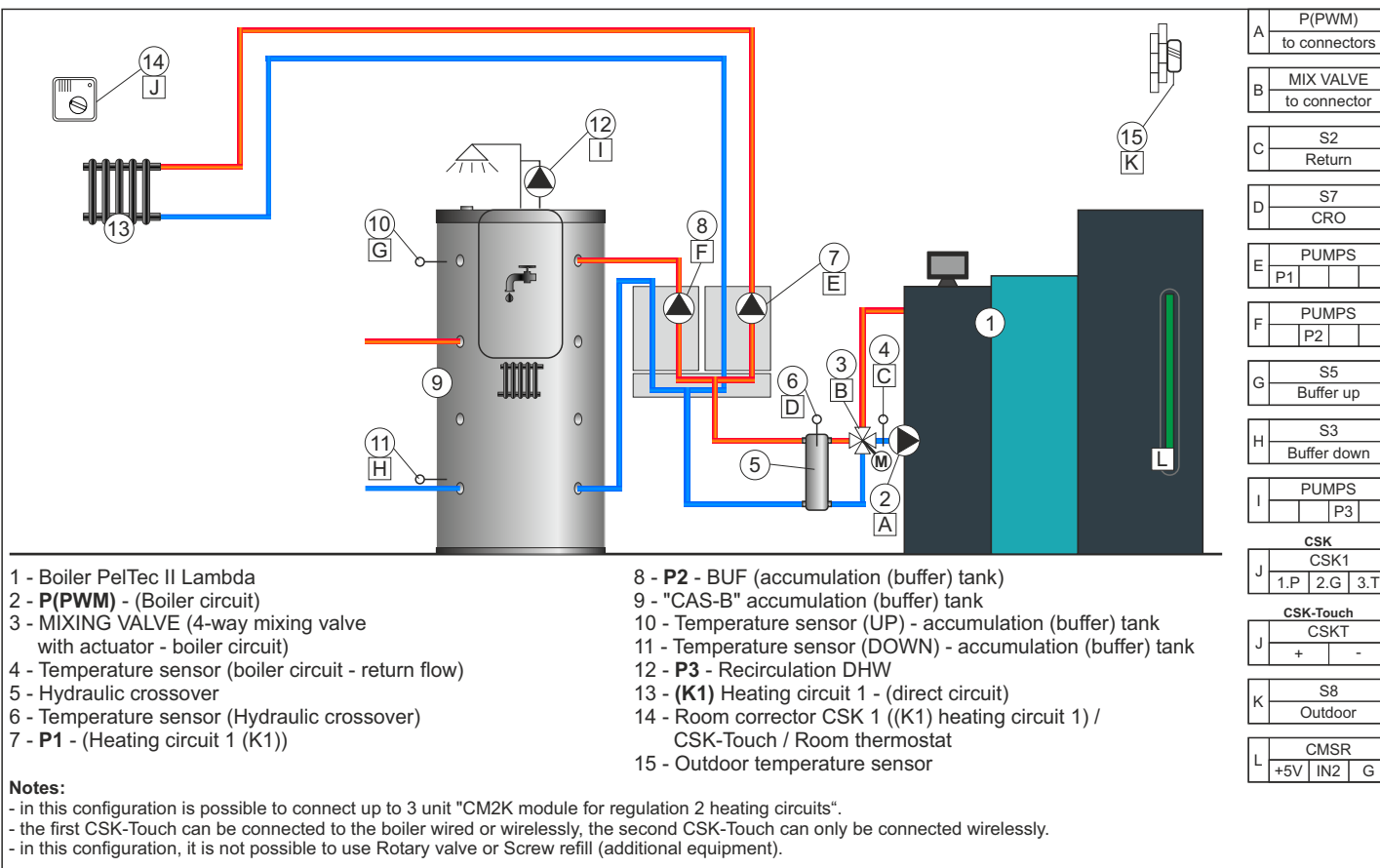

CONFIGURATION 28

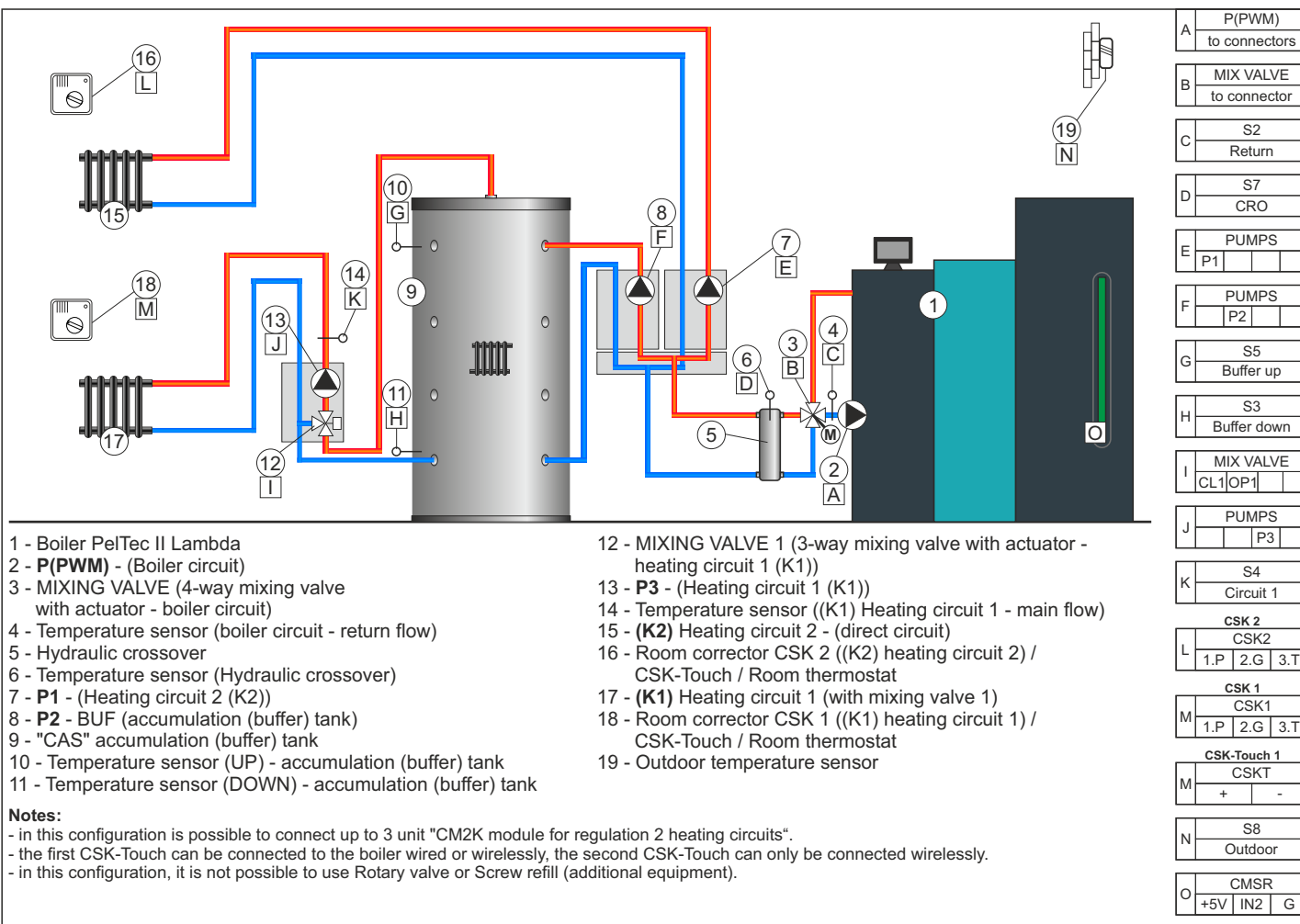

CONFIGURATION 29

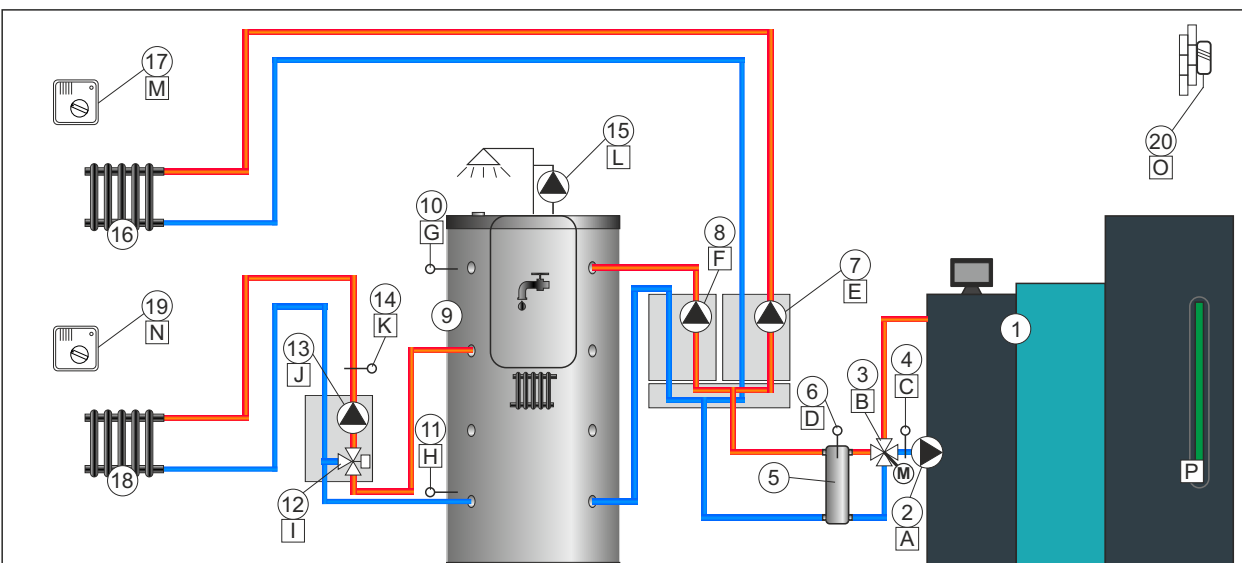

- 1 - Boiler PelTec II Lambda
- 2 - **P(PWM)** - (Boiler circuit)
- 3 - MIXING VALVE (4-way mixing valve with actuator - boiler circuit)
- 4 - Temperature sensor (boiler circuit - return flow)
- 5 - Hydraulic crossover
- 6 - Temperature sensor (Hydraulic crossover)
- 7 - **P1** - (Heating circuit 2 (K2))
- 8 - **P2** - BUF (accumulation (buffer) tank)
- 9 - "CAS-B" accumulation (buffer) tank
- 10 - Temperature sensor (UP) - accumulation (buffer) tank
- 11 - Temperature sensor (DOWN) - accumulation (buffer) tank

- 12 - MIXING VALVE 1 (3-way mixing valve with actuator - heating circuit 1 (K1))
- 13 - **P3** - (Heating circuit 1 (K1))
- 14 - Temperature sensor ((K1) Heating circuit 1 - main flow)
- 15 - **P4** - Recirculation DHW
- 16 - (**K2**) Heating circuit 2 - (direct circuit)
- 17 - Room corrector CSK 2 ((K2) heating circuit 2) / CSK-Touch / Room thermostat
- 18 - (**K1**) Heating circuit 1 (with mixing valve 1)
- 19 - Room corrector CSK 1 ((K1) heating circuit 1) / CSK-Touch / Room thermostat
- 20 - Outdoor temperature sensor

Notes:

- in this configuration is possible to connect up to 3 unit "CM2K module for regulation 2 heating circuits".
- the first CSK-Touch can be connected to the boiler wired or wirelessly, the second CSK-Touch can only be connected wirelessly.
- in this configuration, it is not possible to use Rotary valve and Screw refill (additional equipment).

A	P(PWM) to connectors
B	MIX VALVE to connector
C	S2 Return
D	S7 CRO
E	PUMPS P1
F	PUMPS P2
G	S5 Buffer up
H	S3 Buffer down
I	MIX VALVE CL1 OP1
J	PUMPS P3
K	S4 Circuit 1
L	PUMPS P4
M	CSK 2 CSK2 1.P 2.G 3.T
N	CSK 1 CSK1 1.P 2.G 3.T
O	CSK-Touch 1 CSKT + -
P	S8 Outdoor
P	CMSR +5V IN2 G

CONFIGURATION 30

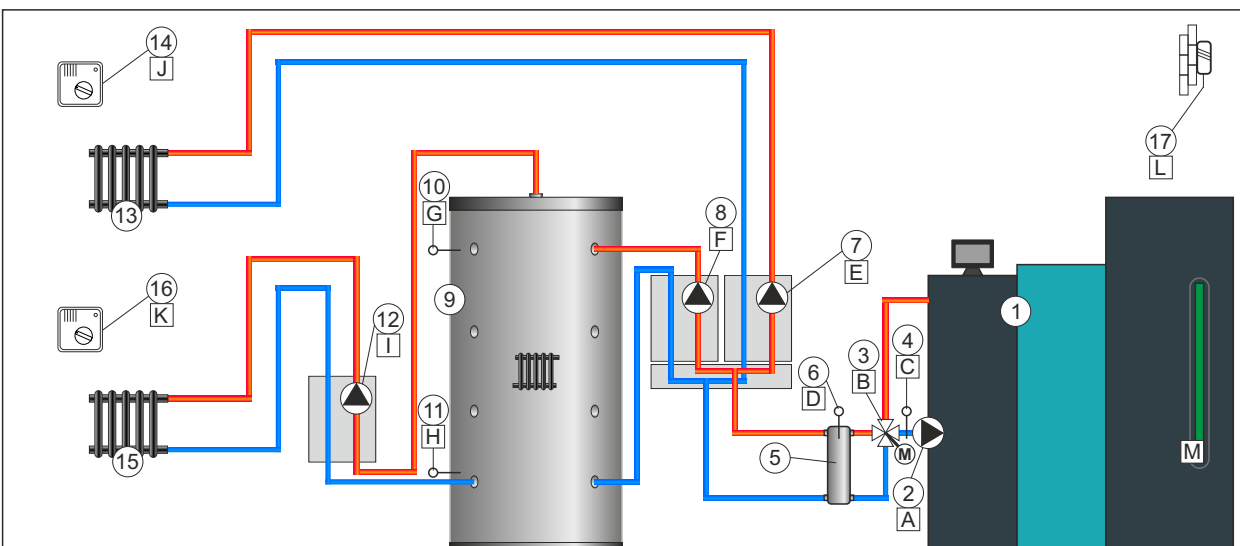

- 1 - Boiler PelTec II Lambda
- 2 - **P(PWM)** - (Boiler circuit)
- 3 - MIXING VALVE (4-way mixing valve with actuator - boiler circuit)
- 4 - Temperature sensor (boiler circuit - return flow)
- 5 - Hydraulic crossover
- 6 - Temperature sensor (Hydraulic crossover)
- 7 - **P1** - (Heating circuit 1 (K1))
- 8 - **P2** - BUF (accumulation (buffer) tank)
- 9 - "CAS" accumulation (buffer) tank

- 10 - Temperature sensor (UP) - accumulation (buffer) tank
- 11 - Temperature sensor (DOWN) - accumulation (buffer) tank
- 12 - **P3** - (Heating circuit 2 (K2))
- 13 - (**K1**) Heating circuit 1 - (direct circuit)
- 14 - Room corrector CSK 1 ((K1) heating circuit 1) / CSK-Touch / Room thermostat
- 15 - (**K2**) Heating circuit 2 - (direct circuit)
- 16 - Room corrector CSK 2 ((K2) heating circuit 2) / CSK-Touch / Room thermostat
- 17 - Outdoor temperature sensor

Notes:

- in this configuration is possible to connect up to 3 unit "CM2K module for regulation 2 heating circuits".
- the first CSK-Touch can be connected to the boiler wired or wirelessly, the second CSK-Touch can only be connected wirelessly.
- in this configuration, it is not possible to use Rotary valve or Screw refill (additional equipment).

A	P(PWM) to connectors
B	MIX VALVE to connector
C	S2 Return
D	S7 CRO
E	PUMPS P1
F	PUMPS P2
G	S5 Buffer up
H	S3 Buffer down
I	PUMPS P3
CSK 1	
J	CSK1 1.P 2.G 3.T
CSK-Touch 1	
J	CSKT + -
CSK 2	
K	CSK2 1.P 2.G 3.T
L	S8 Outdoor
M	CMSR +5V IN2 G

CONFIGURATION 31

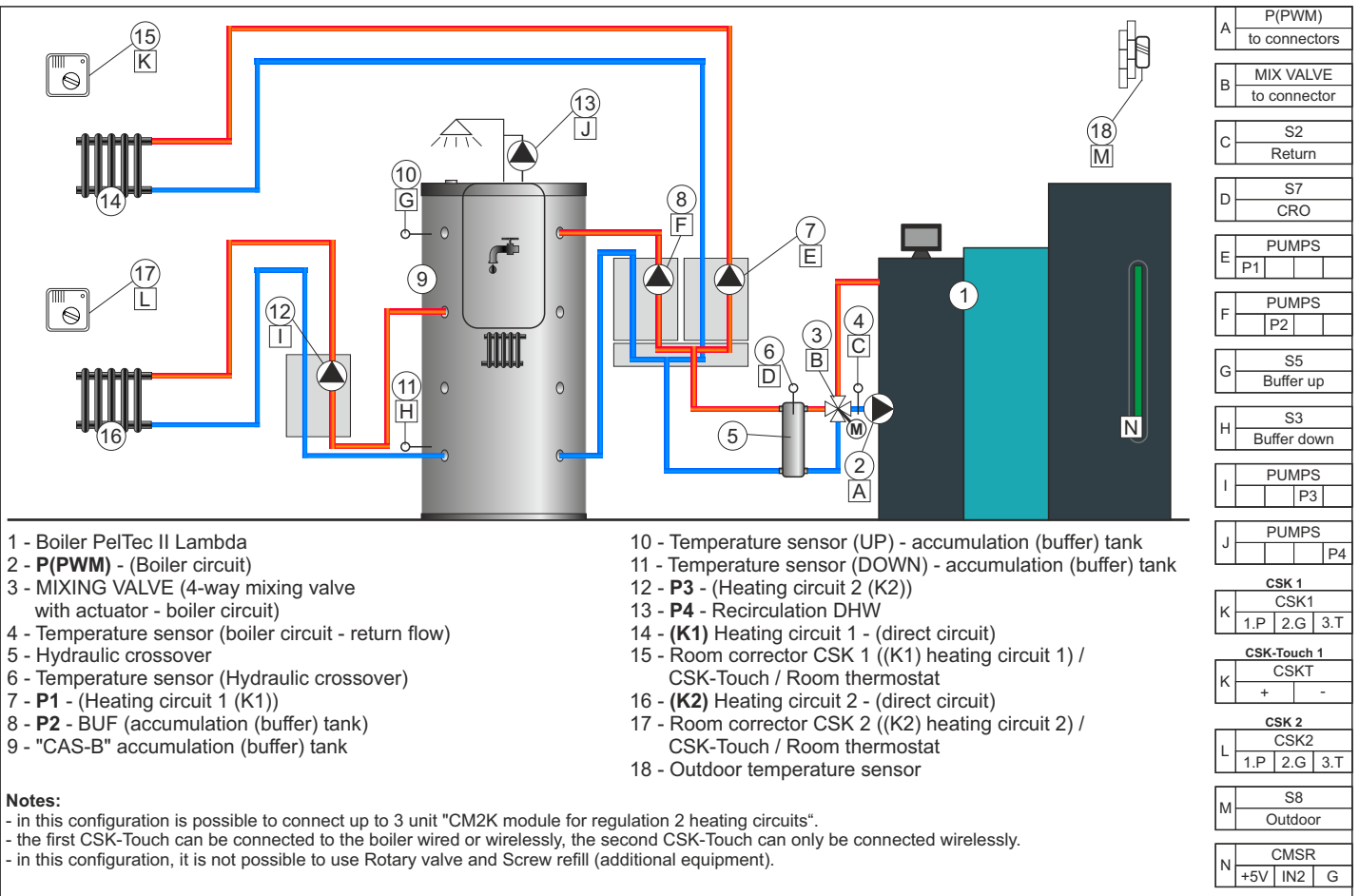

CONFIGURATION 32

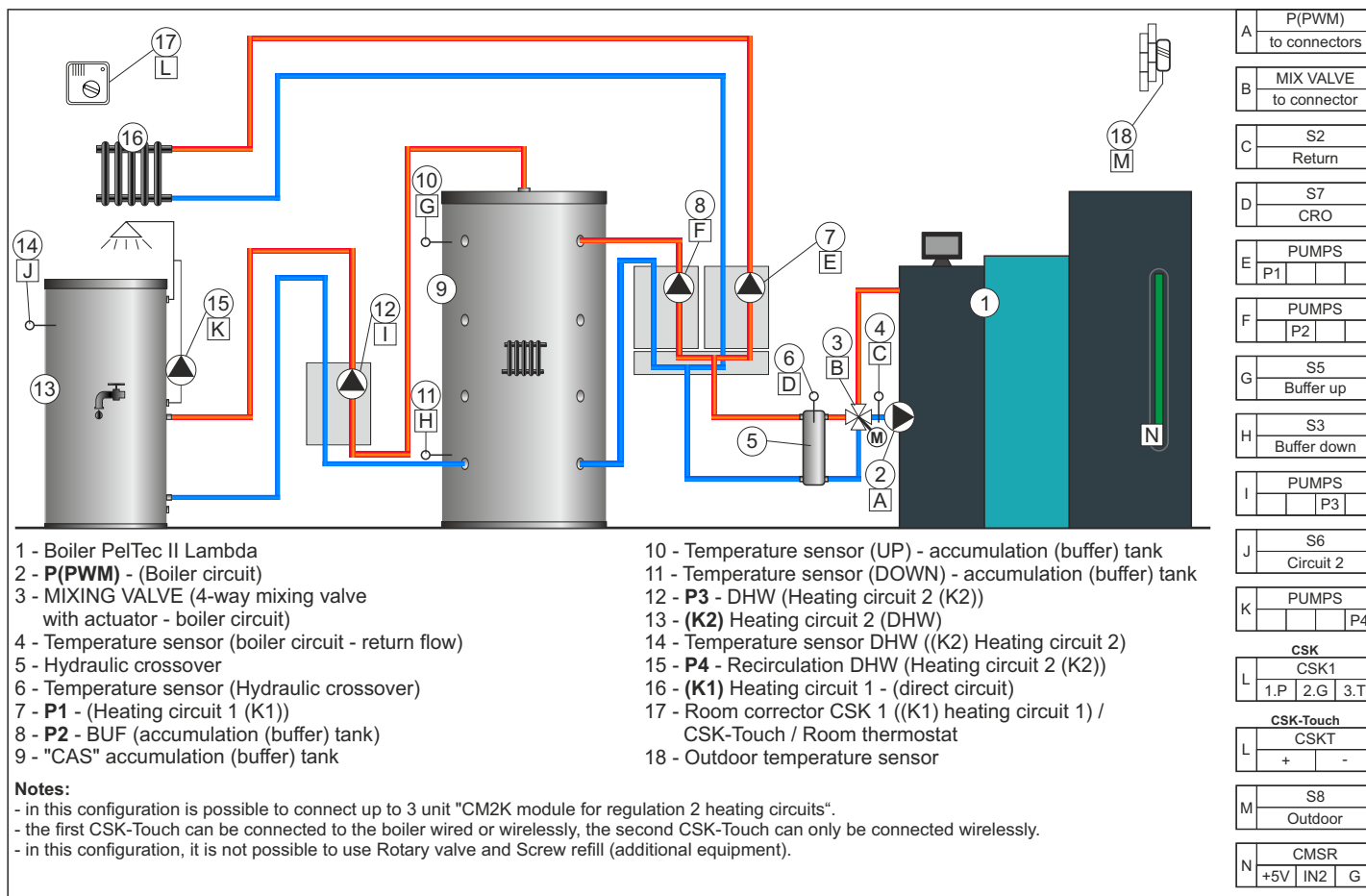

CONFIGURATION 33

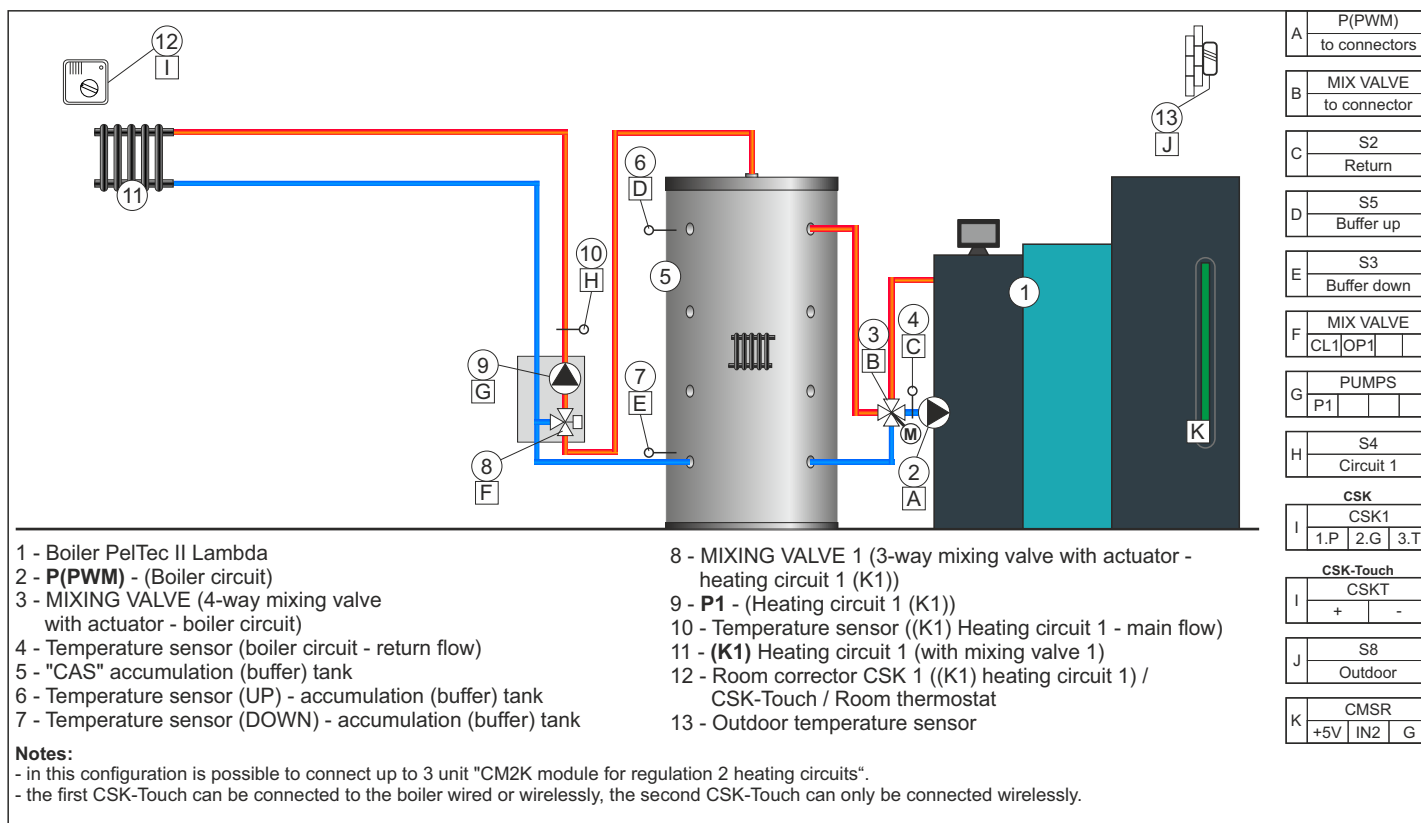

CONFIGURATION 34

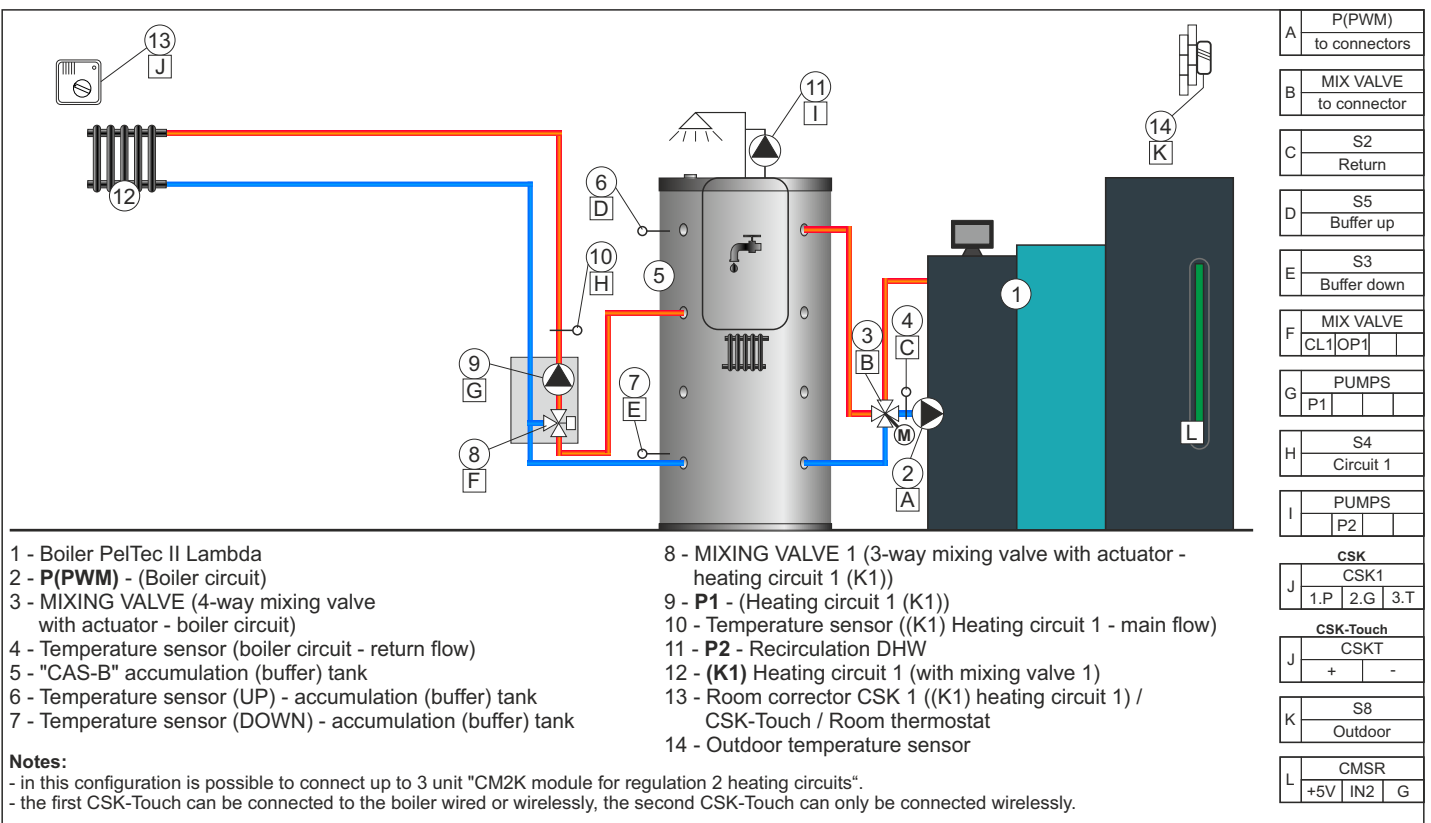

CONFIGURATION 35

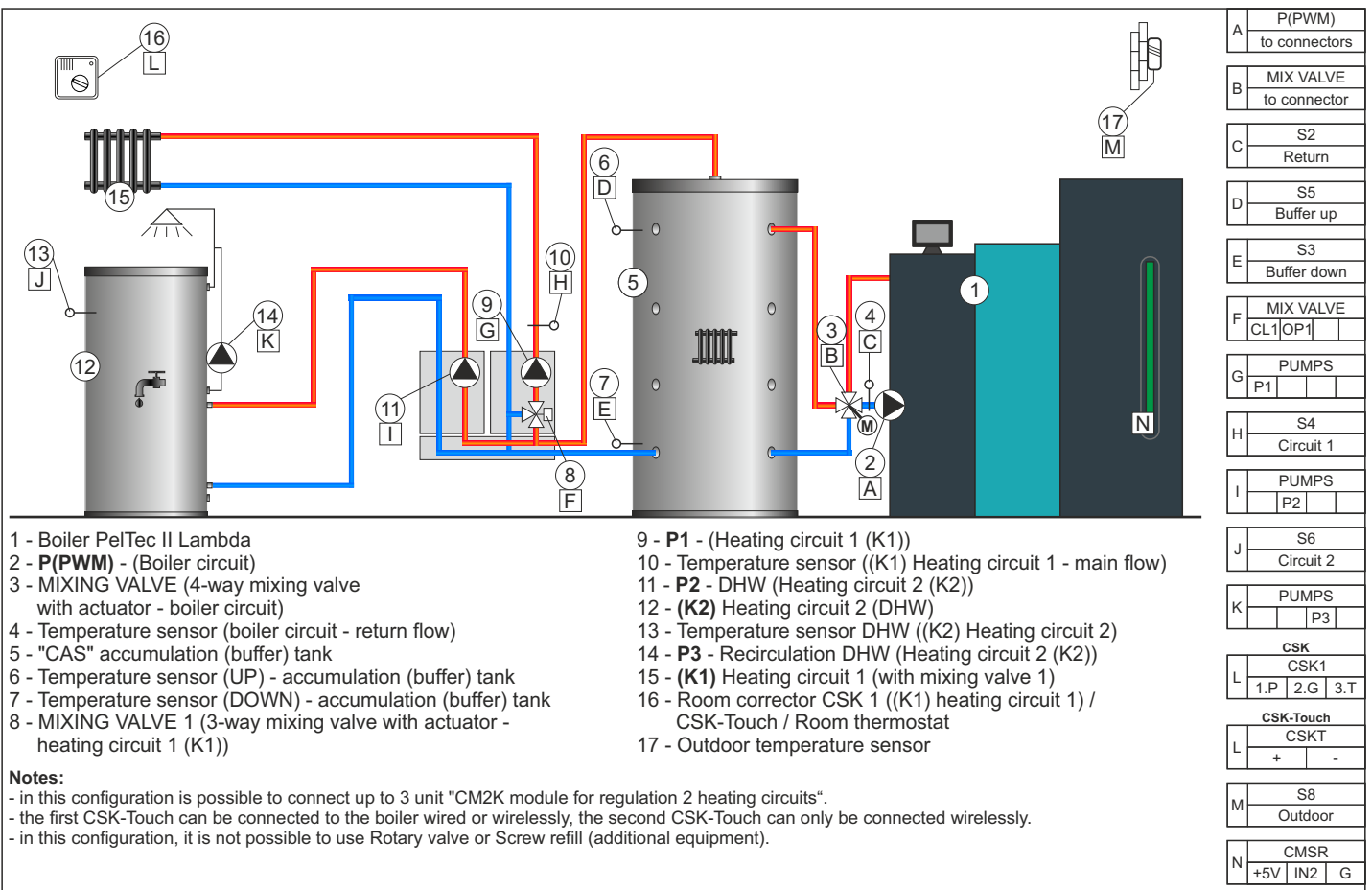

CONFIGURATION 36

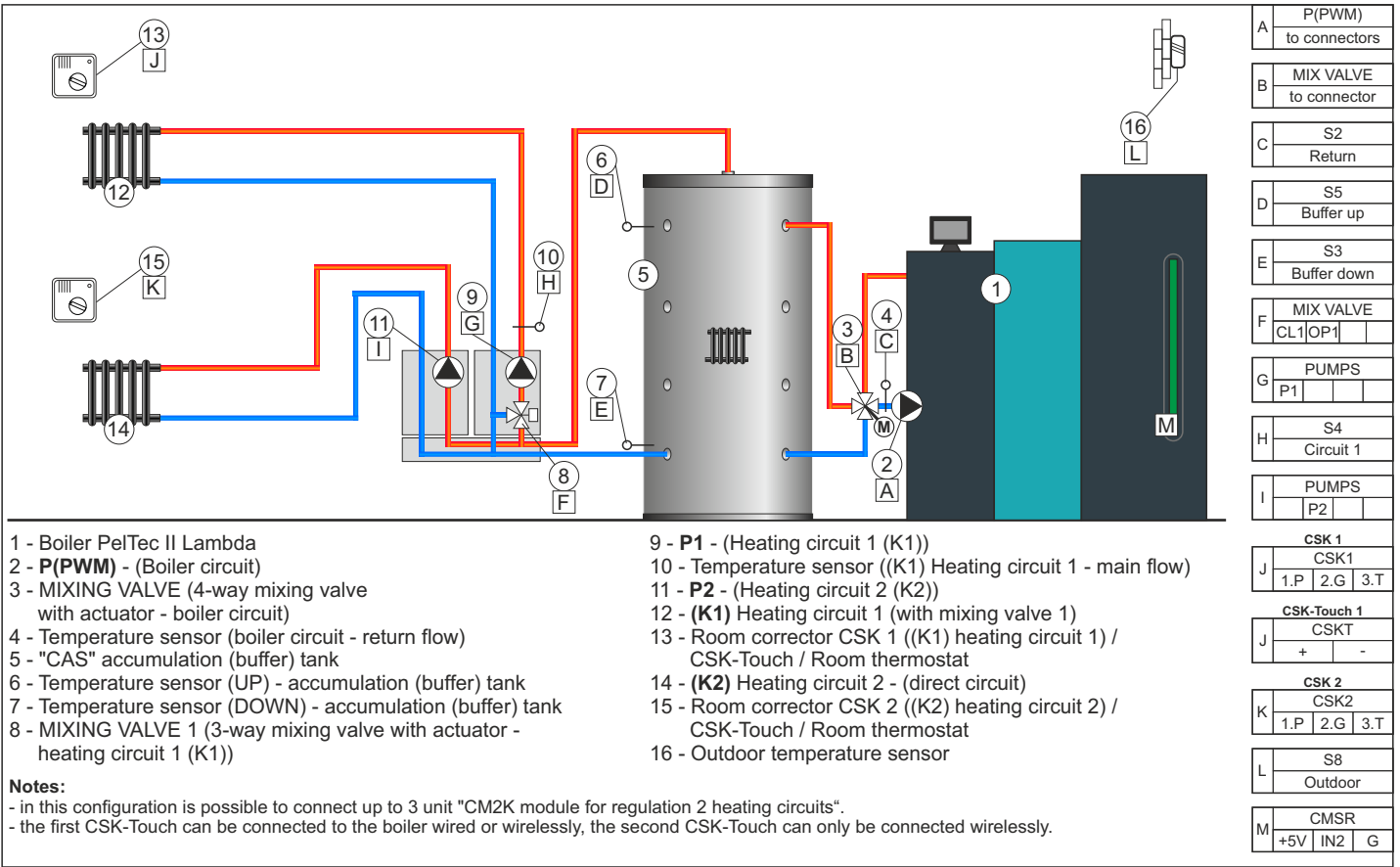

CONFIGURATION 37

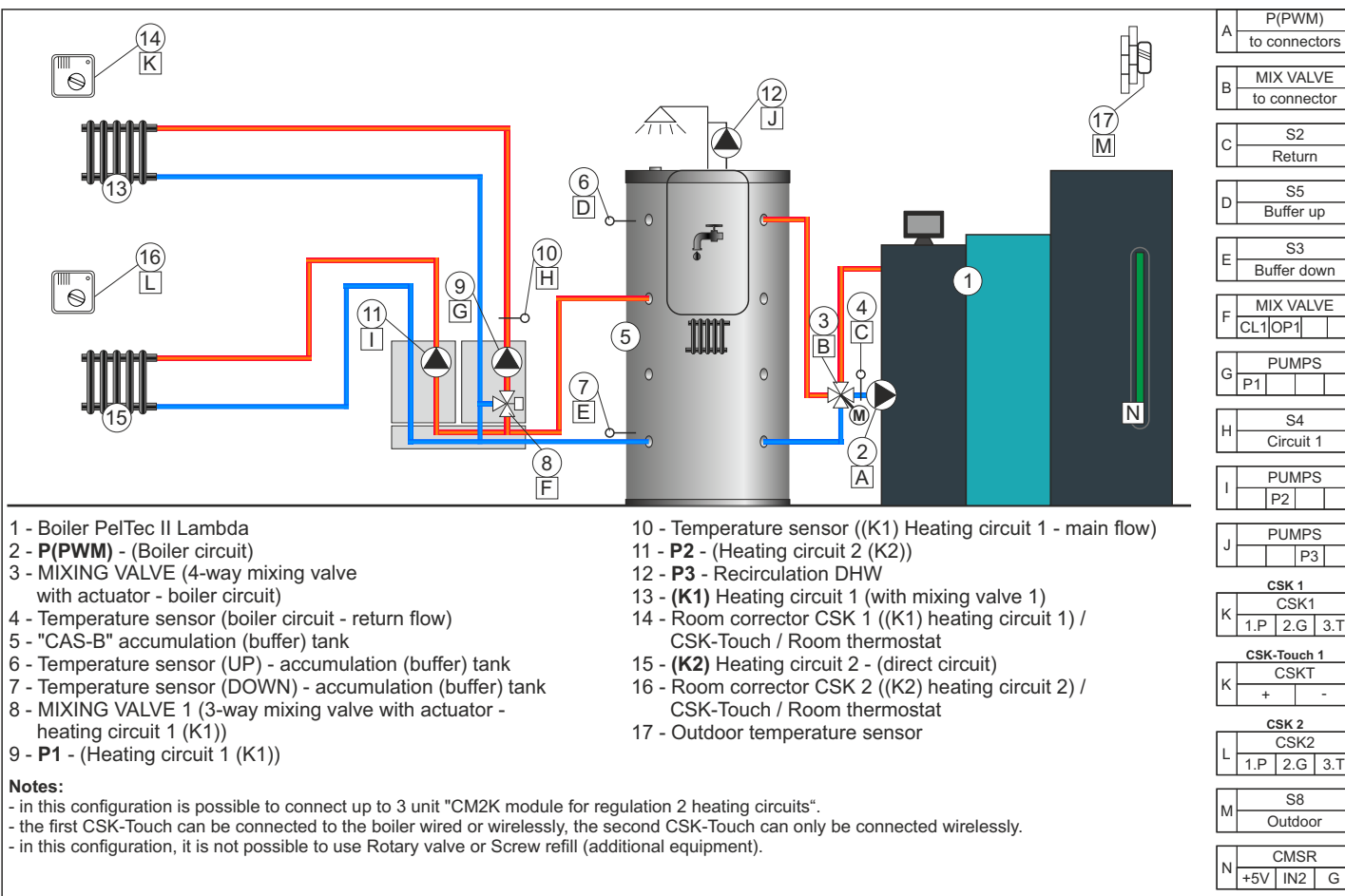

CONFIGURATION 38

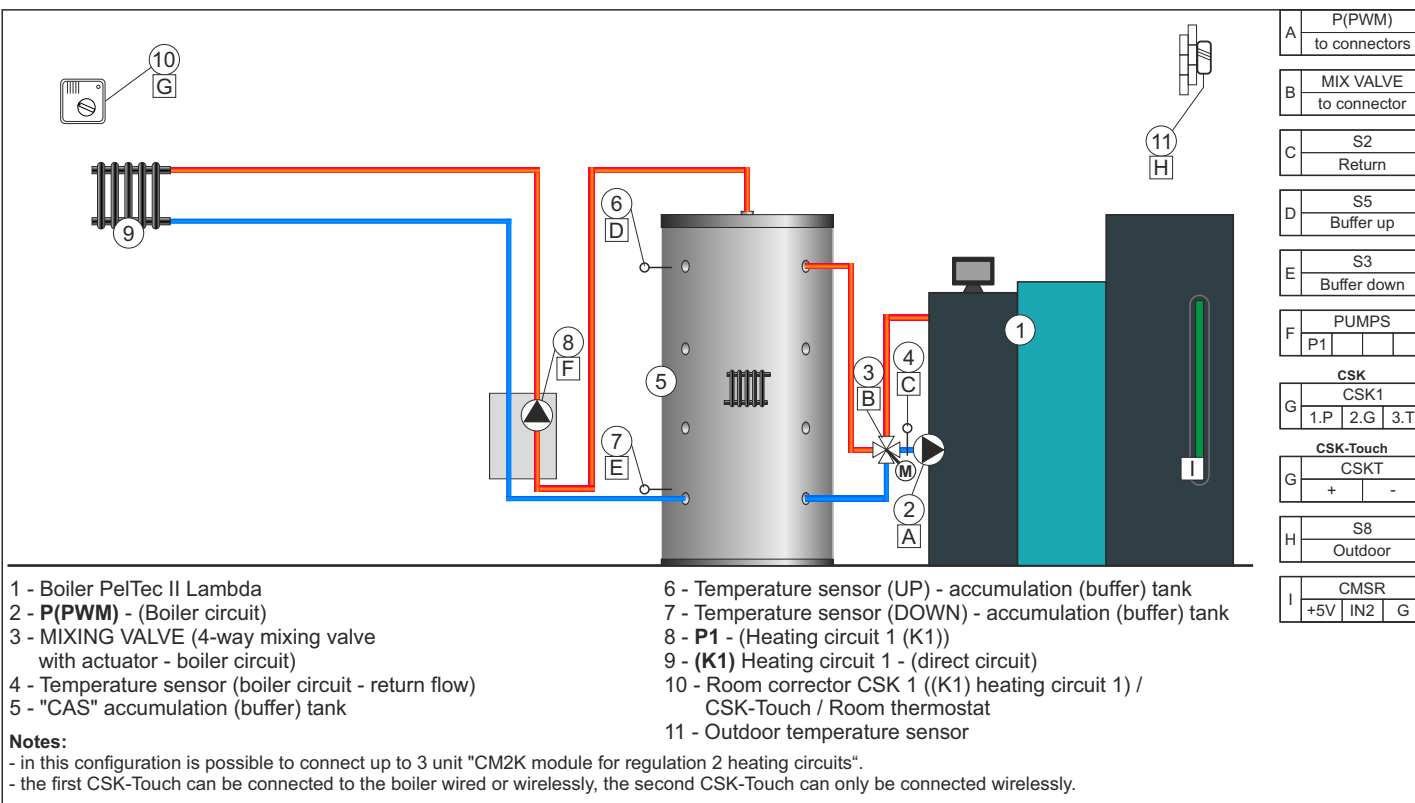

CONFIGURATION 39

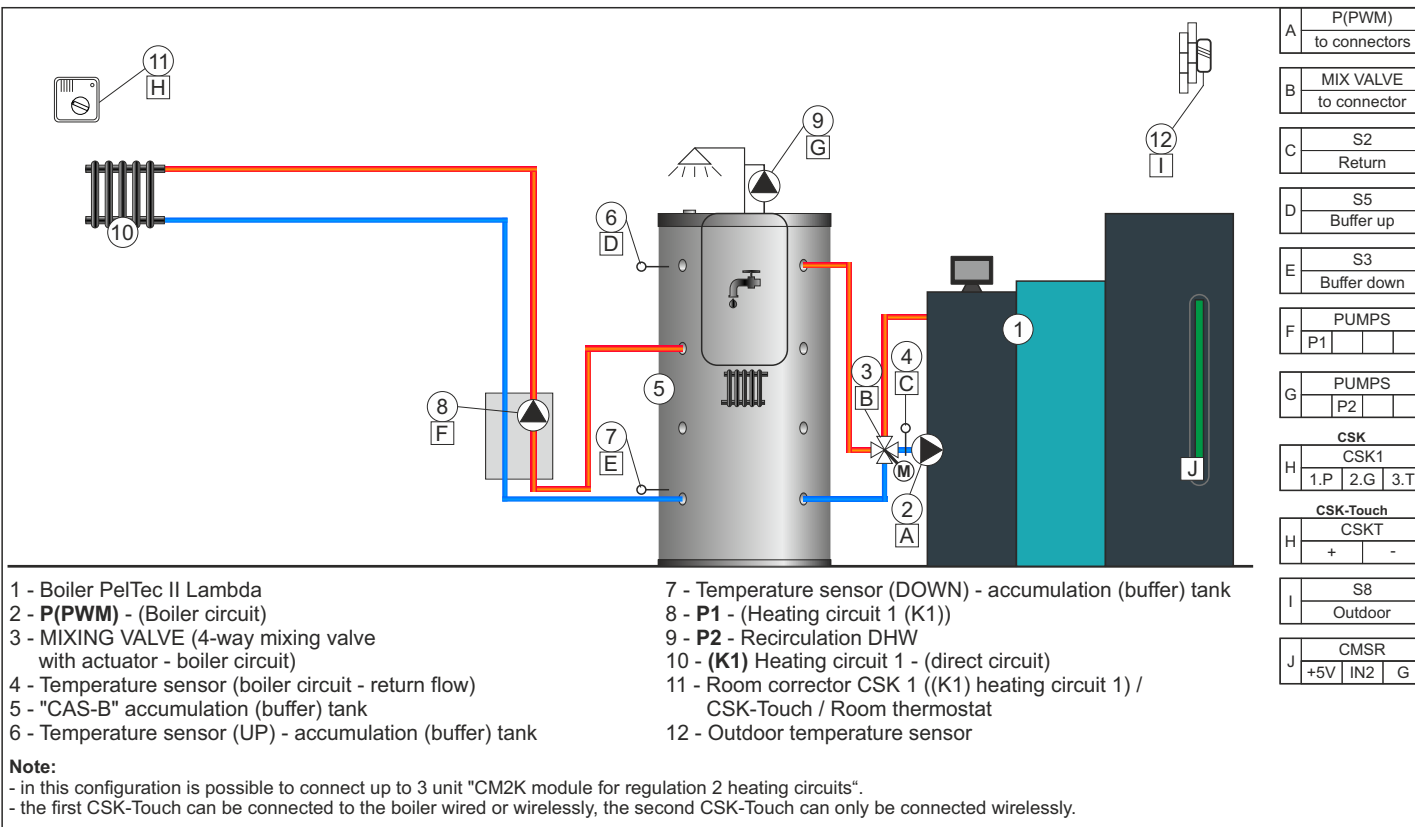

CONFIGURATION 40

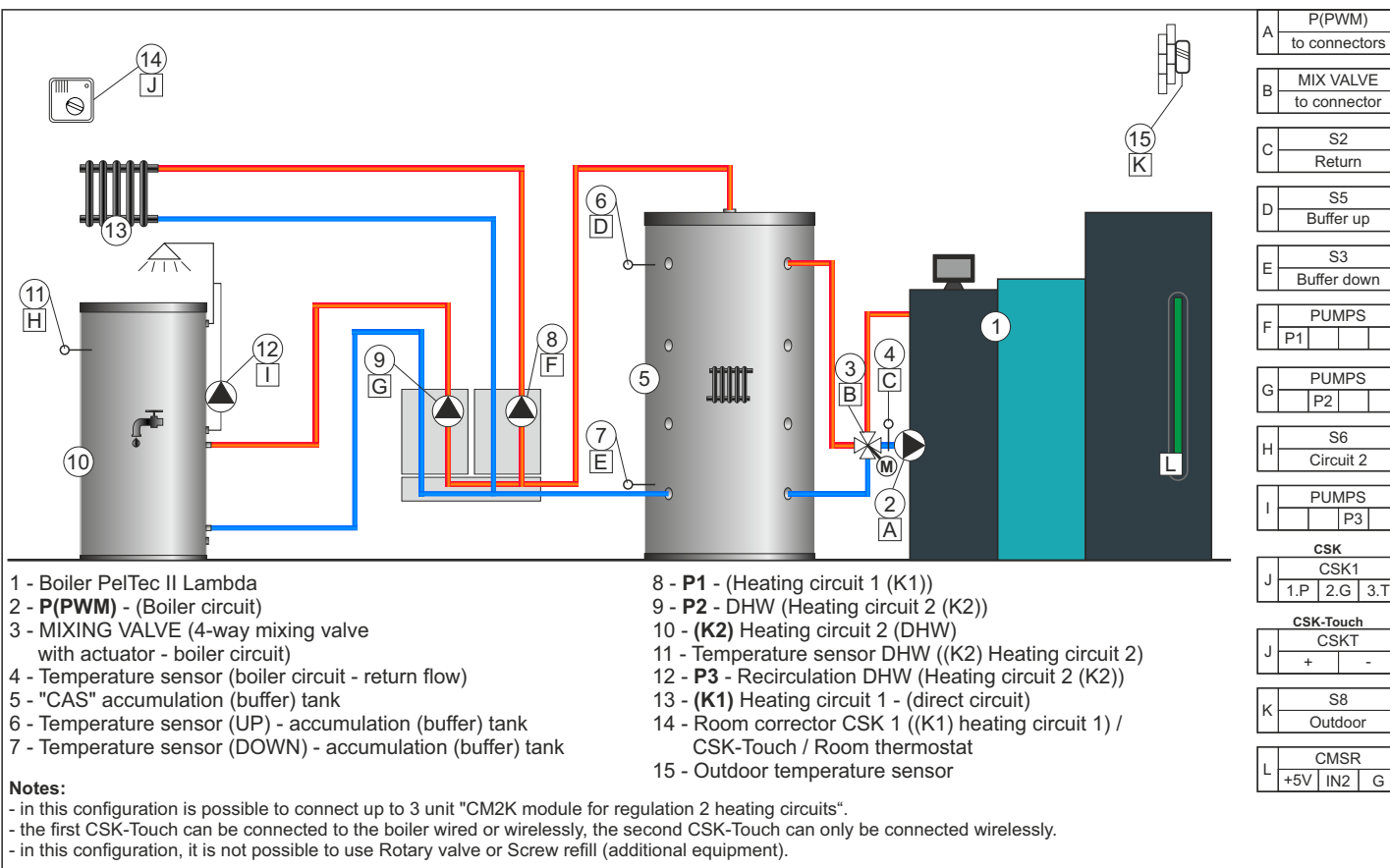

CONFIGURATION 41

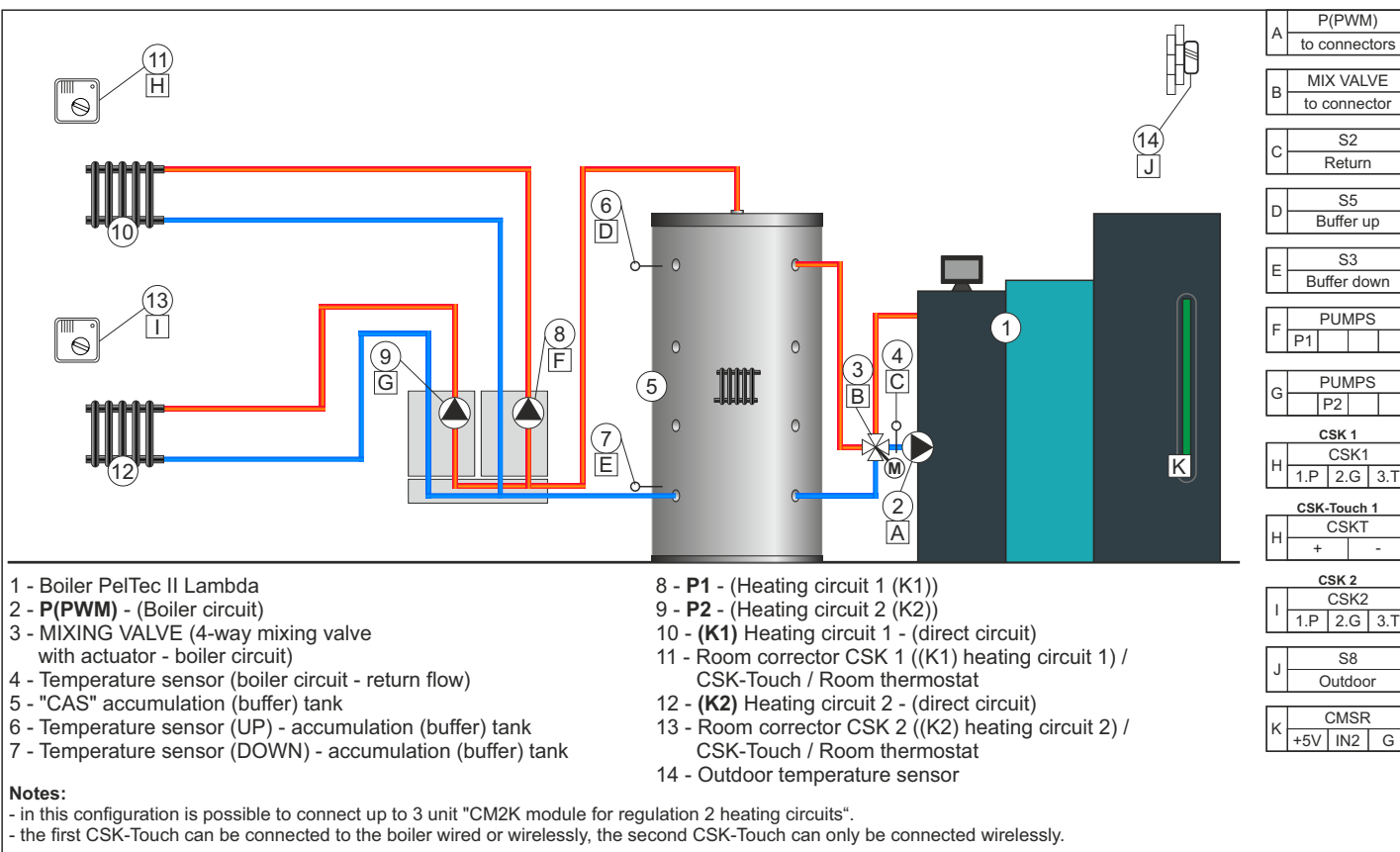

CONFIGURATION 42

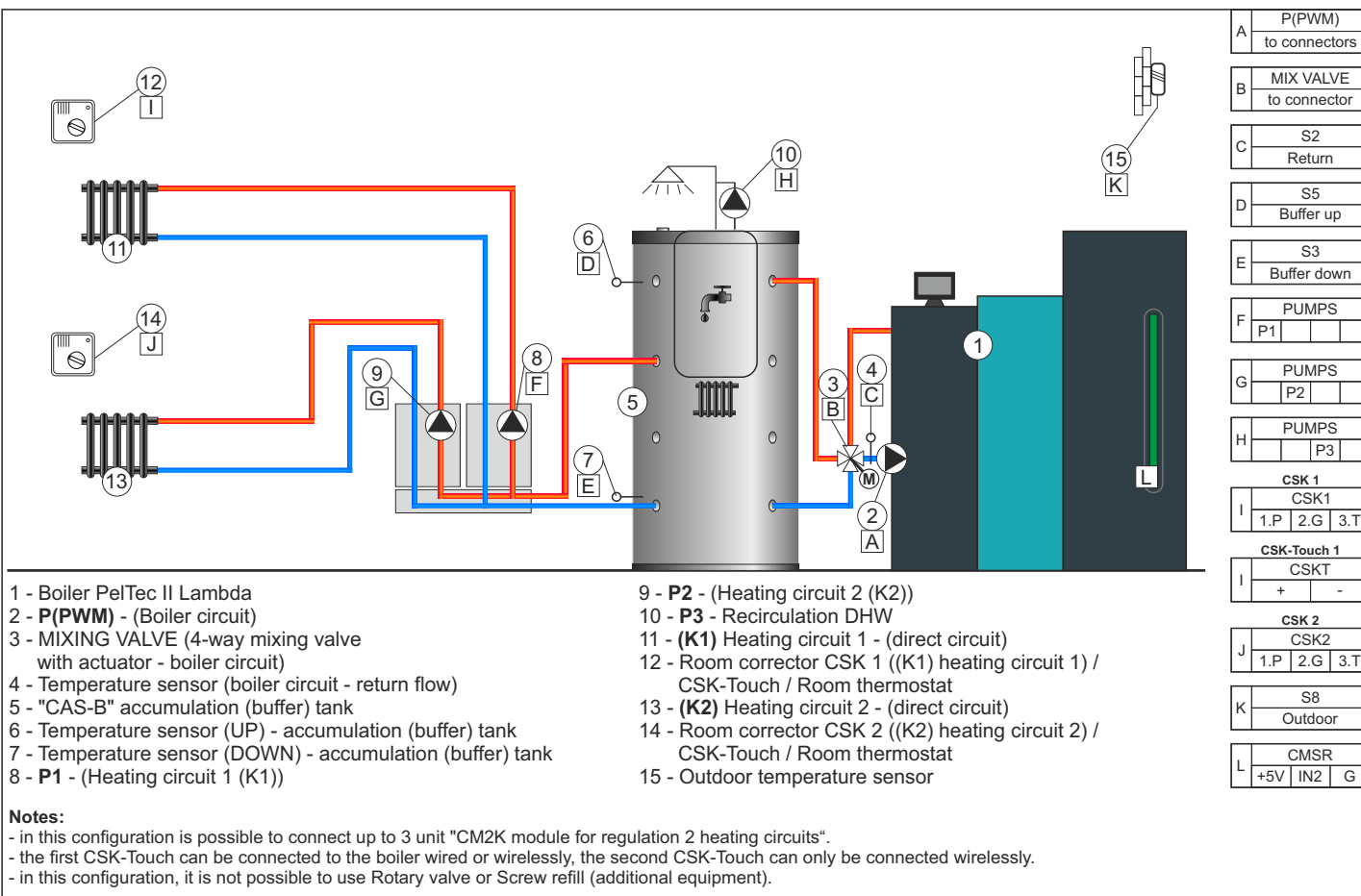

CONFIGURATION 43

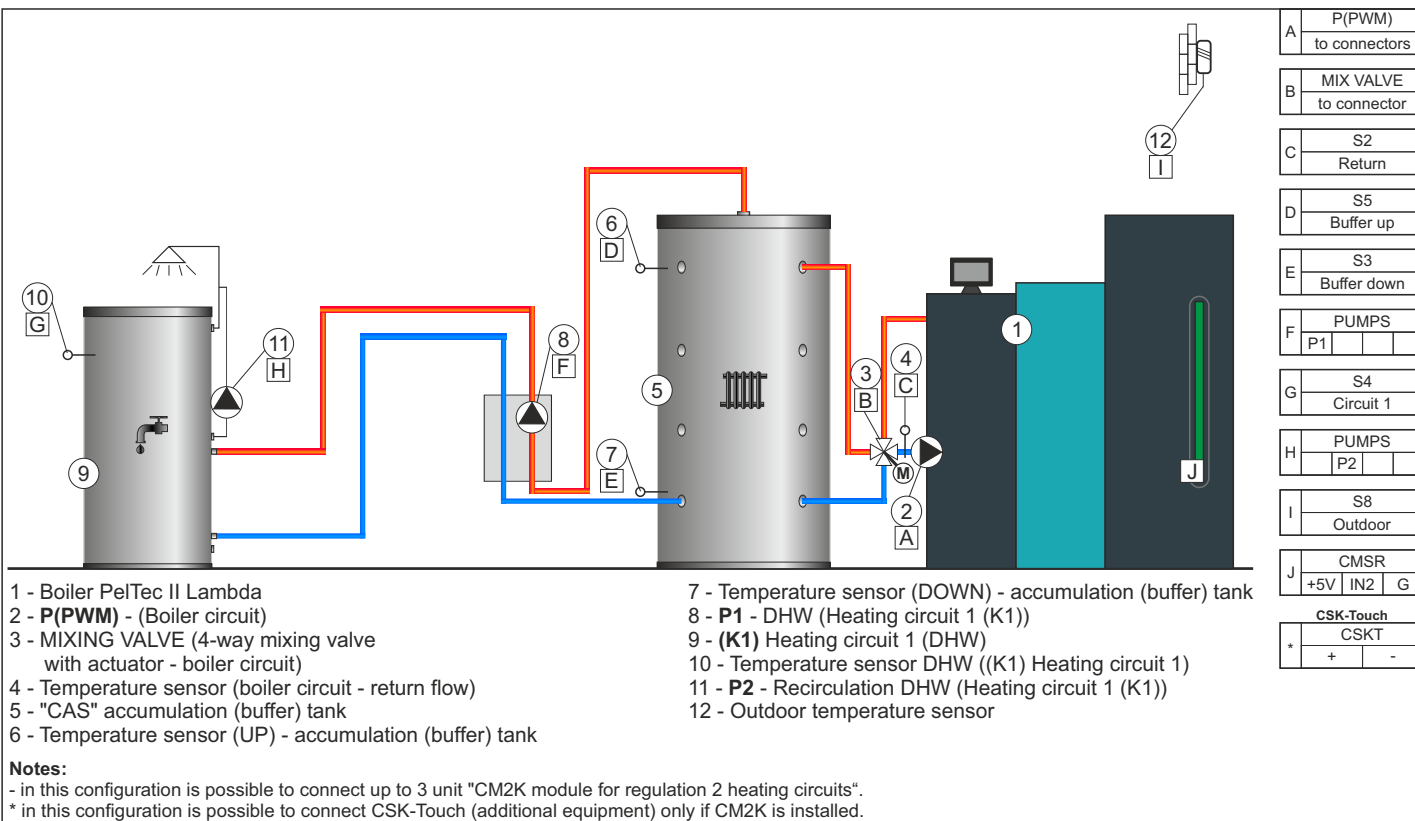

CONFIGURATION 44

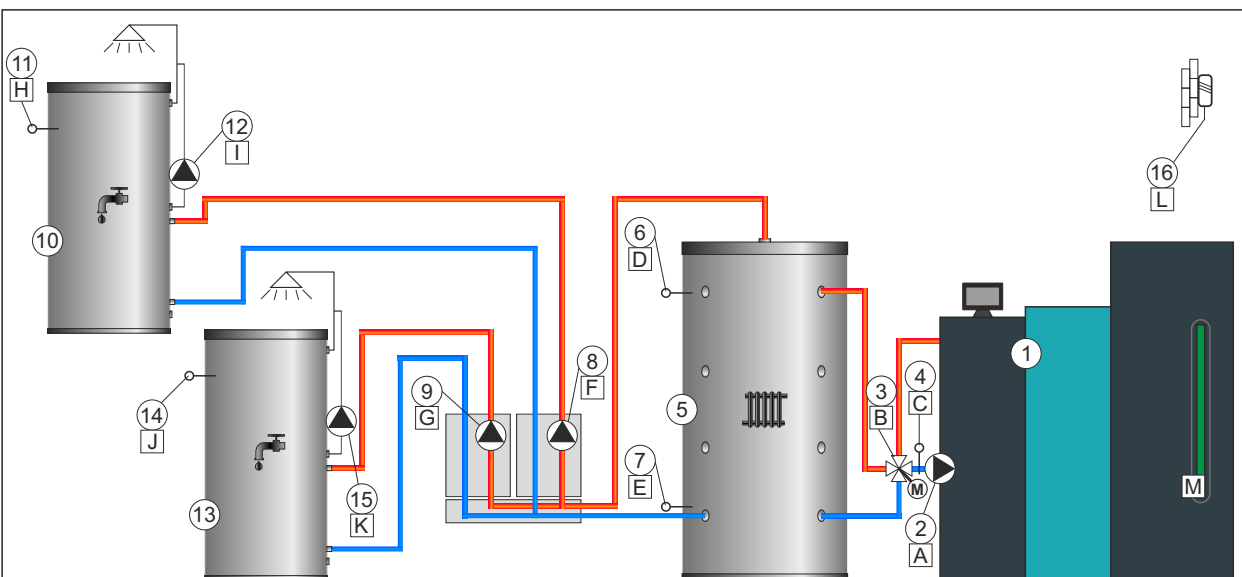

- 1 - Boiler PelTec II Lambda
- 2 - **P(PWM)** - (Boiler circuit)
- 3 - MIXING VALVE (4-way mixing valve with actuator - boiler circuit)
- 4 - Temperature sensor (boiler circuit - return flow)
- 5 - "CAS" accumulation (buffer) tank
- 6 - Temperature sensor (UP) - accumulation (buffer) tank
- 7 - Temperature sensor (DOWN) - accumulation (buffer) tank
- 8 - **P1** - DHW (Heating circuit 1 (K1))
- 9 - **P2** - DHW (Heating circuit 2 (K2))
- 10 - **(K1)** Heating circuit 1 (DHW)
- 11 - Temperature sensor DHW ((K1) Heating circuit 1)
- 12 - **P3** - Recirculation DHW (Heating circuit 1 (K1))
- 13 - **(K2)** Heating circuit 2 (DHW)
- 14 - Temperature sensor DHW ((K2) Heating circuit 2)
- 15 - **P4** - Recirculation DHW (Heating circuit 2 (K2))
- 16 - Outdoor temperature sensor

Notes:

- in this configuration is possible to connect up to 3 unit "CM2K module for regulation 2 heating circuits".
- in this configuration, it is not possible to use Rotary valve and Screw refill (additional equipment).
- * in this configuration is possible to connect CSK-Touch (additional equipment) only if CM2K is installed.

A	P(PWM) to connectors
B	MIX VALVE to connector
C	S2 Return
D	S5 Buffer up
E	S3 Buffer down
F	PUMPS P1
G	PUMPS P2
H	S4 Circuit 1
I	PUMPS P3
J	S6 Circuit 2
K	PUMPS P4
L	S8 Outdoor
M	CMSR +5V IN2 G
CSK-Touch	
*	CSKT
	+ -

CONFIGURATION 45

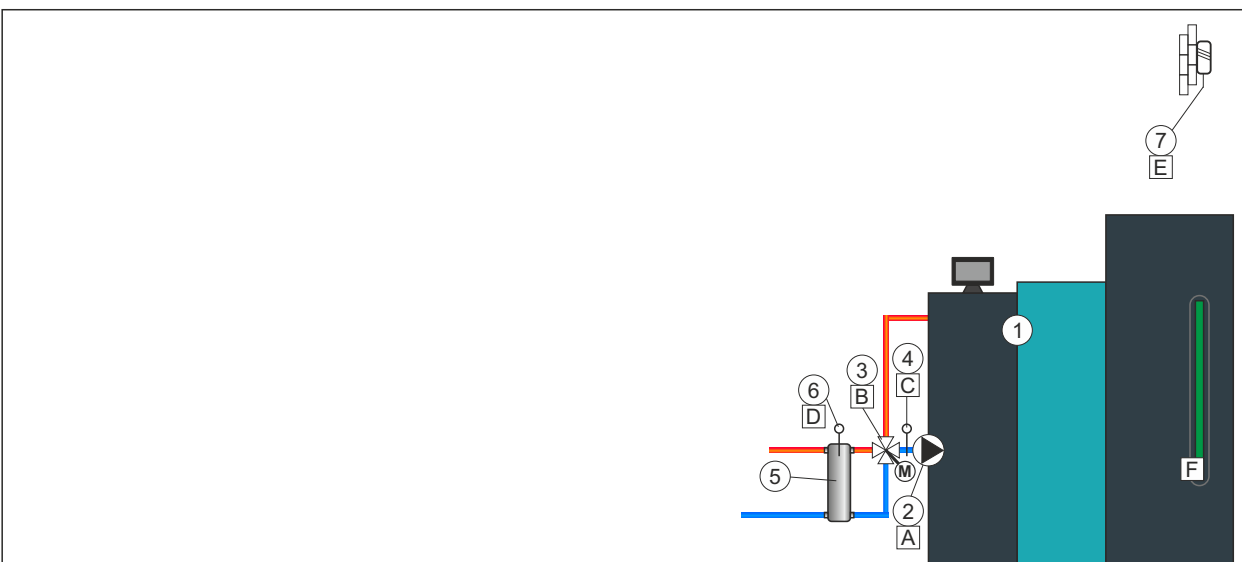

- 1 - Boiler PelTec II Lambda
- 2 - **P(PWM)** - (Boiler circuit)
- 3 - MIXING VALVE (4-way mixing valve with actuator - boiler circuit)
- 4 - Temperature sensor (boiler circuit - return flow)
- 5 - Hydraulic crossover
- 6 - Temperature sensor (Hydraulic crossover)
- 7 - Outdoor temperature sensor

Notes:

- in this configuration is possible to connect up to 3 unit "CM2K module for regulation 2 heating circuits".
- * in this configuration is possible to connect CSK-Touch (additional equipment) only if CM2K is installed.

A	P(PWM) to connectors
B	MIX VALVE to connector
C	S2 Return
D	S7 CRO
E	S8 Outdoor
F	CMSR +5V IN2 G
CSK-Touch	
*	CSKT
	+ -

5.0. ELECTRICAL CONNECTIONS

All electrical works must be performed by a certified professional in accordance with valid national and European standards. If the supply cord is damaged, it must be replaced by the manufacturer, its service agent or similarly qualified persons in order to avoid a hazard. A device for switching of all power supply poles must be installed in electrical installation in accordance with the national regulations on electrical installations. Pump of heating system should be connected to boiler control unit PelTec II Lambda.



CAUTION: When connecting any electrical part be sure to unplug the boiler at the main switch and disconnect the power supply.

Figure 4. Boiler control unit box (Switches, power connectors, cable grommets/glands)

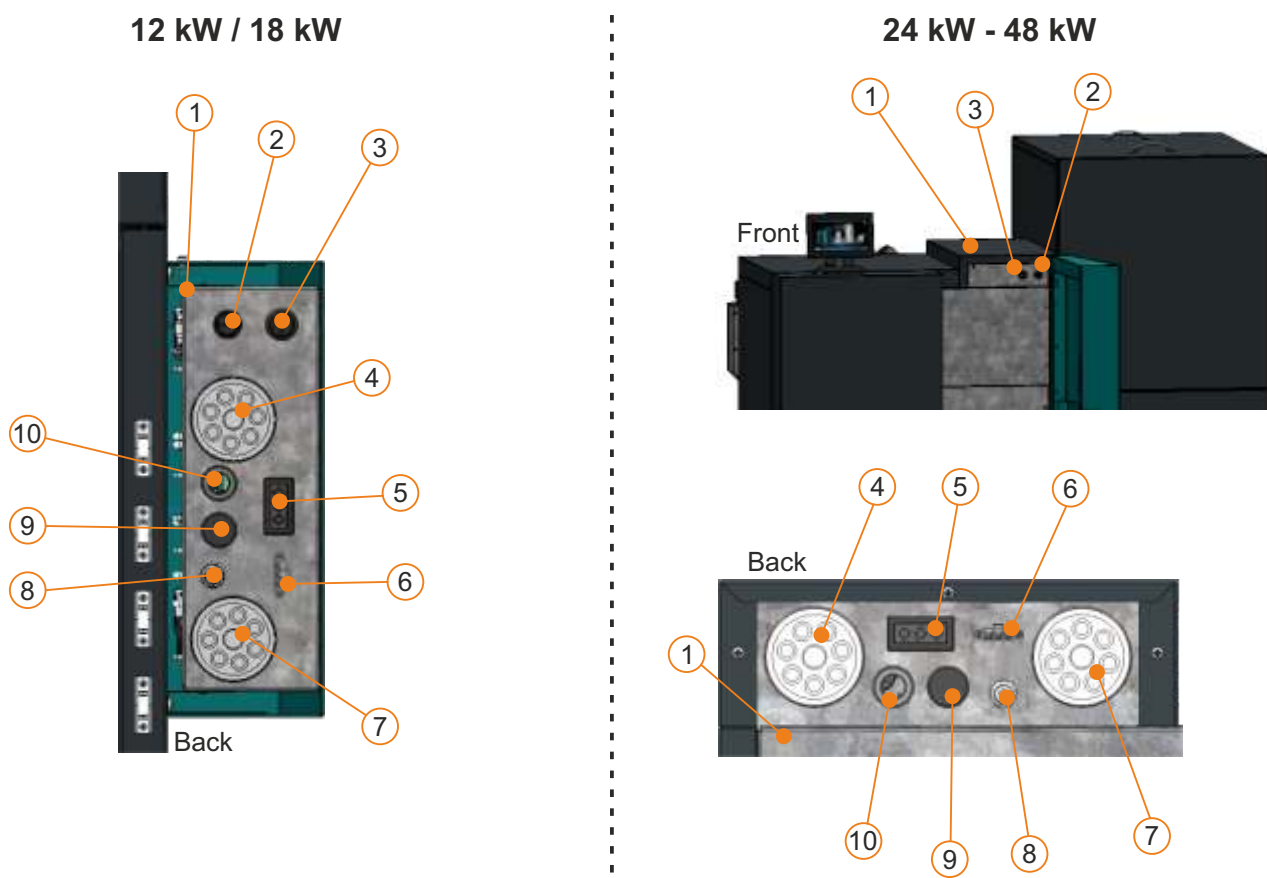

- 1 - Boiler control unit box
- 2 - Safety thermostat (STB)
- 3 - MAIN SWITCH (0/1)
- 4 - CABLE GROMMETS - Devices (230 V)
- 5 - Screw feeder
- 6 - Connector - Pellet level in the tank
- 7 - CABLE GROMMETS - Sensors/Room thermostat/Alarm (low-voltage or no-voltage conductors)
- 8 - CABLE GROMMETS - Guides for the lambda probe
- 9 - CABLE GROMMET - UTP cable (connection of additional equipment)
- 10 - CABLE GROMMETS - Fan

Figure 5. Connectors / cables with connectors that must be connected when installing the boiler.

① PWM (cable + connector) for connecting a PWM pump

② (cable + connector) 230 V for connection to the PWM pump

③ (cable + connector) for connection to the motor actuator of the 4-way mixing valve

④ (cable + connector) for connection to the fan

⑤ connector for connecting the screw feeder (on the boiler controller box)

6a - Cable holder - Boiler power supply 230 V, electric devices (230 V conductors) (installed by authorized technician only)

6b - Cable holder - Electric devices (230 V conductors) (factory installed/installed by authorized technician only)

6c - Cable holder - Sensors/Room thermostat/Alarm (low voltage or no voltage conductors) (installed by authorized technician only)

6d - Cable holder - Sensors/Room thermostat/Alarm (low voltage or no voltage conductors) (factory installed/installed by authorized technician only)

12kW / 18kW **24kW - 48kW**

Figure 6. Wiring on the rear side of the boiler

12 kW

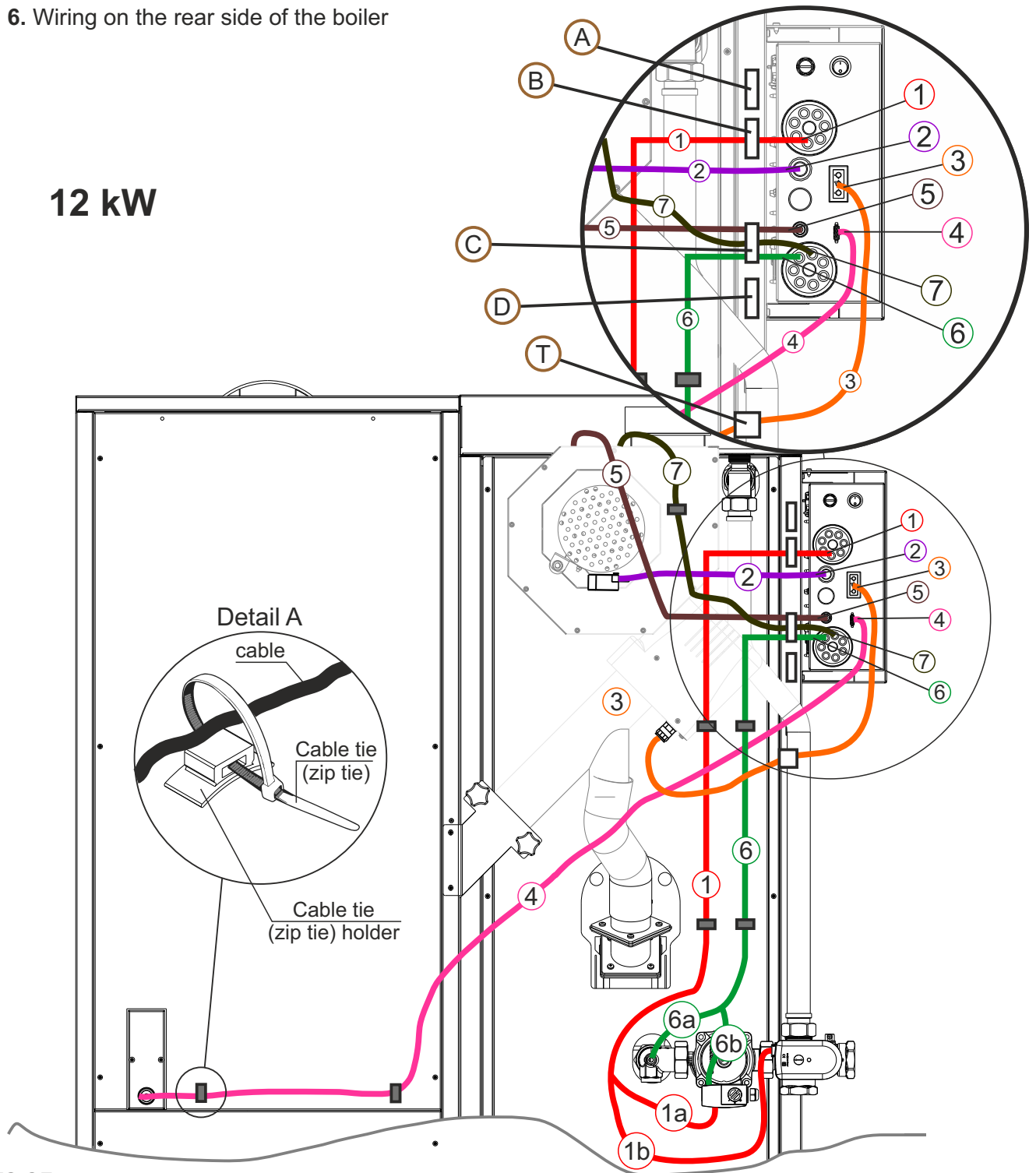

CABLES OF:

- 1a - PWM pump - 230 V cable || 1b - Actuator motor of the 4-way mixing valve || 2 - Fan ||
 3 - Screw feeder (transporter) || 4 - Pellet level sensor (installed by authorized technician only) || 5 - Lambda probe ||
 6a - Return flow (sensor) || 6b - PWM pump - PWM cable || 7 - Flue gas temperature sensor

CABLE HOLDERS:

- A - Cable holder - Boiler power supply 230 V, electric devices (230 V conductors) (installed by authorized technician only)
 B - Cable holder - Electric devices (230 V conductors) (factory installed/installed by authorized technician only)
 C - Cable holder - Sensors/Room thermostat/Alarm (low voltage or no voltage conductors) (installed by authorized technician only)
 D - Cable holder - Sensors/Room thermostat/Alarm (low voltage or no voltage conductors) (factory installed/installed by authorized technician only)
 T - Screw feeder (transporter) cable holder
 ■ - Cable tie (zip tie) (detail A)

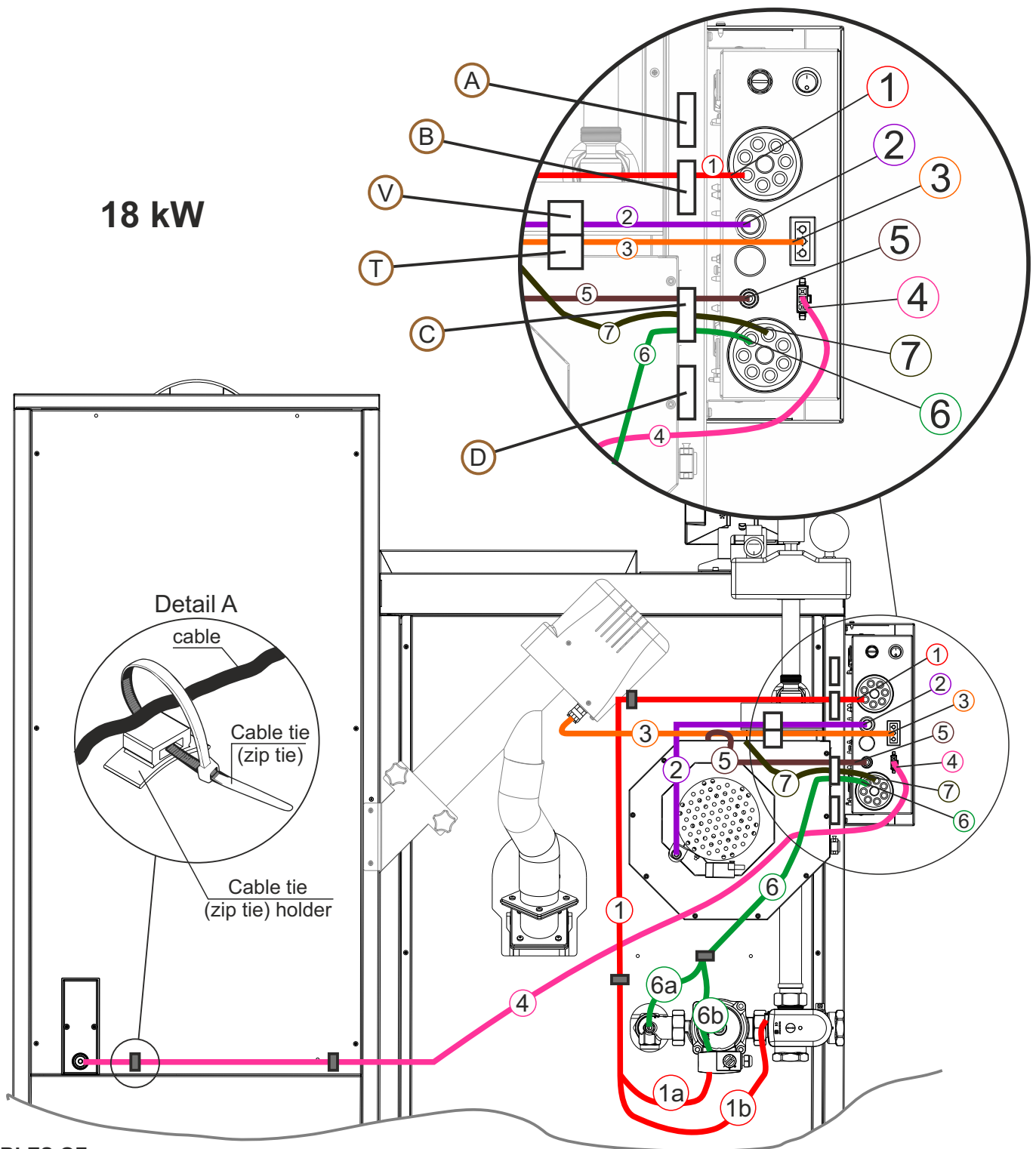

18 kW

CABLES OF:

1a - PWM pump - 230 V cable || **1b** - Actuator motor of the 4-way mixing valve || **2** - Fan ||
3 - Screw feeder (transporter) || **4** - Pellet level sensor (installed by authorized technician only) || **5** - Lambda probe ||
6a - Return flow (sensor) || **6b** - PWM pump - PWM cable || **7** - Flue gas temperature sensor

CABLE HOLDERS:

- A** - Cable holder - Boiler power supply 230 V, electric devices (230 V conductors) (installed by authorized technician only)
- B** - Cable holder - Electric devices (230 V conductors) (factory installed/installed by authorized technician only)
- C** - Cable holder - Sensors/Room thermostat/Alarm (low voltage or no voltage conductors) (installed by authorized technician only)
- D** - Cable holder - Sensors/Room thermostat/Alarm (low voltage or no voltage conductors) (factory installed/installed by authorized technician only)
- V** - Fan cable holder || **T** - Screw feeder (transporter) cable holder
- - Cable tie (zip tie) (detail A)

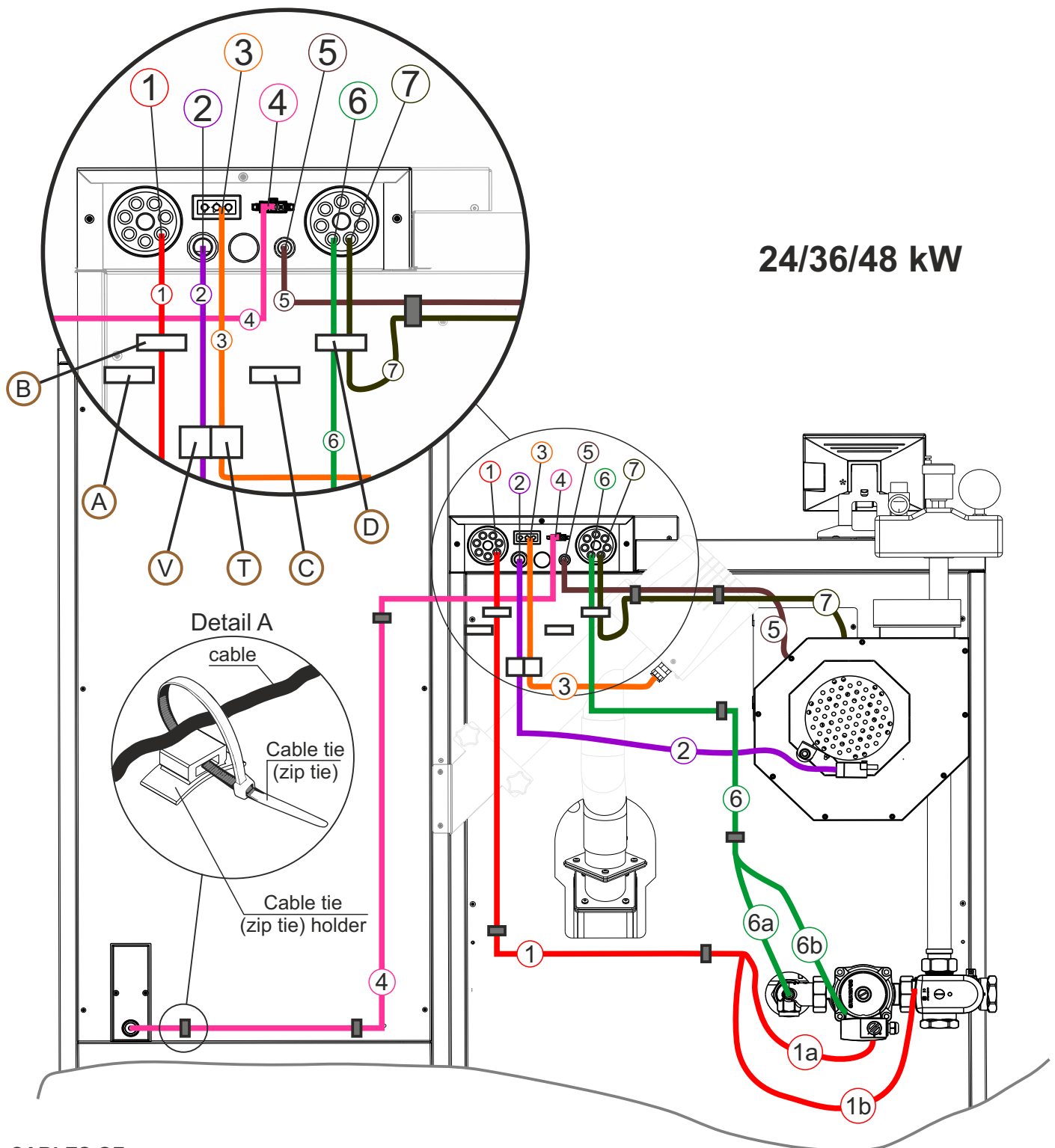

24/36/48 kW

- CABLES OF:**
1a - PWM pump - 230 V cable || **1b** - Actuator motor of the 4-way mixing valve || **2** - Fan ||
3 - Screw feeder (transporter) || **4** - Pellet level sensor (installed by authorized technician only) || **5** - Lambda probe ||
6a - Return flow (sensor) || **6b** - PWM pump - PWM cable || **7** - Flue gas temperature sensor

- CABLE HOLDERS:**
A - Cable holder - Boiler power supply 230 V, electric devices (230 V conductors) (installed by authorized technician only)
B - Cable holder - Electric devices (230 V conductors) (factory installed/installed by authorized technician only)
C - Cable holder - Sensors/Room thermostat/Alarm (low voltage or no voltage conductors) (installed by authorized technician only)
D - Cable holder - Sensors/Room thermostat/Alarm (low voltage or no voltage conductors) (factory installed/installed by authorized technician only)
V - Fan cable holder || **T** - Screw feeder (transporter) cable holder
■ - Cable tie (zip tie) (detail A)

Figure 7. Fixing the cables in the controller box



All input/output cables (230 V and low voltage) must be fastened in the "Place for fixing of input/output cables".

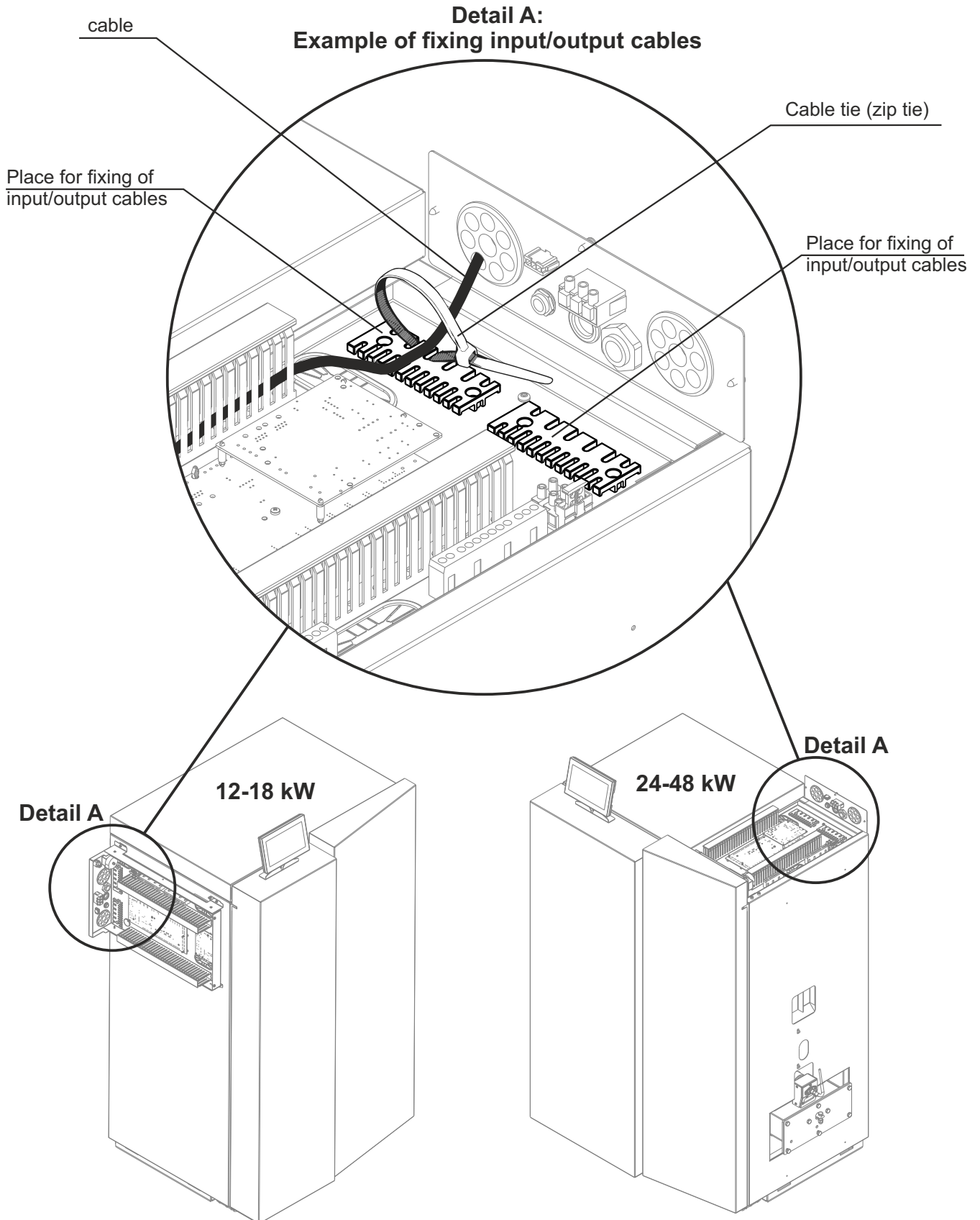
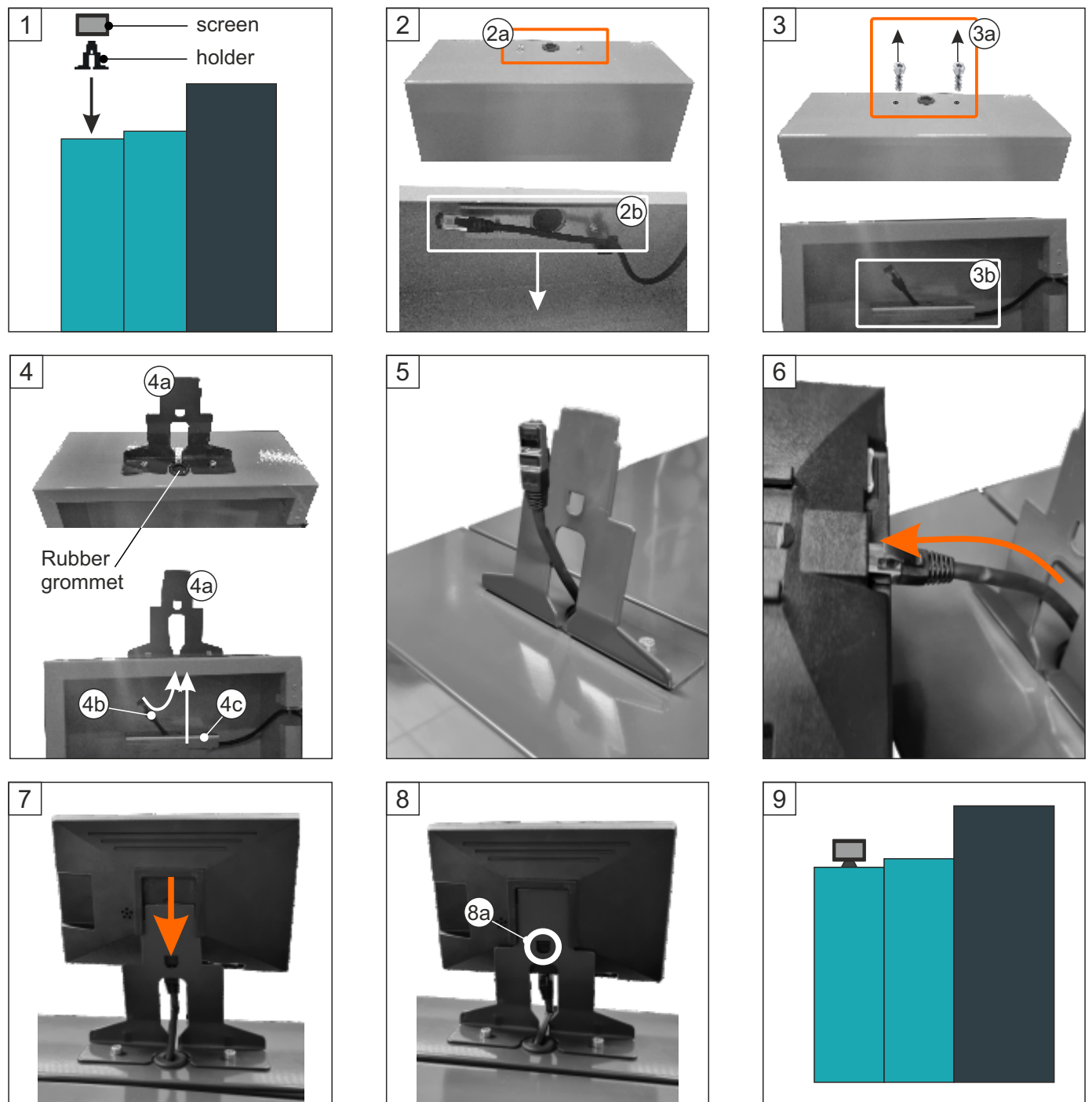

Figure 8. Holder and boiler control unit screen installation (7") (18-48kW)



1. The place where the *holder* with the *screen* should be mounted.
2. It is necessary to unscrew the two screws (2a) which hold the metal plate and the UTP cable (2b).
3. Step 3 shows the state after removing the screws (3a). The metal plate and the UTP cable (3b) will be separate.
4. Place the *holder* in the intended location (4a). Pass the UTP cable (4b) through the rubber cable gland and screw the holder (4a) and metal plate (4c) together, using two screws (3a).
5. Screen *holder* and UTP cable after installation.
6. Connect the UTP cable to the *screen*.
7. Place the *screen* on the *holder* and pull it down.
8. Pull the *screen* down, until the marked part of the plastic fits into the slot (8a).
9. Boiler state with *holder* and *screen*.

5.1. FUSES

Main PCB: UniDrive

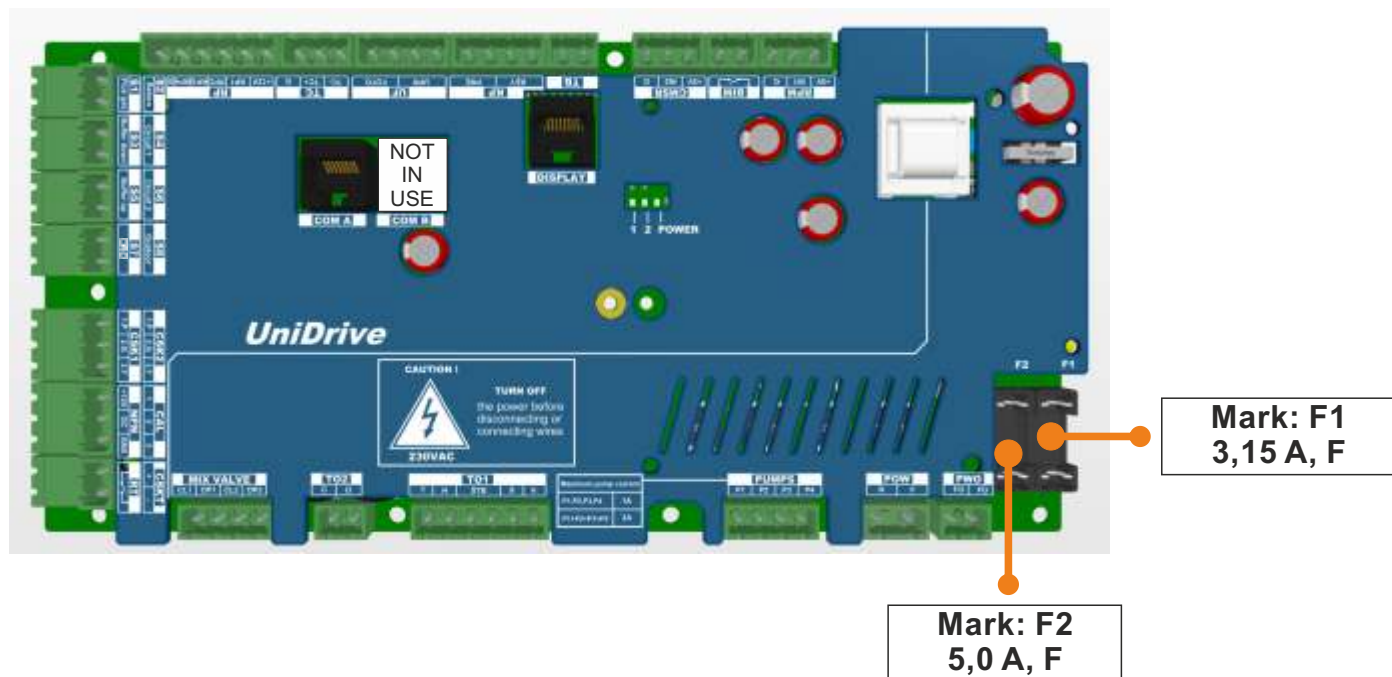

Lambda probe PCB: LC-21-GS V1 (22995XXXXXXX "G")

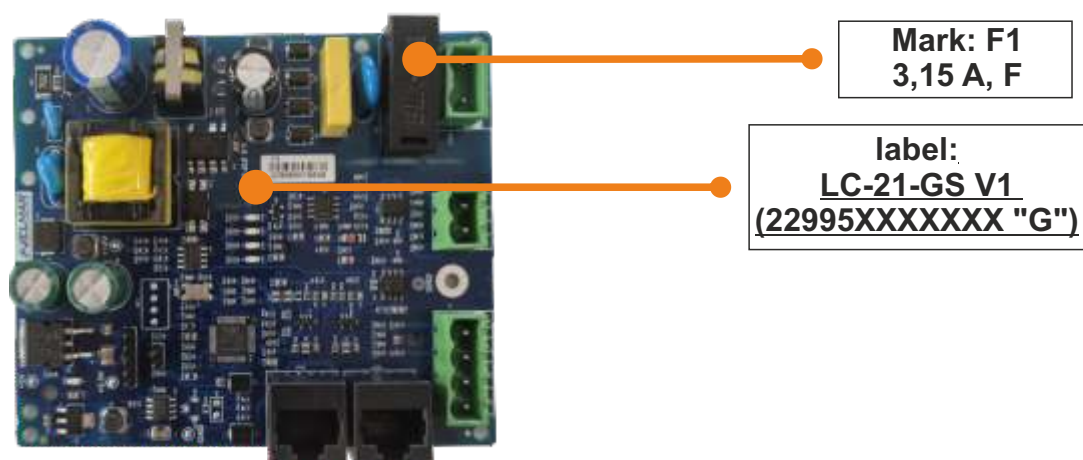

Control unit box: main fuse



Fuses

Main PCB: UniDrive

MARK	FUSE	DEVICES
F1	3,15 A, F	- Pumps P1, P2, P3, P4 (total max = 3 A) - UniDrive PCB power supply
F2	5,0 A, F	- Turbulators motor - Electric heater - Flue gas fan (with RPM sensor) - Mixing valve (boiler circuit) - Grate cleaning mechanism motor - P(PWM) - (Boiler circuit) - Pellet feeder motor - Mixing valve 1

Lambda probe PCB: LC-21-GS V1 (22995XXXXXX "G")

MARK	FUSE	DEVICES
F1	3,15 A, F	- Lambda probe (power supply)

Control unit box: main fuse

MARK	FUSE	DEVICES
F1	6,3 A, M	- Main fuse (all devices and PCB on the boiler)

Note:

Acting fuses:

M = Medium Acting Fuse (Mitteltrage)

F = Fast Acting Fuse (Flink)



IMPORTANT: When replacing a fuse, be sure turn **OFF** the boiler at the main switch and unplug the power cord.

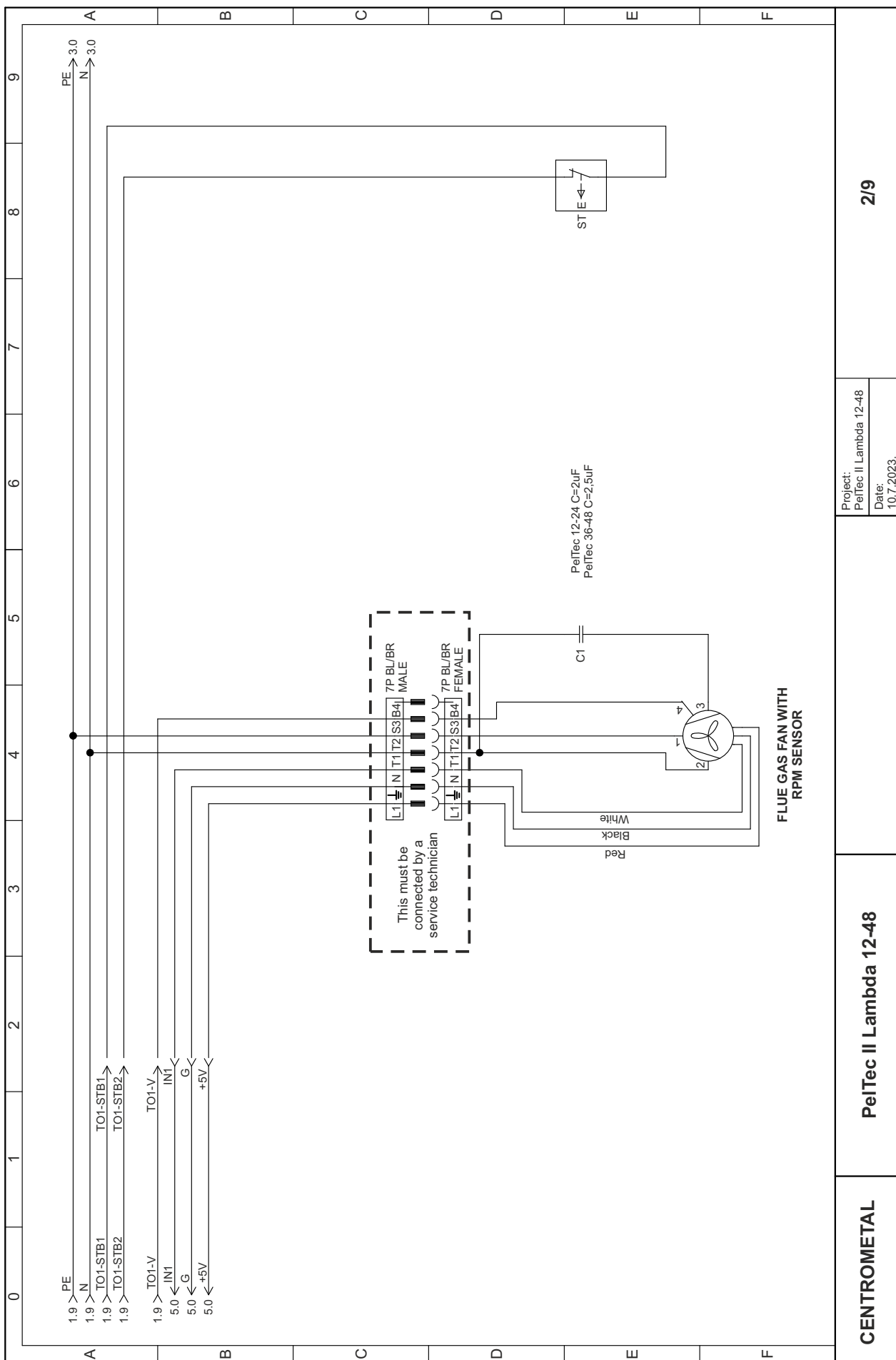

Project:
PeITec II Lambda 12-48
Date:
10.7.2023.

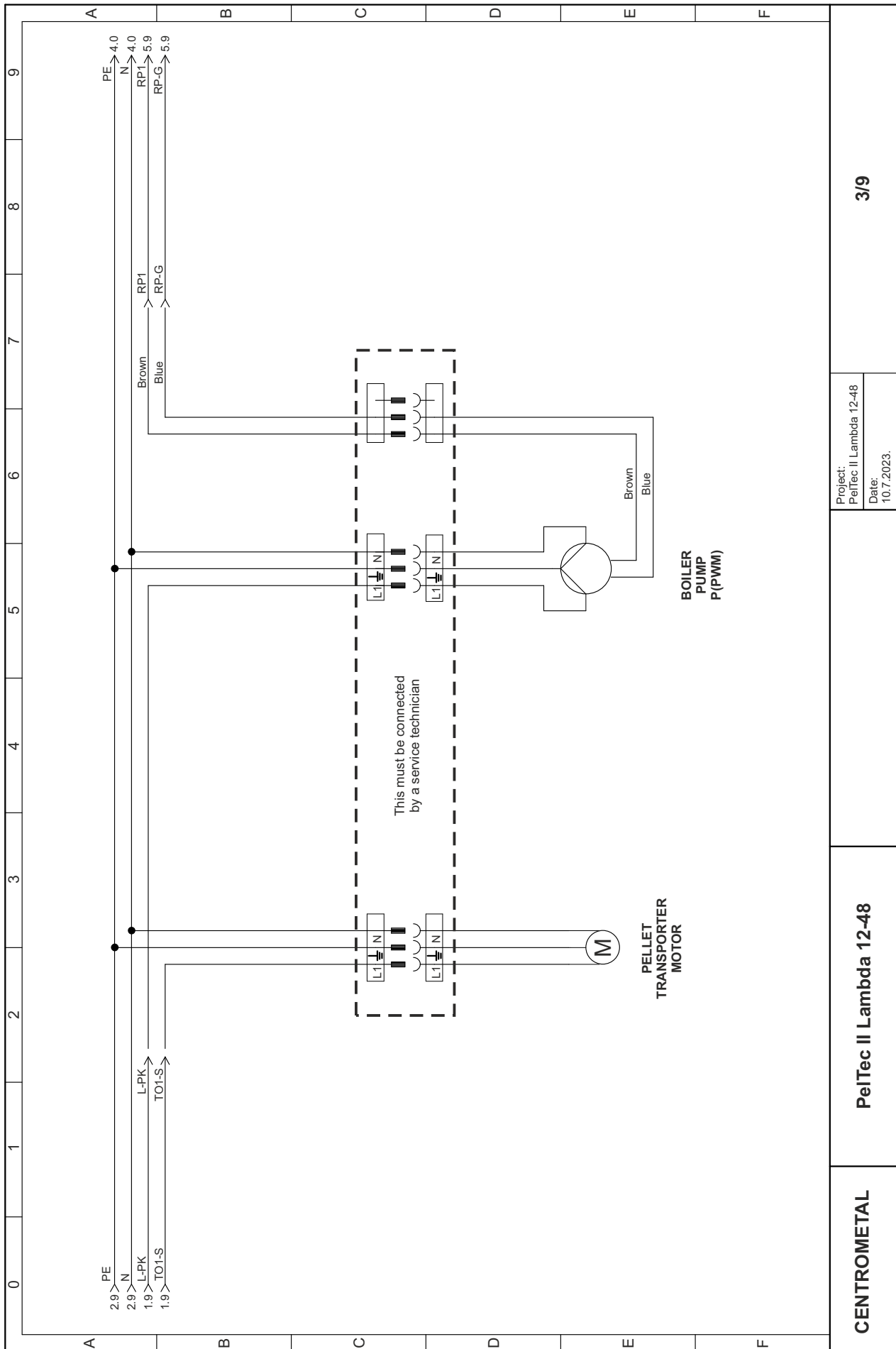

Project:
PeITec II Lambda 12-48
Date:
10.7.2023.

3/9

PeITec II Lambda 12-48

CENTROMETAL

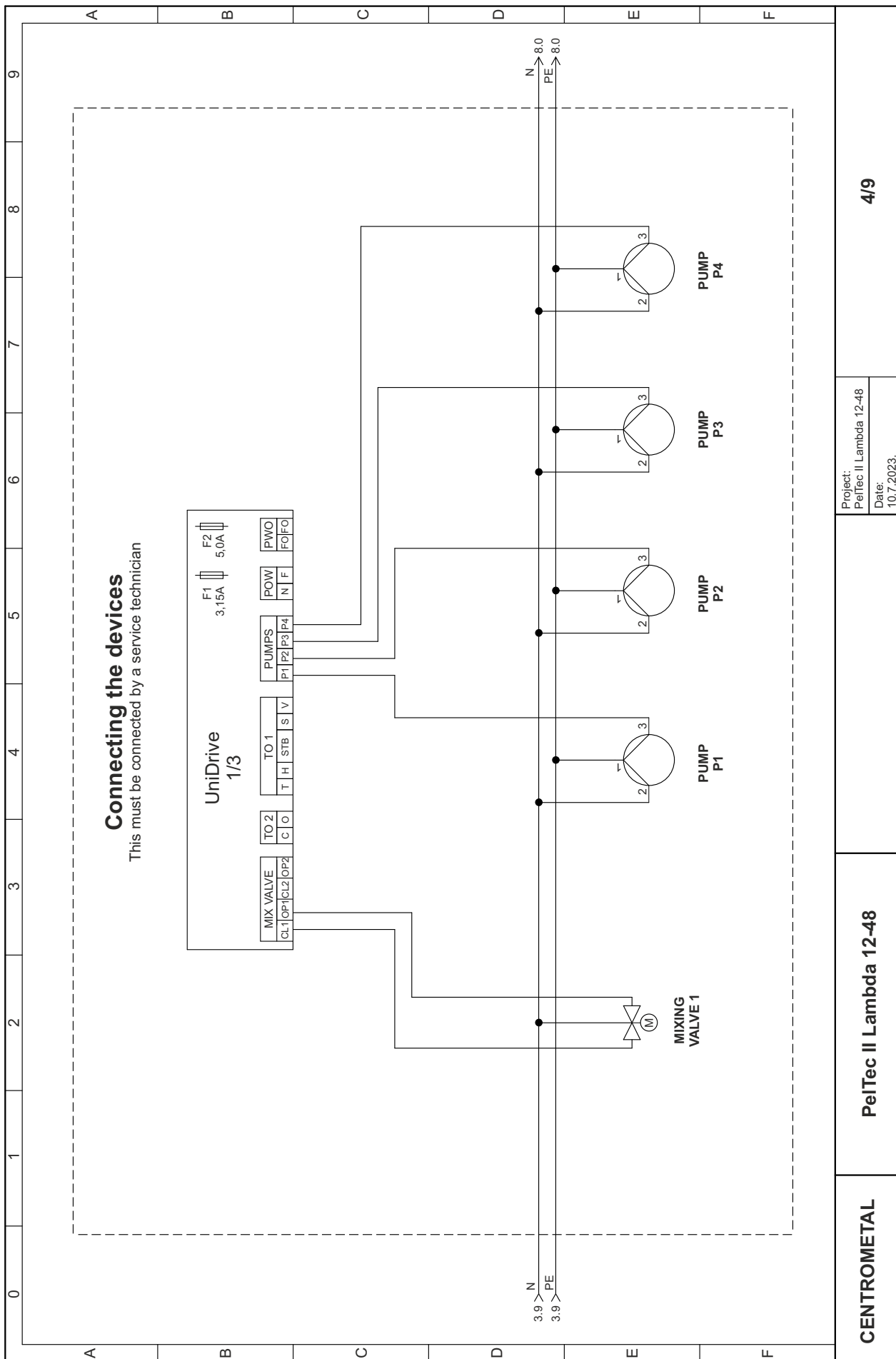

Project: PeITec II Lambda 12-48
Date: 10.7.2023.

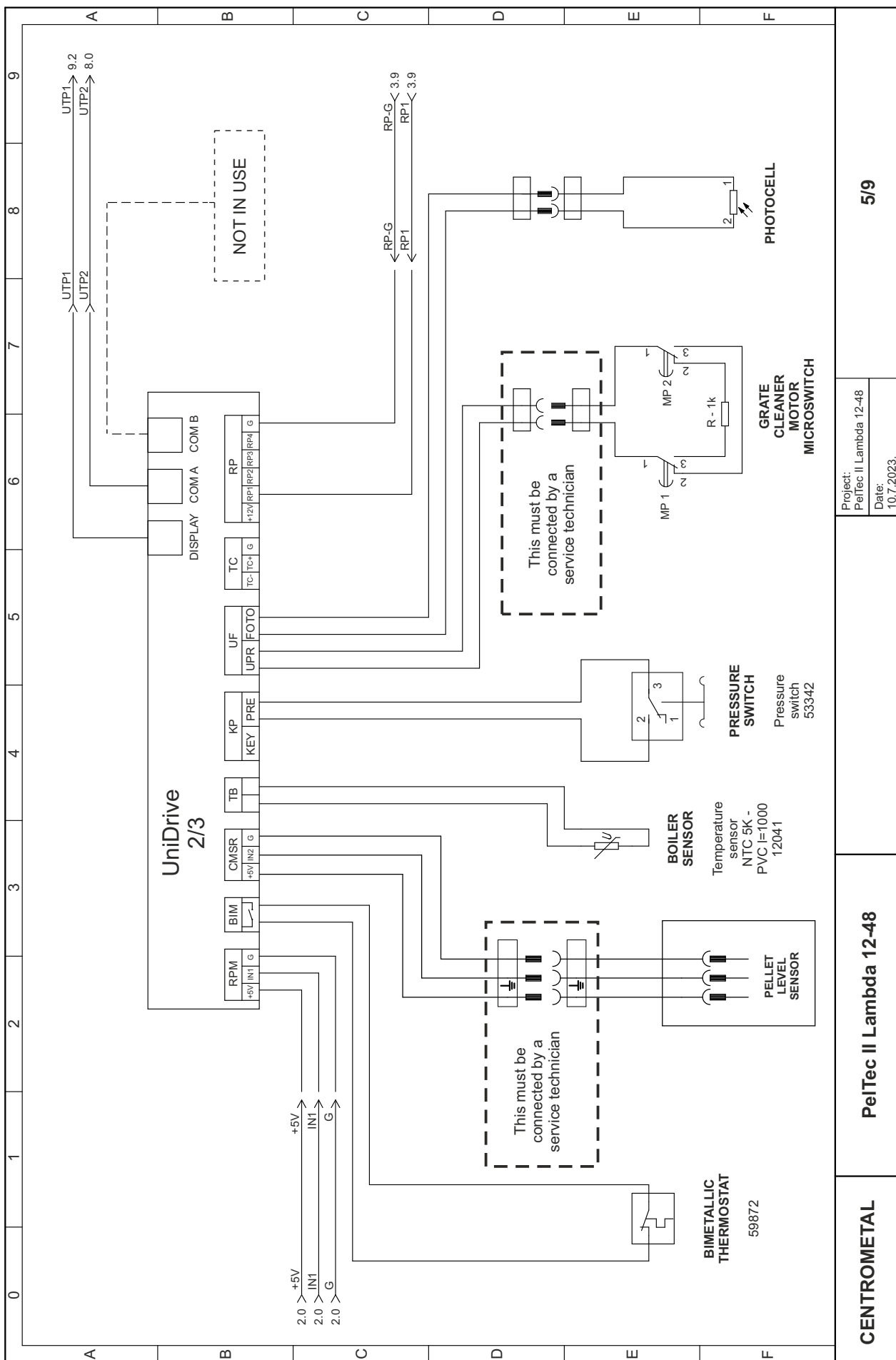

Project: PelTec II Lambda 12-48
Date: 10.7.2023.

5/9

PelTec II Lambda 12-48

CENTROMETAL

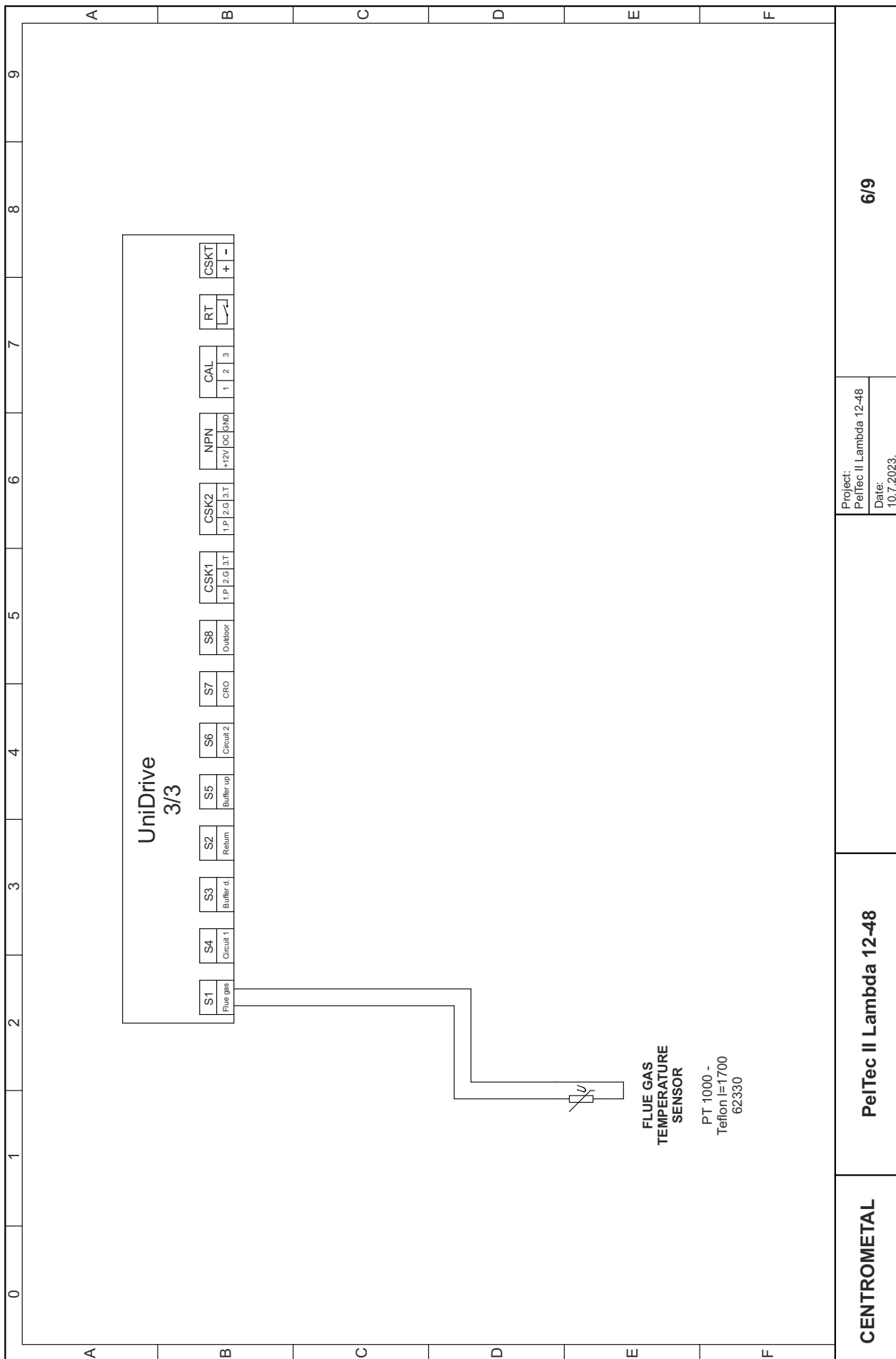

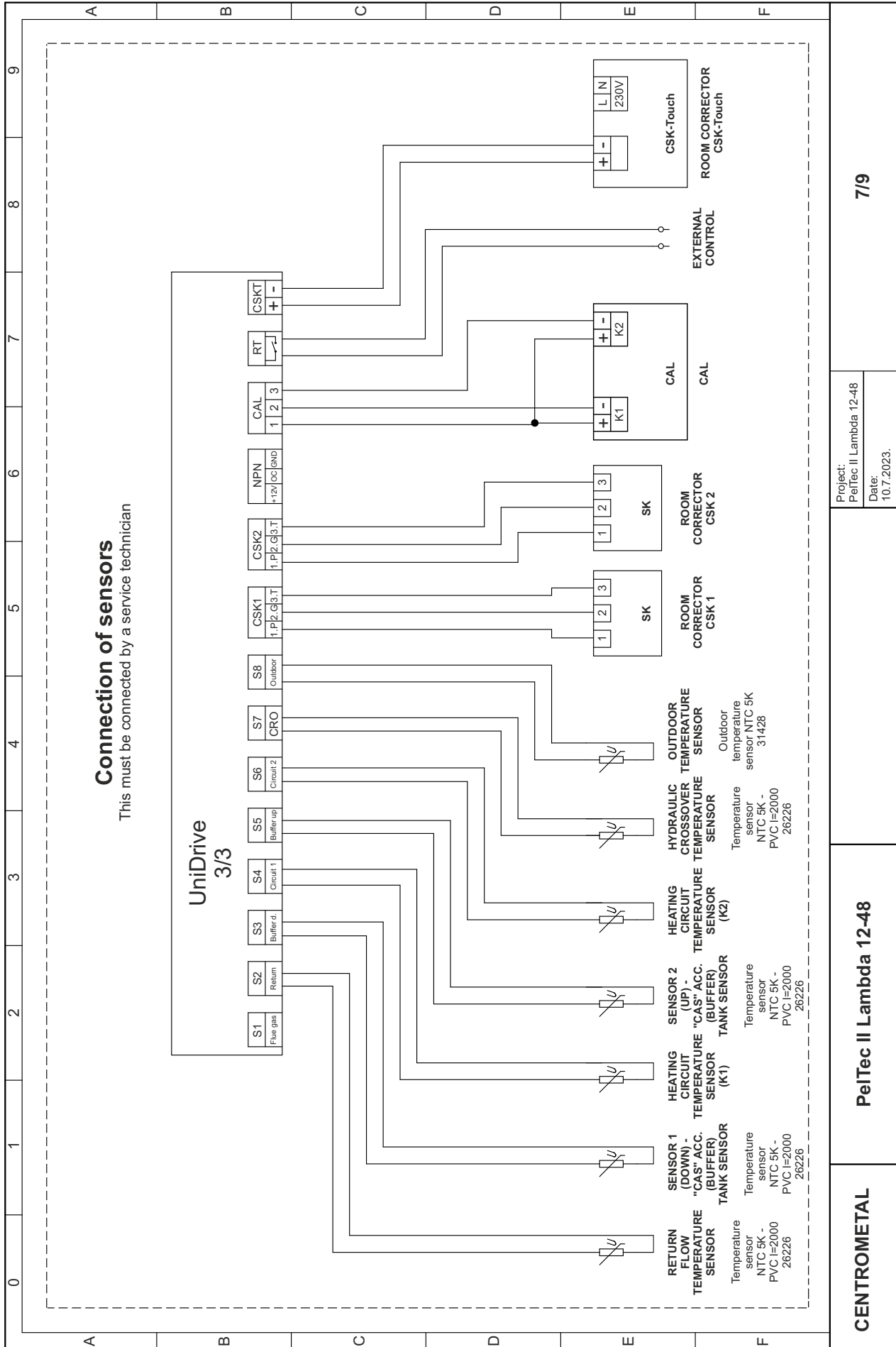

Project: PeITec II Lambda 12-48
Date: 10.7.2023.

7/9

PeITec II Lambda 12-48

CENTROMETAL

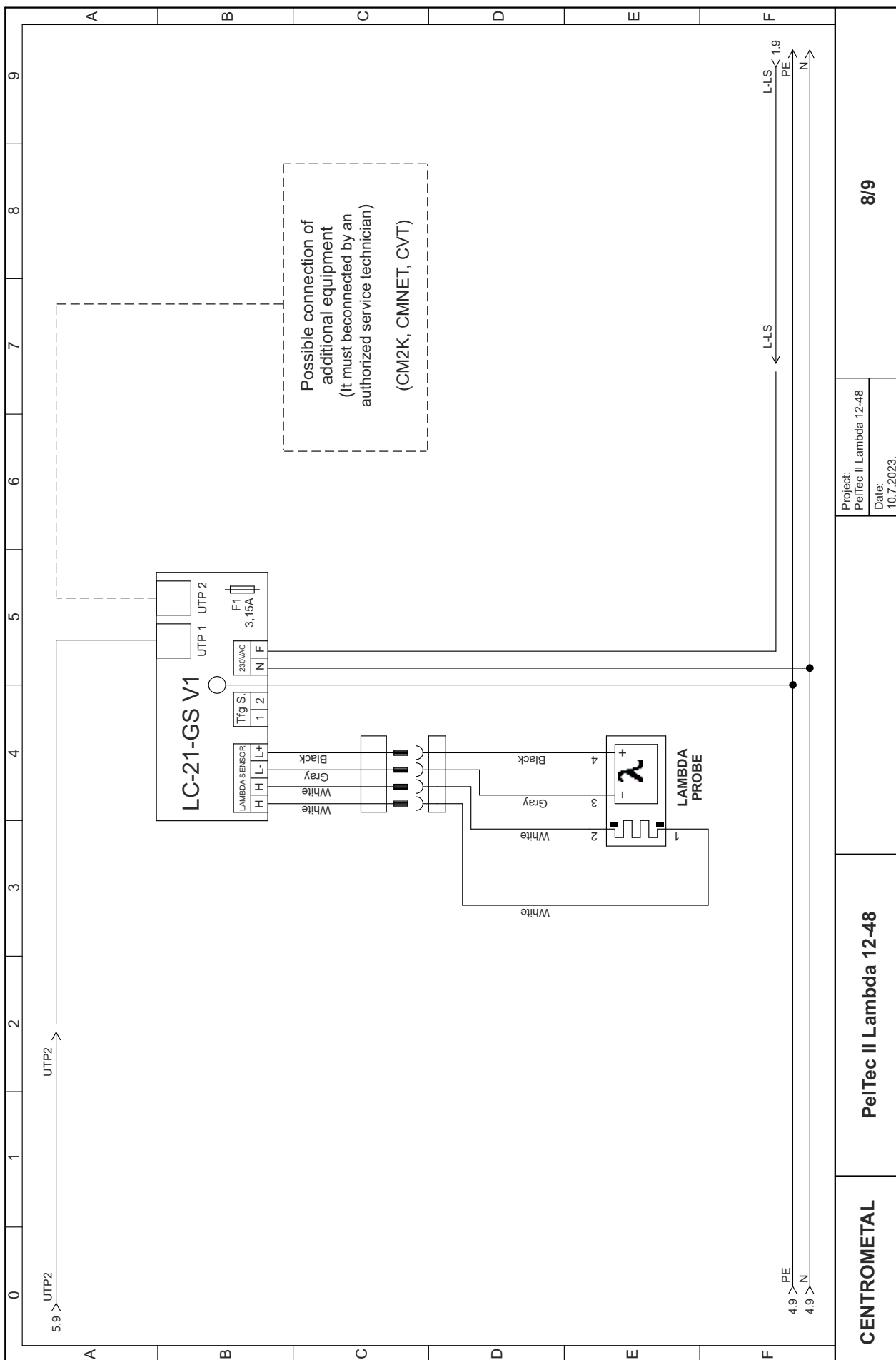

Project:
PeITec II Lambda 12-48
Date:
10.7.2023.

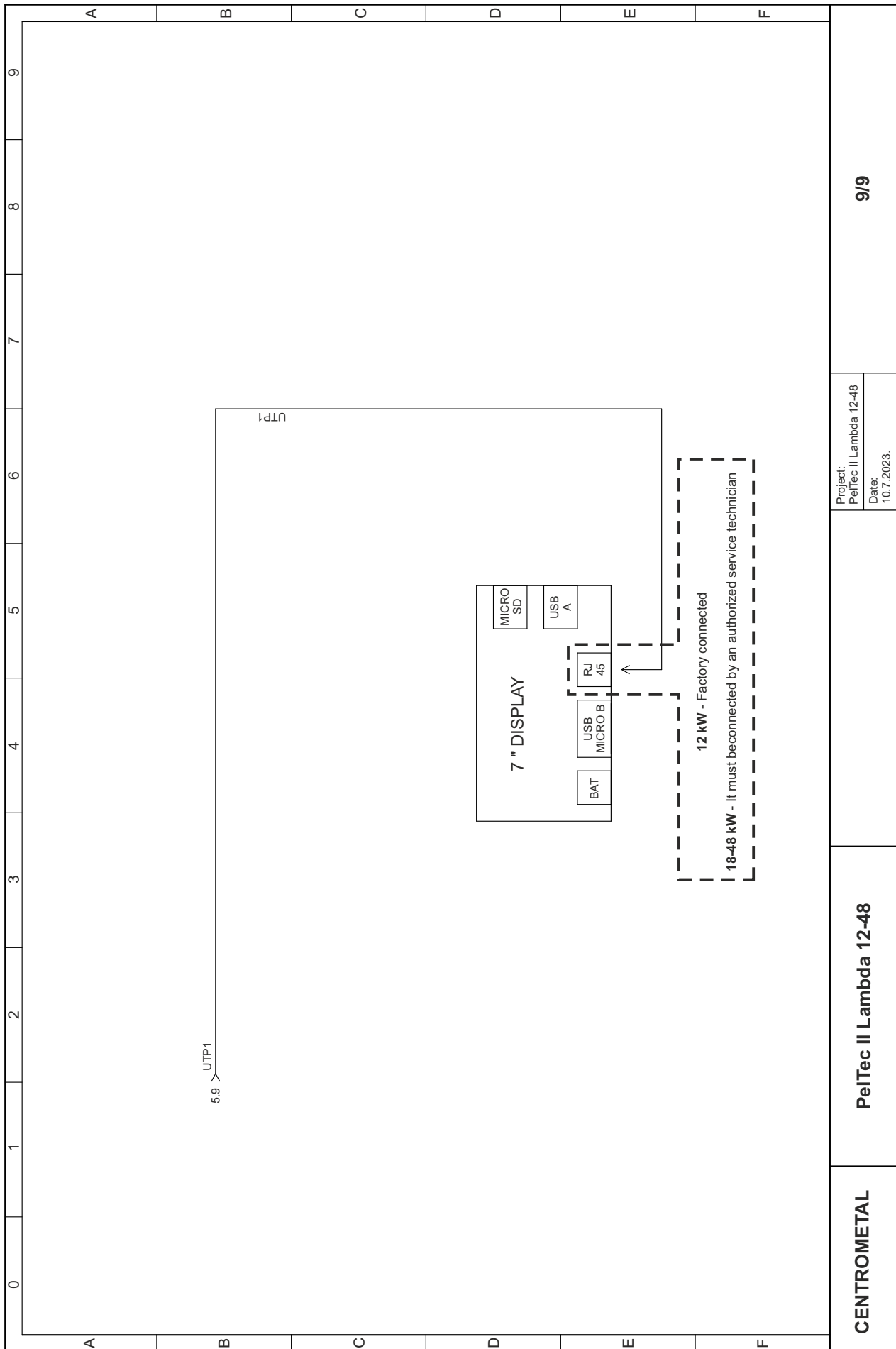

6.0. OPERATING THE SYSTEM

Boiler must not be used in flammable and explosive environment.

It must not be used by children or disabled persons (either physically or mentally), as well as by person without knowledge or experience, unless they are under control or trained by a person responsible for their safety.

Children must be supervised in the vicinity of the product. If the supply cord is damaged, it must be replaced by the manufacturer, service technician or similarly qualified person.

6.1. SAFETY INSTRUCTIONS FOR THE INSTALLATION ROOM

Boiler room must be frost-proof and well ventilated. Boiler has to be positioned so that it can be properly connected to the chimney and simultaneously, enabling tending of boiler and additional equipment, control during operation, and cleaning and maintenance.

6.2. INITIAL STARTUP

See technical instructions for PelTec II Lambda digital controller where is explained initial startup.

Note:

The start up has to be done by the authorized person, otherwise the warranty for this product is not valid and the product must not be used.

Note:

If condensation escapes during the initial heatup phase, this does not indicate a fault. If this occurs, clean up using a cleaning rag.

6.3. FILLING / REFILLING PELLET STORAGE WITH FUEL



Use only permitted pellets (see point 1.7 of this technical manual)!

6.3.1. BOILER USE



The heating system should be vented if necessary so that water can circulate normally through the system. To airvent the heating installation, use the "AIRVENT" option (see technical instructions PelTec II Lambda_CONTROLLER).

Boiler must not be used in flammable and explosive environment.

It must not be used by children or disabled persons (either physically or mentally), as well as by person without knowledge or experience, unless they are under control or trained by a person responsible for their safety. Children must be supervised in the vicinity of the product. If the supply cord is damaged, it must be replaced by the manufacturer, its service agent or similarly qualified persons in order to avoid a hazard. Protective gloves are obligatory.

Check whether boiler and equipment are installed and connected in accordance with these Technical instructions. Check whether chimney meets requirements of point 3.0 therein. Check whether boiler room meets all requirements therein. Check if fuel fulfils all requirements therein. Check whether the boiler and the entire heating system are filled with water and vented.

Note:

Before every use check if the boiler doors and cover door are closed (Figure 9).

If you smell flue gas:

- Shut down the heating system
- Ventilate the boiler room
- Close all doors leading to the living space



Flue gas can lead to life-threatening poisoning!

Figure 9. PelTec II Lambda boiler doors

Upper boiler door

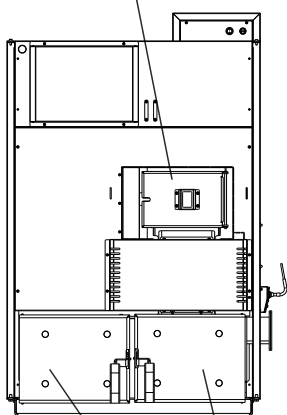

Lower left boiler door
(Behind the door
is a ashbox)

Lower right boiler door
(Behind the door
is a ashbox)

Turbulators of
flue gas tubes

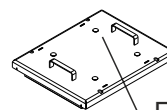

Flue gas tubes door
(12-48)

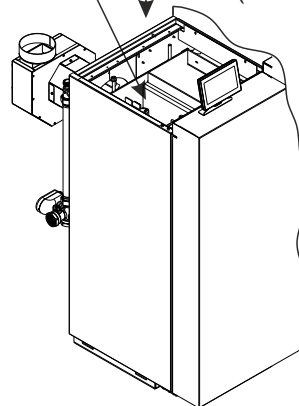

If for any reason the screw feeder is empty, it must be filled with pellets before starting the boiler with the option "FILLING FEEDER SCREW" (see technical instructions PelTec II Lambda_CONTROLLER).

7.0. CLEANING AND MAINTENANCE

Every millimeter of soot on the exchange surfaces and in the flues means about 5 % more fuel consumption. A clean boiler saves fuel and protects the environment.

Save fuel – always clean the boiler in good time!

PROTECTIVE GLOVES ARE OBLIGATORY!



Cleaning interval	Boiler type	Description
After spent 150-250 kg of pellets	12kW	Discharge ash boxes
After spent 250-350 kg of pellets	18kW	Discharge ash boxes
After spent 300-450 kg of pellets	24kW	Discharge ash boxes
After spent 400-600 kg of pellets	36/48kW	Discharge ash boxes

Emptying the ash box:

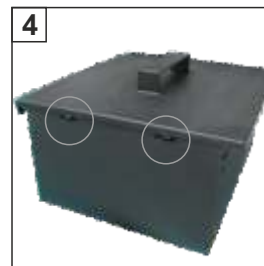
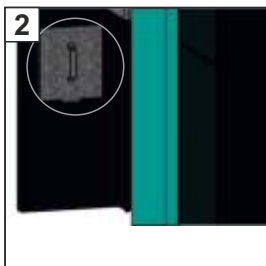

1. Take out ash boxes (12 kW = 1x, 18-48 = 2x).
2. For carrying ash boxes, use a protective cover which is located on the inside of front door. For boilers 18-48 kW take out one by one box in order to use the same cover (Figure 2).
3. Attach the cover to the 3 holes (Figure 3.4) .
4. Put the cover and ash box back to original position.

IMPORTANT! The ash can be disposed only in a metal container!

Cleaning interval	Boiler type	Description
At least once per year (This procedure is very simple and is recommends even more often)	12-48 kW	Cleaning of exchanging surfaces (above the burner)

Claning of exchanging surfaces (above the burner)

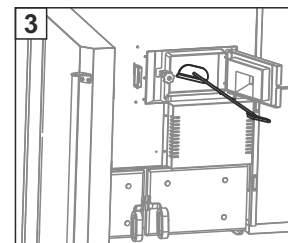
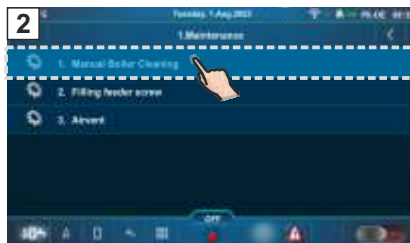
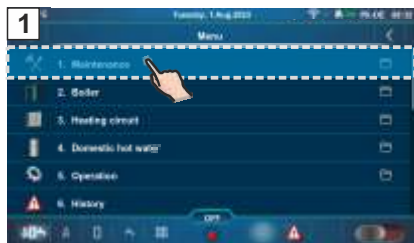

- 1 - Press the "Maintenance" on the regulation and then "Manual Boiler Cleaning".
- 2 - Press the "ON" button with the desired fan speed (it will start the fan and it will open a grate.)
- 3 - By using scraper, brush or vacuum cleaner, through the door clean exchanging surfaces
- 4 - After you finish cleaning, press "back" (⬅) on regulation to control the boiler back to normal mode and close the combustion chamber door.

Cleaning interval	Boiler type	Description
When needed	12-48 kW	Cleaning the blades and box of the fan

Cleaning the blades and box of the fan

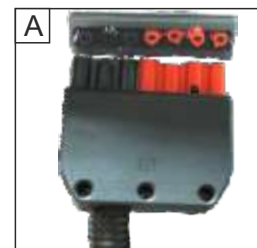
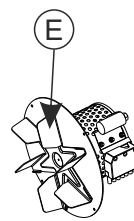
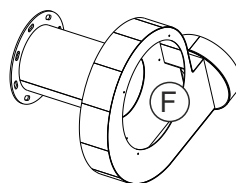
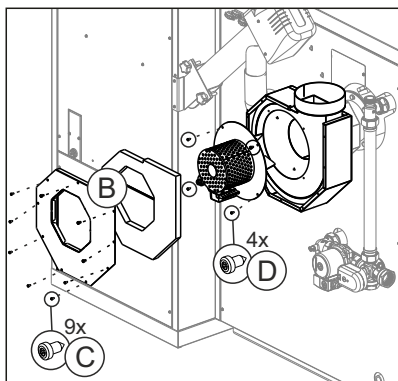

1. Switch off the boiler and disconnect from electric power.
2. Pull out the 7-pole connector (A) from the fan connection.
3. Remove the cover lid and the insulation (B) which are secured with 9 screws (C).
4. Unscrew the 4 screws (D) and remove the fan, clean the fan blades (E), check the condition of the fan box (F) and clean if necessary with a vacuum cleaner or remove from the boiler and clean completely.
5. Set back the fan into original position and secure it with screws, then connect 7-pole connector (A) to the connection on the fan and connect the power supply to the boiler.

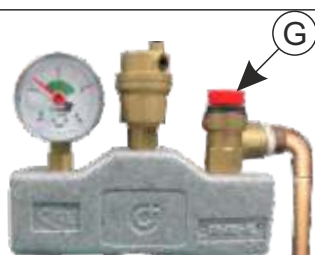

Cleaning interval	Boiler type	Description
Every 6 months	12-48 kW	Check the correctness of safety valve



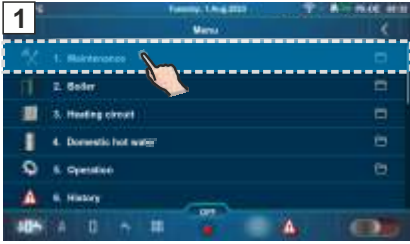
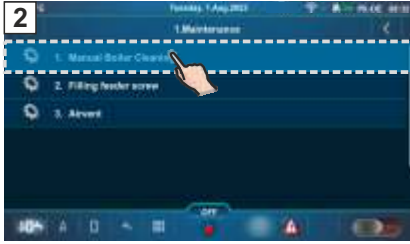
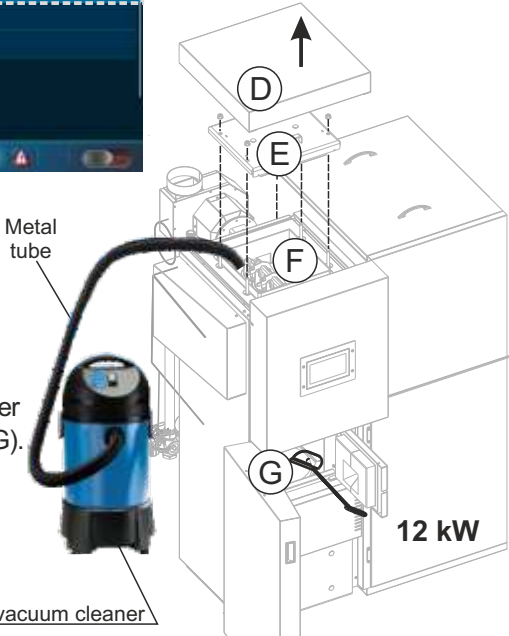

Checking the correctness of safety valve

By briefly turning the cap of safety valve (G) check whether water coming out from the safety valve. If no water comes out after several repeated checks, then is necessary to replace the safety valve.

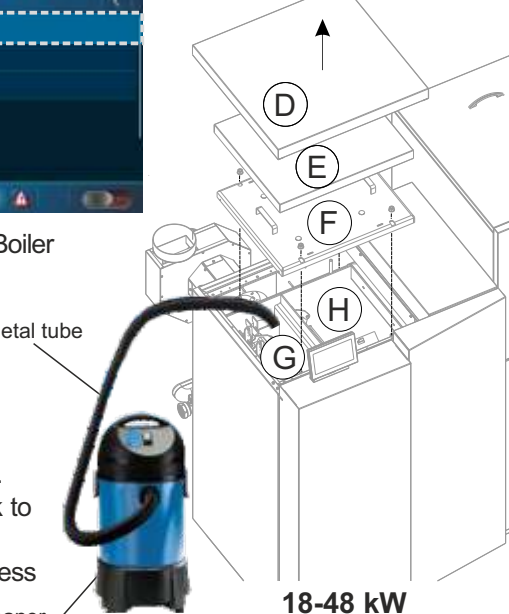
Cleaning interval	Boiler type	Description
At least once per year	12 kW	Cleaning of exchanging surfaces (around the entire boiler)
<div style="display: flex; justify-content: space-between;"> <div style="width: 30%;">  <p>1</p> </div> <div style="width: 30%;">  <p>2</p> </div> <div style="width: 35%;">  </div> </div> <ol style="list-style-type: none"> 1. Press the "Maintenance" on the regulation and then "Manual Boiler Cleaning". 2. Press the "ON" button with the desired fan speed (it will start the fan and it will open a grate.) 3. Lift the top cover (D), then unscrew the four screws and remove the upper door (E). 4. By using scraper, brush and vacuum cleaner, through the upper side and trough the front door clean exchanging surfaces (F, G). 5. When you have finished cleaning, set upper door back to original position and tighten them well, then set the top cover back to position and close the front door of the boiler. Then press "back" on the controller (⬅) to return boiler to normal mode. 		

Cleaning interval	Boiler type	Description
At least once per year	18-48 kW	Cleaning of exchanging surfaces (around the entire boiler)
<div style="display: flex; justify-content: space-between;"> <div style="width: 30%;">  <p>1</p> </div> <div style="width: 30%;">  <p>2</p> </div> <div style="width: 35%;">  </div> </div> <ol style="list-style-type: none"> 1. Press the "Maintenance" on the regulation and then "Manual Boiler Cleaning". 2. Press the "ON" button with the desired fan speed (it will start the fan and it will open a grate.) 3. Remove the top cover (D) and cover (E), then unscrew the 4 screws and remove the cover (F). 4. Clean the flue gas passages and exchanger using a vacuum cleaner, brush and scraper starting from the upper part (G, H). 5. When you have finished cleaning, set upper door (cover) back to original position and tighten them well, then set the top cover back to position and close the front door of the boiler. Then press "back" on the controller (⬅) to return boiler to normal mode. 		

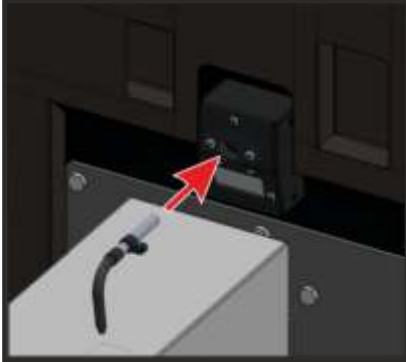
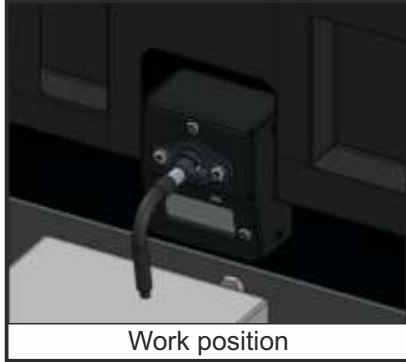
Photocell cleaning interval	Boiler type	Description
At least once a year (or if you have problems with the ignition)	12-48 kW	Photocell cleaning
<div style="display: flex; justify-content: space-around; align-items: center;"> <div style="text-align: center;">  <p>Dirty photocell which can result error in ignition or flame dissapear error</p> </div> <div style="text-align: center;">  <p>Valid photocell</p> </div> </div> <p>Carefully remove the photocell from the box and then gently with a cotton swab clean the body and lens of photocell. After cleaning, carefully return photocell to work position.</p> <div style="display: flex; justify-content: space-around;"> <div style="text-align: center;">  </div> <div style="text-align: center;">  <p>Work position</p> </div> </div>		

Cleaning interval	Boiler type	Description
At least once per year	12-48 kW	Cleaning and checking the flue installation sealing
<p>Cleaning and checking the flue installation sealing</p> <p>Clean flue installation between the boiler and the chimney through the revision openings for cleaning or if not incorporated revision opened by removing the flue installation. After cleaning, inspect flue installation good sealing and seal it if the seal is not satisfactory.</p>		



The ecological rules and standards must be applied for disposal of changed spare parts, wrapping material, all parts of the boiler after it's expire.

1. Electric heater
2. Failure on distribution power box with digital boiler control unit
3. Fan failure
4. Pellet feeder Motor failure
5. Temperature sensors failure
6. Photocell failure

Every seven years to call an authorized service provider for routine maintenance and control.

7.1. EXTRACTION OF TURBULATORS - PeITec II Lambda 12-48

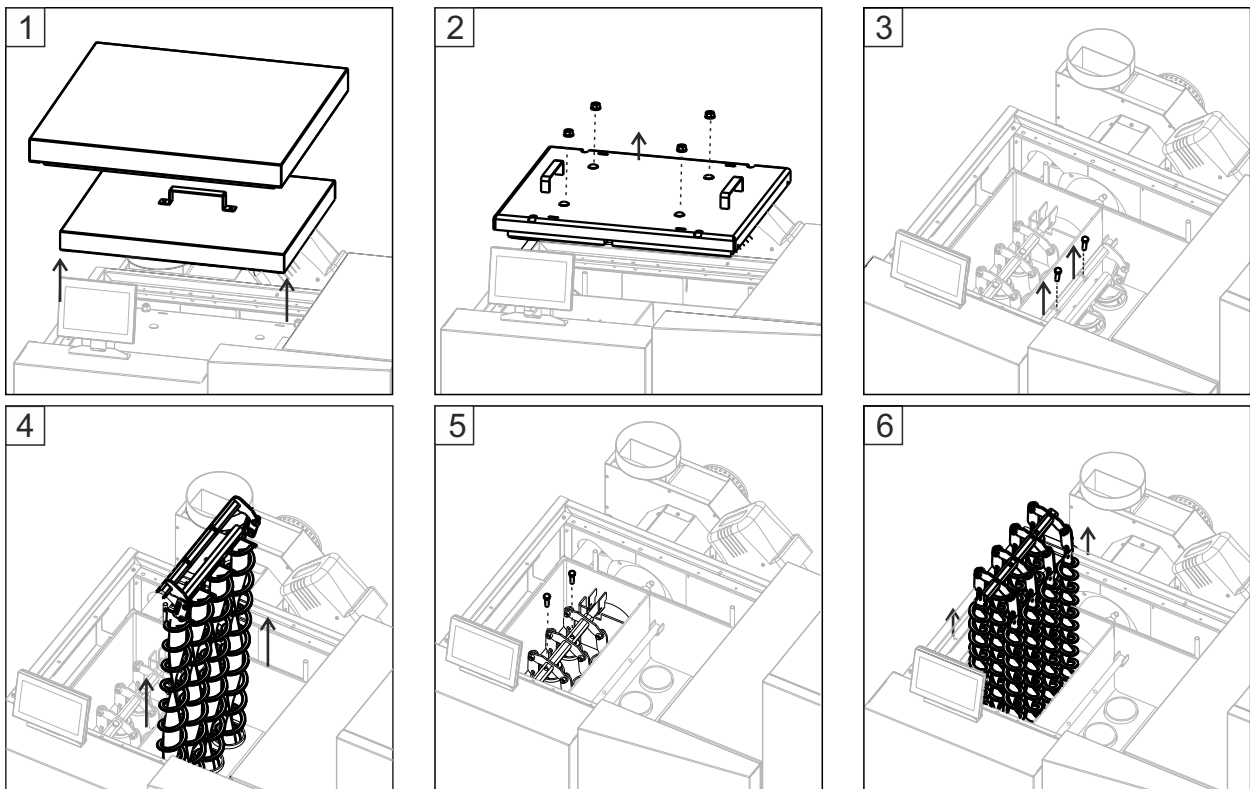

6.a i 6.b Only in case all turbulators can't be removed together (step 6)

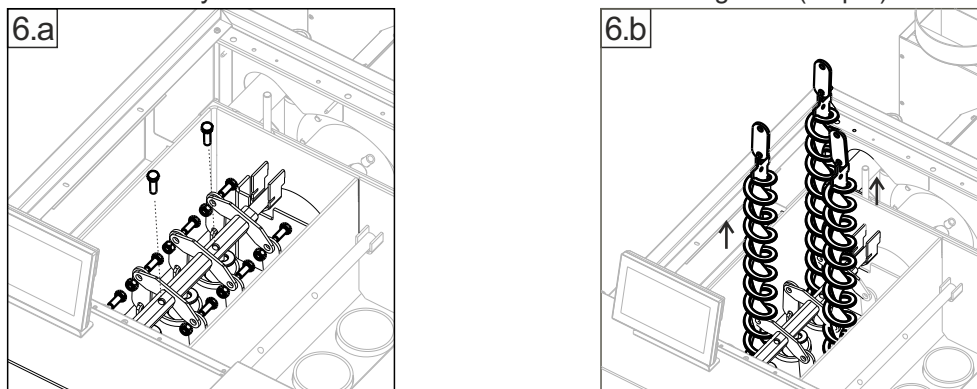

Switch the boiler off and disconnect it from electric power.

1 - Remove the casing cover.

2 - Unscrew the 4 screws and remove the flue ducts door.

3,4 - Unscrew the 2 screws and lift turbulators (first pass) with bracket as shown in picture.

5 - Unscrew the 2 screws from carrier on second pass.

6 - Remove all turbulators with carrier. (If you can't remove all turbulators together, then unscrew all screws on all turbulators (6.a) and remove turbulators one by one (6b)).

NOTE:

Place turbulators back in the same way but in the reverse order!

There are 1 or 2 sets of turbulators (depending on the model of boiler)

PROTECTIVE GLOVES ARE OBLIGATORY!



**7.2. REPLACEMENT OF THE EL. HEATER WITH NEW EL. HEATER
DIAMETER Ø20 mm**



Electric heater with a diameter of Ø 20 mm

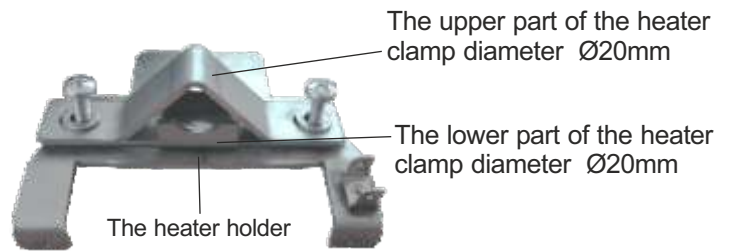

The heater holder with clamp for electric heater with a diameter of Ø 20 mm

1. Unplug the safety pressure switch tube (detail A), and disconnect the wires of the electric heater from the terminal block (Detail B).

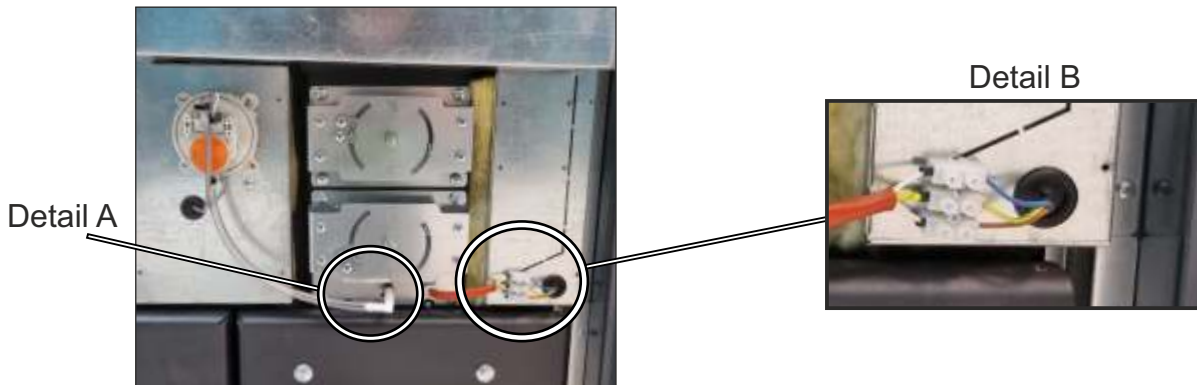

2. Unscrew the 4 screws and remove the primary air regulation. Then unscrew the 2 heater holder screw and pull out heaters holder together with the el. heater.

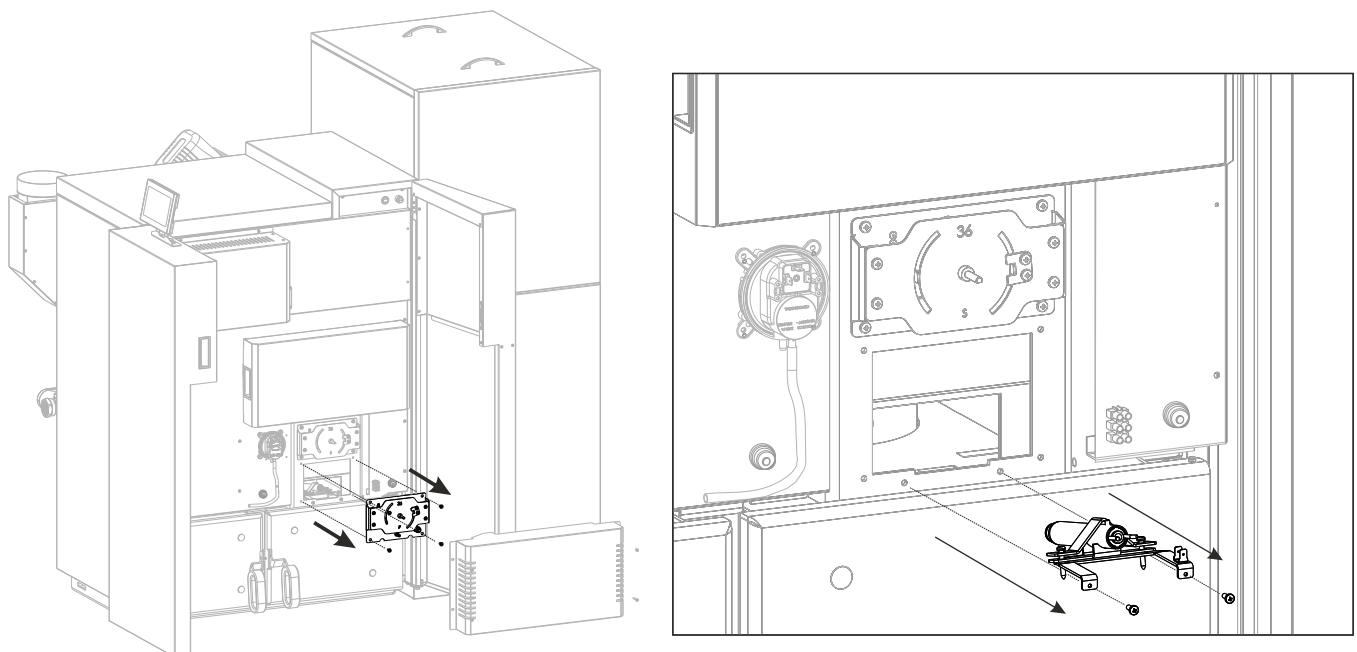

Replacement of the electric heater

3. Unscrew the two screws and remove the heater clamp. Insert the new el. heater, turn it so that the shafts at the front part of the el heater are turned vertically (see detail C) and gently attach it to the heater holder (Still not fully tightened).

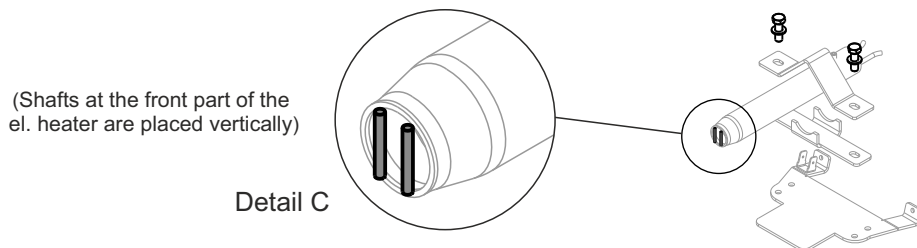

4. Place the el. heater with the holder in place and fasten it with two screws. Set the heater to the inner edge of the burner hole (see detail D). If necessary, loosen the clamp of the heater holder and push the holder until the edge of the burner hole and then tighten the clamp. Place the primary air regulation and connect with 4 screws. Connect the el. heater wires to the terminal block (detail B) and connect pressure switch tube (detail A).

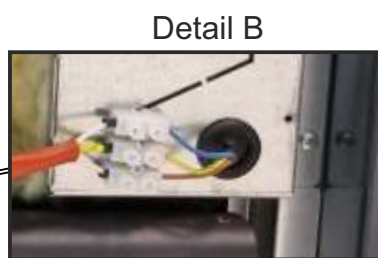
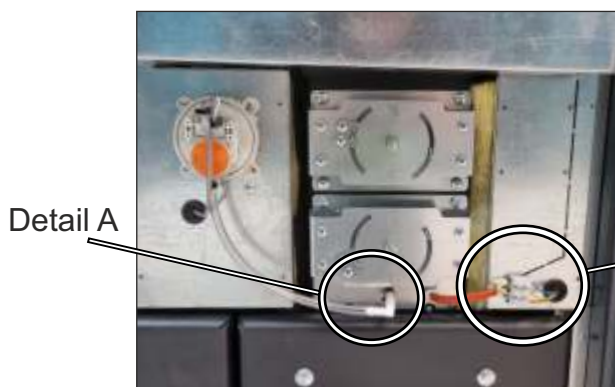
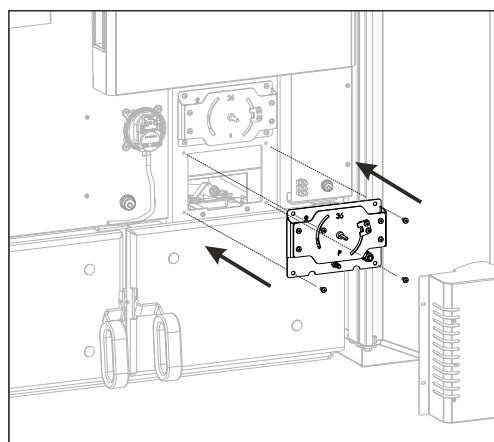
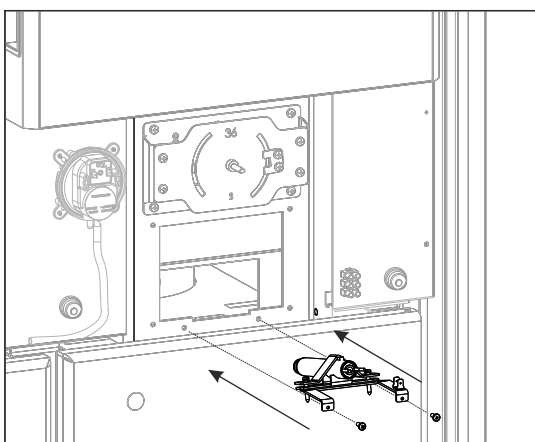

Detail D

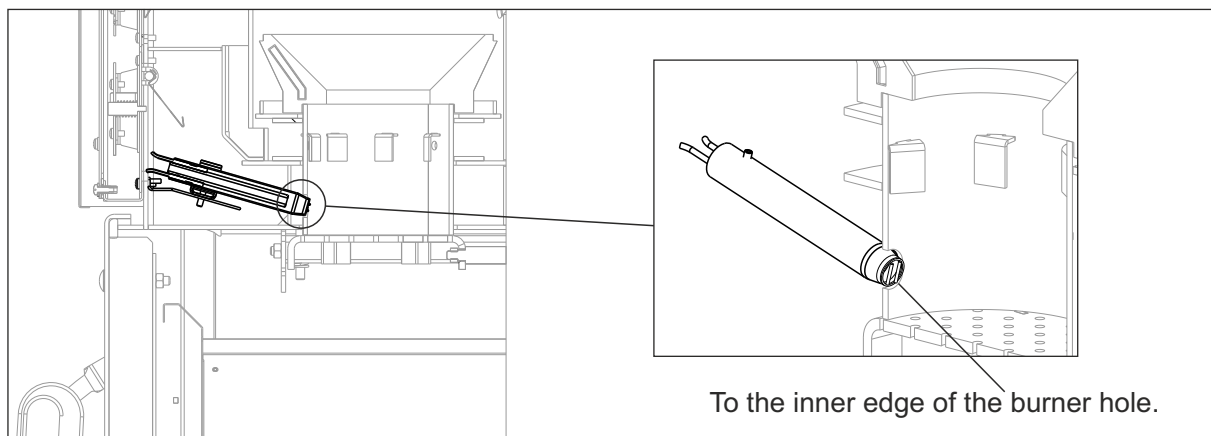

7.3. CLEANING OF PELLETTANK AND SCREW FEEDER (TRANSPORTER)



Cleaning the pellet tank from dust is must be done as needed or at least once a year. Protective gloves are obligatory!

The procedure for cleaning the tank and screw feeder for PelTec II Lambda 24-48 (for PelTec II Lambda 12-18 the same cleaning principle is used, only the controller box is in a different place):

- Switch off the boiler and remove the plug from the socket.

1. Remove the front lower cover of the tank (1a).
2. Remove the cover and protective grate (2a) and the front upper cover of the tank (2b).
3. If you use a vacuum cleaner, clean the inside of the tank to make it easier to remove the screw feeder.
4. Disconnect the screw feeder connector (4a) from the controller box and remove the screw feeder cable from the plastic clip on the back side of the boiler cover (4b).
5. Remove flexible PVC tube (5a).
6. Release and remove the bracket (6a) witch holding the screw feeder.
- 7_1. Remove the pellet screw feeder (7a) and clean it of pellets and dust (shake it out).
- 7_2. If the space does not allow removing the screw feeder (7a):
 - disconnect the connector of the pellet level sensor (7b) from the controller box (on the PelTec II Lambda 12/18 boiler, pay attention to this cable of the pellet level sensor so that it is not damaged after disconnection, as it remains free for a large length and can fall to the floor).
 - Unscrew the two screws (7c) that hold (keep) the tank and the boiler together.
 - Move the tank (7d) away from the boiler enough to allow the screw feeder (7b) to be removed.
8. If you use a vacuum cleaner, clean the screw feeder support (8a) of pellets and dust.
9. If you did not use a vacuum cleaner, remove the screw feeder support (9a) and clean the tank of pellets and dust through the hole (9b).
10. Return all parts to their place (in the state before the start of the cleaning process), but in the reverse order.

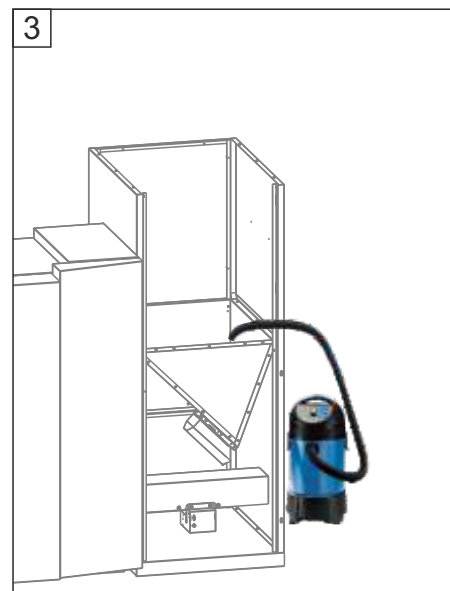
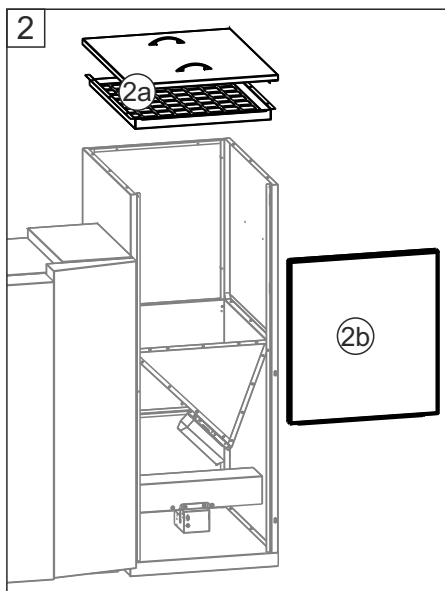
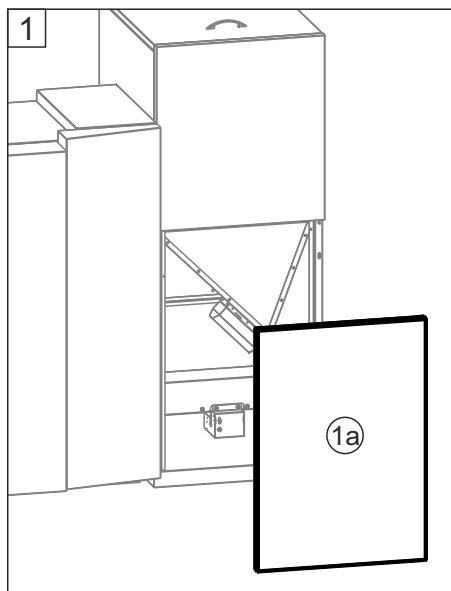

Cleaning of pellet tank and screw feeder (transporter)

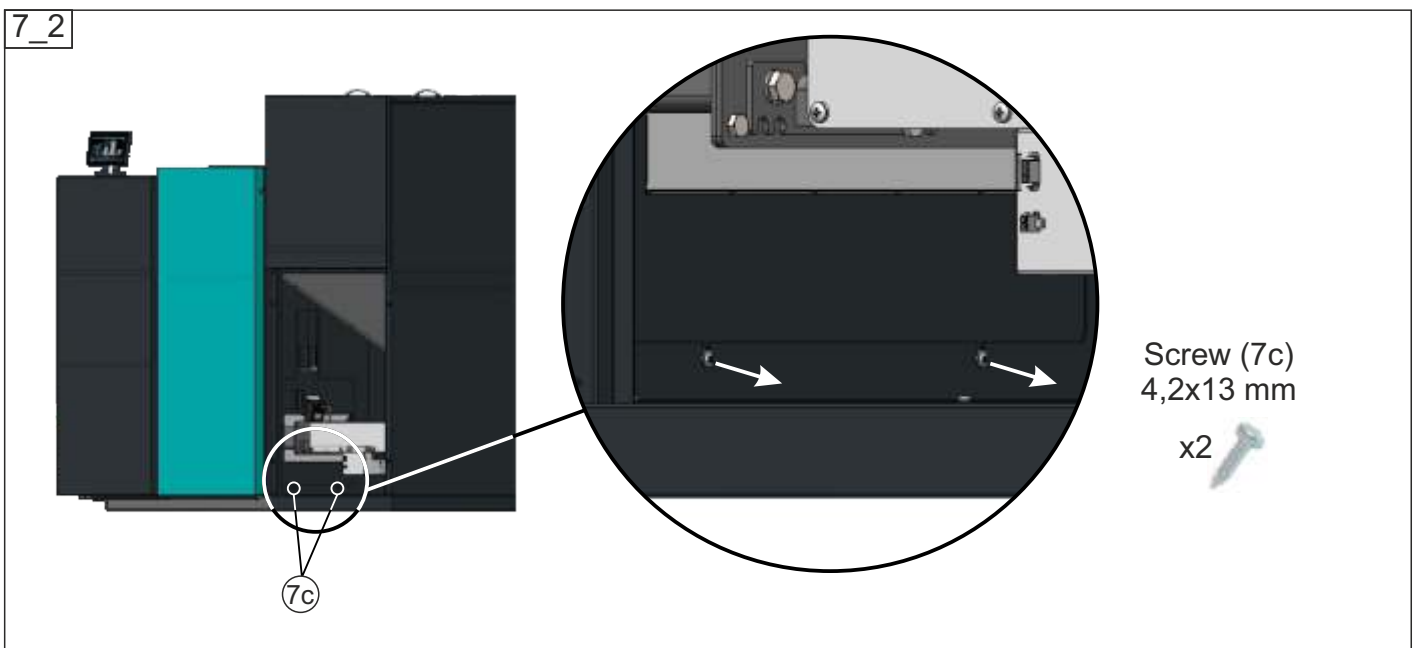
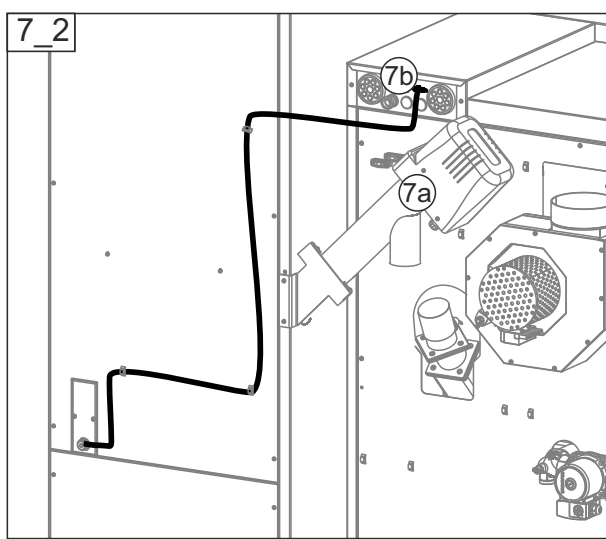
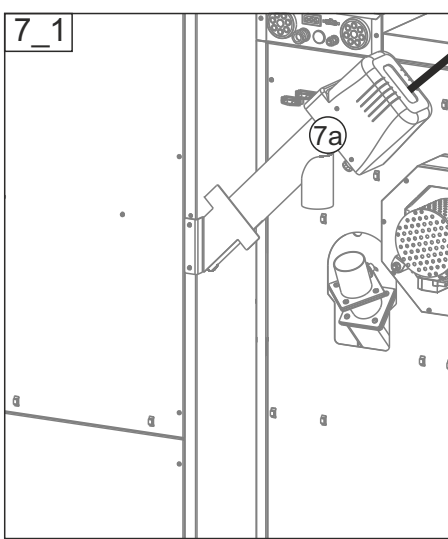
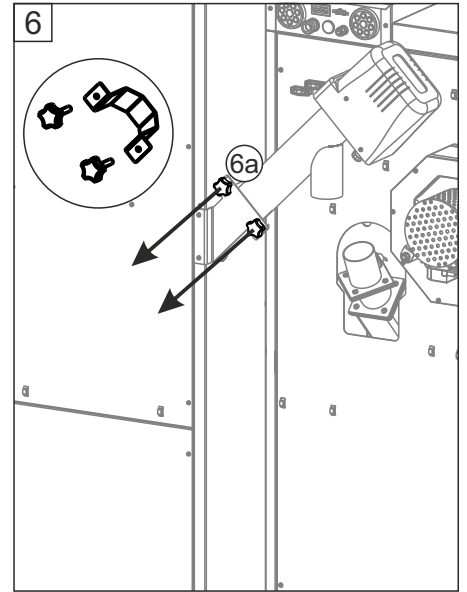
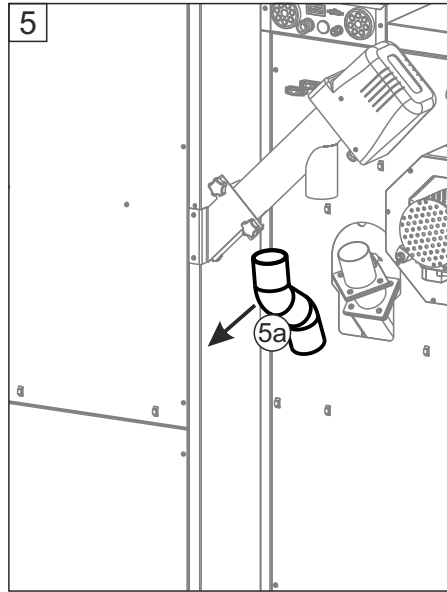
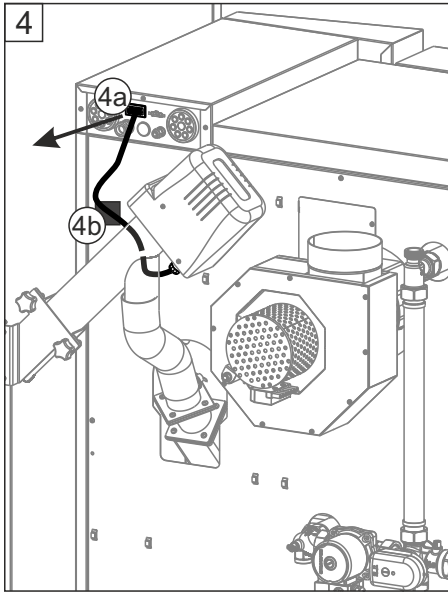

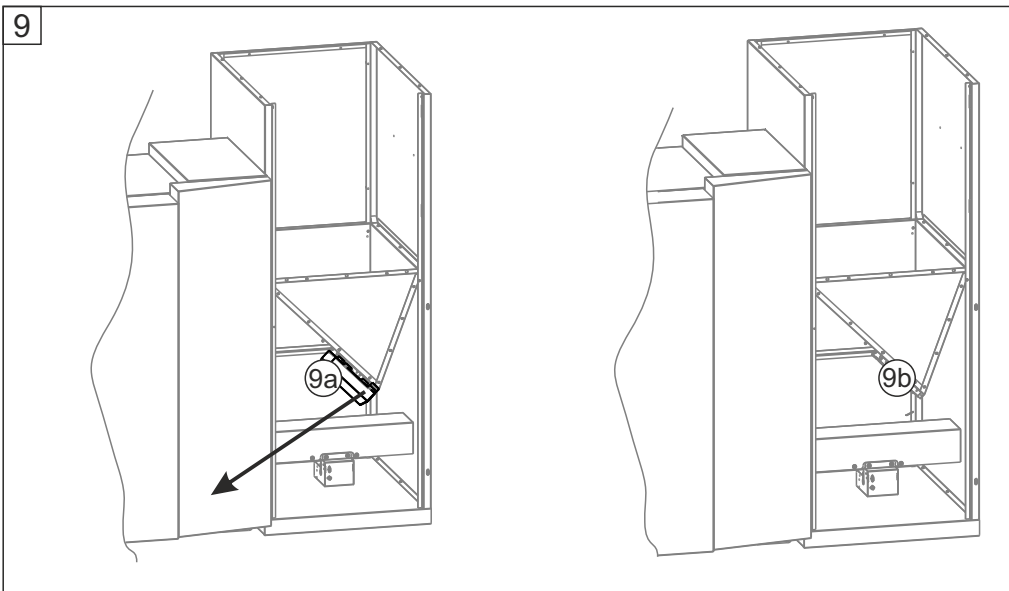
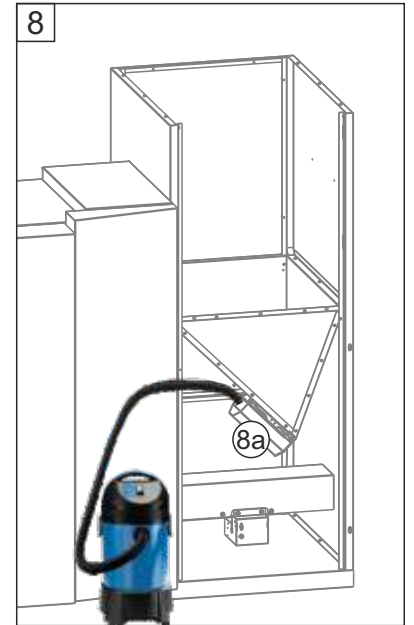
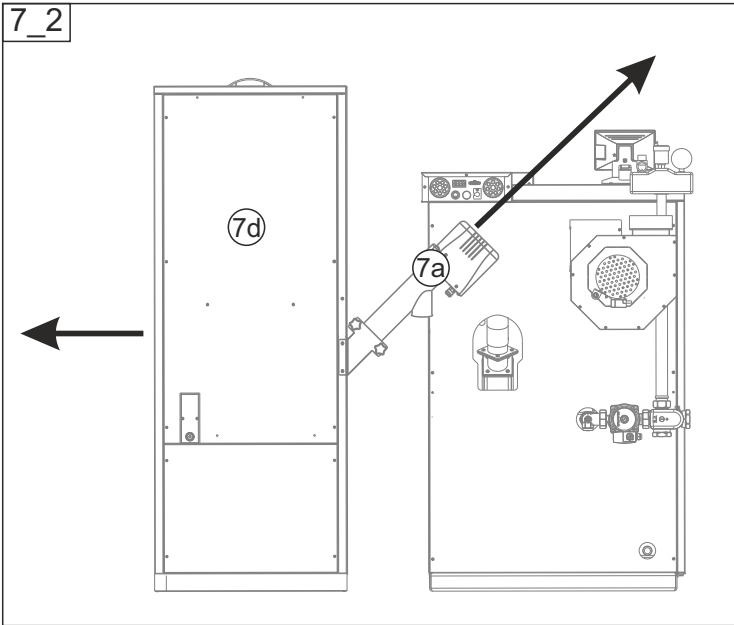

8.0. CIRCULATOR PUMP INSTALLATION

8.1. GRUNDFOS UPM3 HYBRID (25-70) (can be installed to PeITec II Lambda)

8.1.1. USER INTERFACE

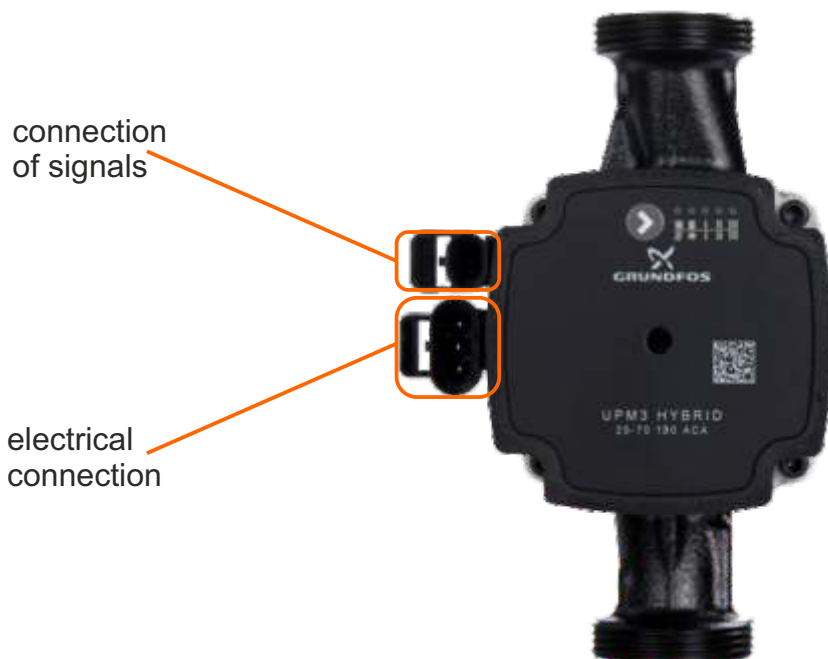

The user interface is designed with a single push button, one red/green LED, one green and three yellow LEDs.

User interface with one button and five LEDs.

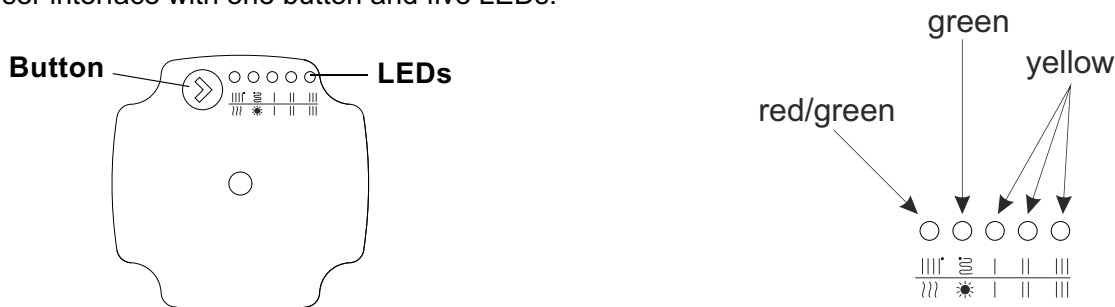

The user interface shows:

- operation status
- alarm status/errors

UPM3 HYBRID

Circulator pump is either for external PWM signal control with profile A or C (is used here), or for internal control of two operating modes with $AUTO_{ADAPT.}$ (not used here)

8.1.2. POSSIBILITY OF ADJUSTING THE PUMP (it is recommended that the pump be operated at factory settings)

Controlling the user interface (setting the pump) is possible by pressing a button and following the display on the LED interface. The user interface displays the schedule by turning on/blinking/turning off each LED as shown in the tables below. The currently selected setting is always displayed on the interface, which can be changed with each button press.

12 blinks per second

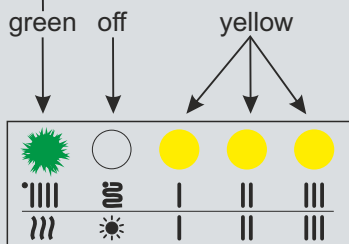

FACTORY SETTING
(PWM A curve 3 signal on)

LED BLINKING	
	1 BLINK PER SECOND
	12 BLINKS PER SECOND

NOT IN USE

Control mode	LED1 green	LED2 green	LED3 yellow	LED4 yellow	LED5 yellow
PP AA	●	○	○	○	○
CP AA	○	●	○	○	○
PP1	●	○	●	○	○
PP2	●	○	●	●	○
PP3	●	○	●	●	●
CP1	○	●	●	○	○
CP2	○	●	●	●	○
CP3	○	●	●	●	●
CC1	○	○	●	○	○
CC2	○	○	●	●	○
CC3	○	○	●	●	●
PWM C signal off	○	☒ ¹	●	●	●
PWM C signal on	○	☀ ²	●	●	●
PWM A curve 1 signal off	☒ ¹	○	●	○	○
PWM A curve 1 signal on	☀ ²	○	●	○	○
PWM A curve 2 signal off	☒ ¹	○	●	●	○
PWM A curve 2 signal on	☀ ²	○	●	●	○
PWM A curve 3 signal off	☒ ¹	○	●	●	●
PWM A curve 3 signal on	☀ ²	○	●	●	●

FACTORY SETTING

☒¹ 1 blink per second
☀² 12 blinks per second

Note: Each time you press the button the pump setting changes.

8.1.3. ALARM STATUS/ERRORS

If the pump detects one of the alarms, the 2-color LED 1 changes color from green to red. When is it alarm active, LEDs show the type of alarm according to the table below. If several alarms are active at the same time, the LEDs show only the highest priority alarm. Priorities are determined according to the schedule in table. If there is no active alarm, the operating mode is displayed.

Pump screen	Meaning	Pump operation	Counter action
1 red LED + 1 yellow LED (LED 5)	Rotor is blocked.	Try to operate again.	Wait or unblock the shaft.
1 red LED + 1 yellow LED (LED 4)	Supply voltage is too low.	Only warning, pump runs.	Check supply voltage.
1 red LED + 1 yellow LED (LED 3)	Electrical failure.	Pump is stopped because supply voltage is too low or serious failure has occurred.	Check supply voltage / replace the pump.

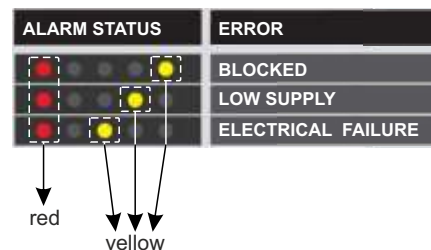

8.1.4. GRUNDFOS UPM3 ANTI BLOCKING CONCEPT

UPM3 has a double safety de-blocking system:

- deblocking software

Continuous restart after 1,33 seconds with a maximum torque of 24.8 Ncm.

- deblocking device

Manual deblocking device, accessible from front side without demounting the controller box.

Deblocking device

Deblocking device consists of an axially movable plunger secured with an O-ring and a retracted spring inside a stainless steel housing that is welded to the rotor. It is made for pumps integrated into the device so that the pump can be accessed from the front without demounting the controller box. By pushing and turning the screwdriver, the plunger pushes the shaft axially into the pump until it can rotate. The force is sufficient to unblock the pump where limescale has accumulated, for example if the device was tested wet and stored for a long time. Before, during and after unblocking, the device must tight and must not leak water.

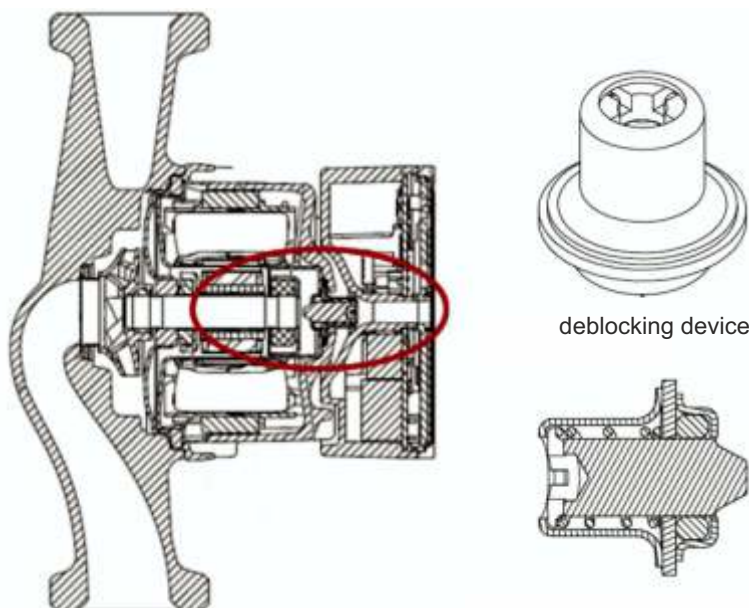

sectional drawing of deblocking device

Pump is blocked

If the pump or system is filled with water for the first time and the pump is stopped for a longer period (several weeks or months), it might happen that the pump is not able to start. The pump tries to start with a cycle every 1.33 seconds and the display shows LED 1 = red and LED 5 = yellow.

In this case, please use a screwdriver and put it in the hole in the middle of the front plate. Push it towards the pump and move it counter clockwise. Probability, the pump will start.



Note:

In some cases pump cannot be unblocked with screwdriver. If this happens pump must be disassembled and rotor blades must be turned (unblocked) by hand.

Error finding

ERROR	SCREEN	SOLUTION

Warning: Before starting any work at the pump, switch off the power supply. Make sure that the power supply cannot be switched on accidentally.

Warning:

This appliance can be used by children over 8 years old and persons with reduced physical, sensory or mental capabilities or lack of experience and knowledge if they are under supervision or if they are given instruction concerning use of the appliance in a safe way and if they understand the involved hazards. Children must not play with the appliance. Children must not clean or maintain the device without supervision.

9.0. CHANGING THE BOILER CONTROL UNIT SCREEN BATTERY (CR 1632)

If there is a significant clock delay or the clock settings are automatically set to 00:00 and the date to 1.1.2020. (after turning OFF/ON the main switch of the boiler or after a power failure) it is necessary to replace the battery located on the bottom side of the screen (battery type CR 1632). The battery needs to be replaced even if the warning W 9 or error E 48 appears. The clock can be wrong, the delay can be 2-3 minutes per month which is considered normal, we recommend that you adjust it periodically. How to adjust the clock is described in the technical instructions for controller_book_2/2.

The battery is located on the bottom side of the screen (1). First, use a small thing to pull out the plastic box battery (2), which has two polarities (3). Replace the battery and make sure it is turned the right way (4). Place the battery in the plastic box (5) and insert it to the end of the slot so that it is in its original position, aligned with the metal part (6).



CORRECT DISPOSAL OF THIS PRODUCT

Your boiler is marked in accordance with Directives: 2006/42/EC, 2014/30/EU, 2014/35/EU and contains electrical components.

According to EU Regulation 2015/1189 implementing Directive 2009/125/EC with regard to Eco-Design requirements for solid fuel boilers, we draw your attention to the following:

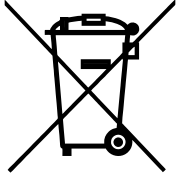

MARK FOR MARKING SEPARATE EE WASTE COLLECTION



This marking on the product indicates that the product contains electrical and electronic parts and must be disposed of separately, it must not be mixed with other waste. Your boiler is labeled in accordance with the Waste Electrical and Electronic Equipment Regulation (WEEE) and can be returned through the return and collection system available to you.

Household users should contact the retailer from whom they purchased this product, their local distributor, or their state agency for details on where and how to dispose of this product. Business users should contact their supplier and review the terms of the sales contract or contact a government agency for details on where and how to dispose of this product.

Naziv dobavljača / Ime dobavitelja / Supplier name / Name des Lieferanten / Le nom du fournisseur ou la marque commerciale / De naam van de leverancier / Piegādātāja nosaukums A šāllītō nevēt / Szállító neve / Název dodavatel / Meno dodávateľa / Nome del fornitore / Navn på leverandøren:		PeITec II Lambda			
Dobavljačeva identifikacijska oznaka modela / Modellkennung des Lieferanten / La référence du modèle donnée par le fournisseur / De typeaanduiding van het model van de leverancier / Piegādātāja modeļa identifikators / A šāllītō āital megadott modellazonosítót / Identifikačni značka modelu používanā dodavatel / Identifikačný kód modelu dodávateľa / Codice identificativo del modello del fornitore / Leverandørmodellens id-mærke:	12	18	24	36	48
Razred energetske učinkovitosti / Razred energetske učinkovitosti / Energy efficiency class / Energieeffizienzklasse / La classe d'efficacité énergétique du modèle / De energie-efficiëntieklasse van het model / Modelja energoefektivitātes klase / Energiatékonyági osztályát / Trīda energetickē učinkosti / Trīda energetickē učinkosti / Clasi di efficienza energetica / Energieeffektivitetsklasse:	A+	A+	A+	A+	A+
Nazivna toplinska snaga / Nazivna izhodna moč / Rated heat output / Nennwärmeleistung / La puissance thermique directe / De nominale warmteafgifte / Izteikta nominālā siltuma jauda / Mērt hōiteljēstīmēny / Jmenovitý tepelný výkon / Mēnovitý tepelný výkon / Potenza termica nominale / Nominel varmeydelse:	12	18	24	36	48
Indeks energetske učinkovitosti / Indeks energetske učinkovitosti / Energy efficiency index / Energieeffizienzindex / L'indice d'efficacité énergétique / De energie-efficiëntie-index / Energieeffektivitātes indekss / Enerģiatékonyági mutató / Index energetickē učinkosti / Index energetickē učinkosti / Indice di efficienza energetica / Energieeffektivitetsindeks:	116	119	121	121	122
Sezonska energetska učinkovitost grijanja prostora / Sezonska energetska učinkovitost pri ogrevanju prostorov / Seasonal space heating energy efficiency / Raumheizungs-Jahresnutzungsgrad / L'efficacité énergétique saisonnière pour le chauffage des locaux ηS / De seizoensoegebonden energie-efficiëntie voor ruimteverwarming / Telpu apsīlides sezonas energoefektivitāte / Sezonālis heļisīgūtēsi hatāsfok / Sezonnī enerģētiskā učinkost vītāpēni / Sezōna enerģētiskā učinkost vīkurovania priestoru / Efficienza energetica stagionale del riscaldamento d'ambiente / Sæsonmæssig energieeffektivitet ved rumopvarmning:	79	80	82	83	83

- Poštivajte upozorenja i smjernice za ugradnju i periodično održavanje navedene u poglavljima ovog priručnika s uputama.

- Upoštevacite upozorila in navodila za namestitvev in redno vzdrževanje, navedena v poglavjih priručnika z navodili.

Varnostni ukrepi, ki se sprejmejo pri sestavljanju, montaži ali vzdrževanju kotla:

Kotel ne sme delovati v vnetljivi in eksplozivni atmosferi.

Pred kakršnim koli posegom na napravi mora biti izklopljeno vse električno napajanje.

- Comply with the warnings and instructions concerning installation and routine maintenance provided in the instruction manual.

- Beachten Sie die Warnungen und Hinweise betreffend die Installation und regelmäßige Wartung in den Kapiteln der Bedienungsanleitung.

- Respecter les avertissements et les indications sur l'installation et l'entretien périodique fournis dans les chapitres du manuel d'instructions.

- Neem de waarschuwingen en instructies voor installatie en periodiek onderhoud in acht zoals aangegeven in de hoofdstukken van de gebruiksaanwijzing.

- Kõvesse a használati útmutató, fejezetében közölt Wgyelmezéteéseket, beépítési utasításokat és az időszakos karbantartásra vonatkozó előírásait.

- Dodržujte varování a pokyny pro instalaci a pravidelnou údržbu, které jsou popsány v kapitolách návodu k obsluze.

- Dodržujte varovania a pokyny pre inštaláciu a pravidelnú údržbu, ktoré sú opísané v dodanom návode na obsluhu.

- Seguire le avvertenze e le linee guida per l'installazione e la manutenzione periodica elencate nelle sezioni di istruzioni.

- Følg advarstler og retningslinjer for installation og periodisk vedligeholdelse, der er anført i afsnittene i denne brugsanvisning.

Centrometal

HEATING TECHNIQUE



Company assumes no responsibility for possible inaccuracies in this book originated typographical errors or rewriting, all the pictures and diagrams are principal and it is necessary to adjust each actual situation on the field, in any case the company reserves the right to enter their own products such modifications as considered necessary.

Centrometal d.o.o. Glavna 12, 40306 Macinec, Croatia

central tel: +385 40 372 600, fax: +385 40 372 611
service tel: +385 40 372 622, fax: +385 40 372 621

www.centrometal.hr
e-mail: servis@centrometal.hr